

SPECIFY CATALOG NO. AND SERIAL NO. WHEN ORDERING PARTS		REVISED BULLETIN	DATE
<b>CHARGER - ALBION</b>		54-04-0377	Jan. 2005
CATALOG NUMBER	<b>860-48-59-6561</b>	SERIAL NUMBER	<b>411E</b>
WIRING INSTRUCTION			

00  
0

**EXAMPLE:**  
Component Parts (Small #)  
Are Included When Ordering  
The Assembly (Large #).

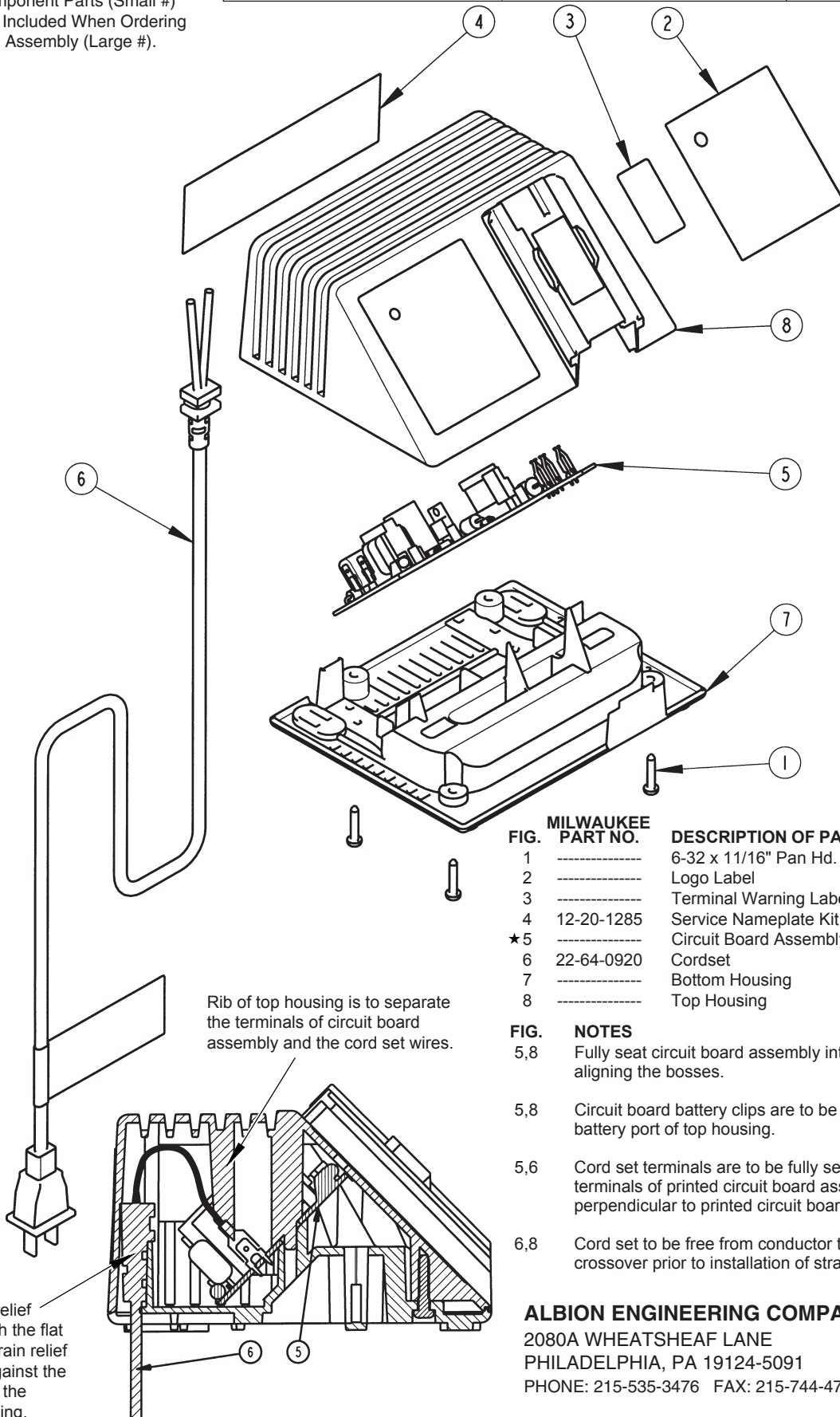

FIG.	MILWAUKEE PART NO.	DESCRIPTION OF PART	NO. REQ.
1	-----	6-32 x 11/16" Pan Hd. Slit. PT T-10	(4)
2	-----	Logo Label	(1)
3	-----	Terminal Warning Label	(1)
4	12-20-1285	Service Nameplate Kit	(1)
★5	-----	Circuit Board Assembly	(1)
6	22-64-0920	Cordset	(1)
7	-----	Bottom Housing	(1)
8	-----	Top Housing	(1)

- FIG. NOTES**
- 5,8 Fully seat circuit board assembly into top housing, aligning the bosses.
  - 5,8 Circuit board battery clips are to be fully inserted into battery port of top housing.
  - 5,6 Cord set terminals are to be fully seated on mating terminals of printed circuit board assembly and perpendicular to printed circuit board surface.
  - 6,8 Cord set to be free from conductor twists and cord crossover prior to installation of strain relief into top housing.

**ALBION ENGINEERING COMPANY**  
2080A WHEATSHEAF LANE  
PHILADELPHIA, PA 19124-5091  
PHONE: 215-535-3476 FAX: 215-744-4719 www.albioneng.com