



SERVICE PARTS LIST

BULLETIN NO.
54-04-0120

SPECIFY CATALOG NO. AND SERIAL NO. WHEN ORDERING PARTS		REVISED BULLETIN	DATE
7.2 VOLT BATTERY CHARGER			Feb.'89
CATALOG NO. 48-59-0210	DATE CODE	WIRING INSTRUCTION	
	ECIJ09A	See Reverse Side	

EXAMPLE:

00	0
----	---

 Component Parts (Small #) Are Included
 When Ordering The Assembly (Large #).

FIG.	PART NO.	DESCRIPTION OF PART	NO. REQ.
1	06-82-7409	8-16 x 1/2" Pan Hd. Plastite Torx	(4)
2	22-64-0025	Cord Set (See Note)	(1)
3	31-50-0780	Top Housing	(1)
4	31-50-0790	Bottom Housing	(1)
5	-----	Circuit Board	(1)
6	-----	Transformer	(1)
7	23-74-0890	Terminal	(2)
	12-99-0760	Service Nameplate	(1)

NOTE
 Cord Set requires terminals No. 23-74-0890 —
 Sold separately.

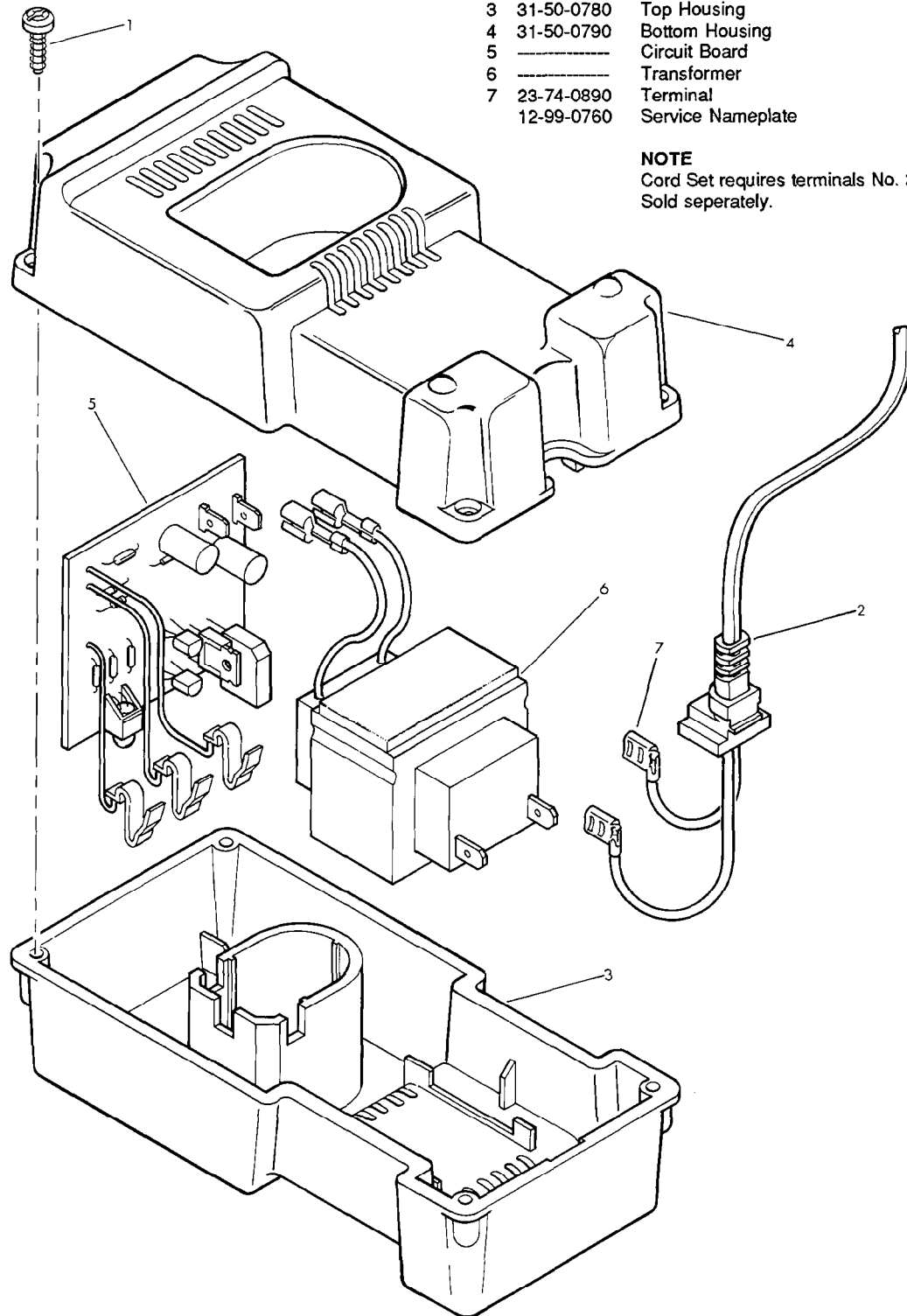

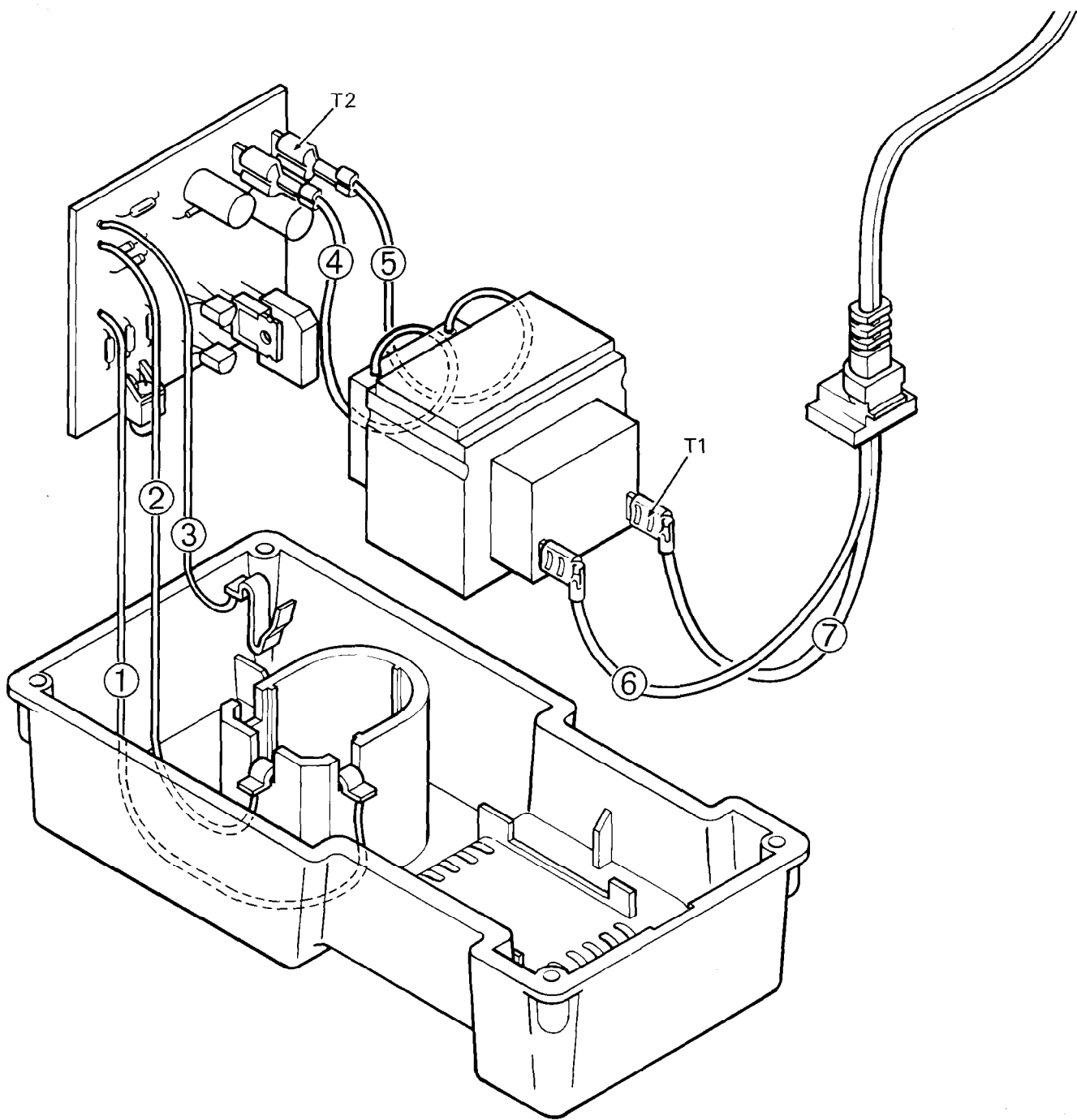

WIRING SPECIFICATIONS

Wire No.	Wire Color	Origin or Gauge	Length	Terminals, Connectors and 1 or 2 End Wire Preparation
1	Red	22 Ga.	4"	Component of circuit board assembly.
2	Red	22 Ga.	3"	Component of circuit board assembly.
3	Red	22 Ga.	2-1/2"	Component of circuit board assembly.
4	Yellow	18 Ga.	5-1/4"	Strip 1/4" for T2.
5	Yellow	18 Ga.	5-1/4"	Strip 1/4" for T2.
6	Black	18 Ga.	1-1/2"	Strip 3/16" for T1.
7	Black	18 Ga.	3"	Strip 3/16" for T1.

NOTE:
 All leads must be held to $\pm 1/8"$.
 All field leads to be measured from and perpendicular to laminations.
 All lead lengths are before stripping.

TERMINAL DESCRIPTION		
Code	Part No.	Qty.
T1	23-74-0890	2
T2	23-74-0440	2
CONNECTOR DESCRIPTION		