

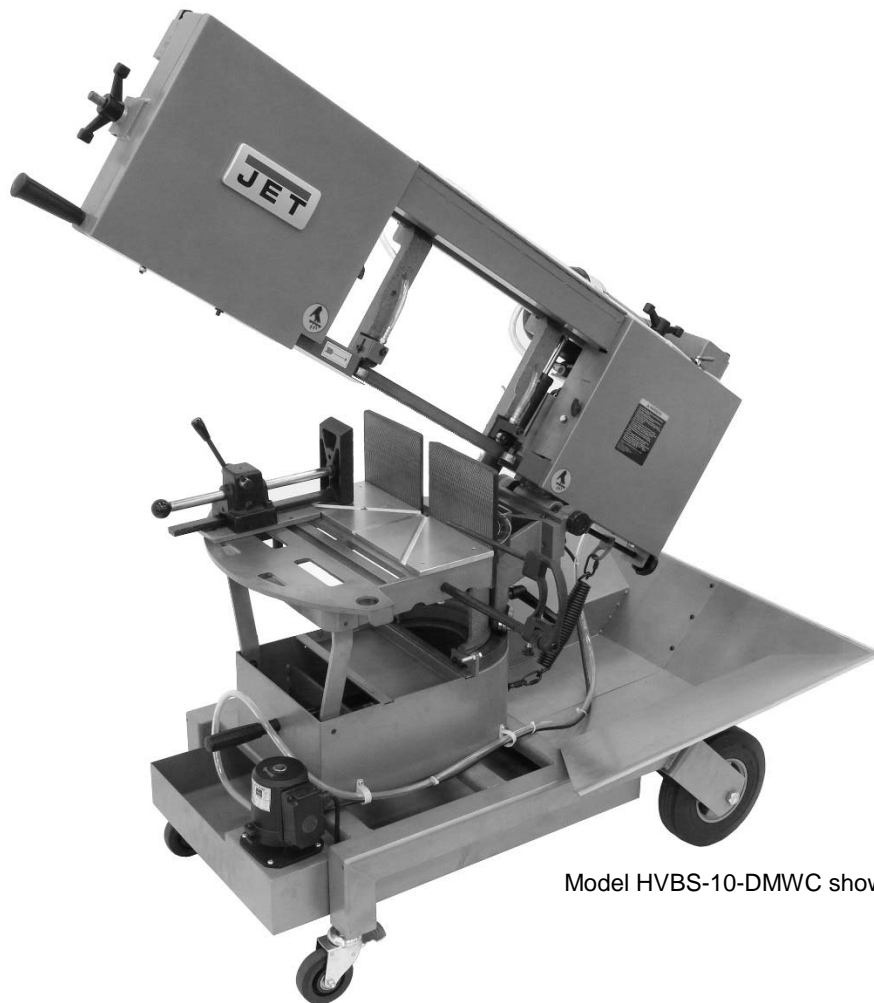

Operating Instructions and Parts Manual Portable Dual Mitering Band Saws

Models HVBS-8-DMW, HVBS-10-DMW, HVBS-10-DMWC



Model HVBS-10-DMWC shown

For HVS-8-DMW after serial no. 1701BG00017
For HVS-10-DMW after serial no. 1701BK00017

JET
427 New Sanford Road
LaVergne, Tennessee 37086
Ph.: 800-274-6848
www.jettools.com

Part No. M-424460
Edition 5 05/2017
Copyright © 2017 JET

11.2.1 HVBS-10-DMW/DMWC Bow Assembly – Exploded View

Figure 11-6

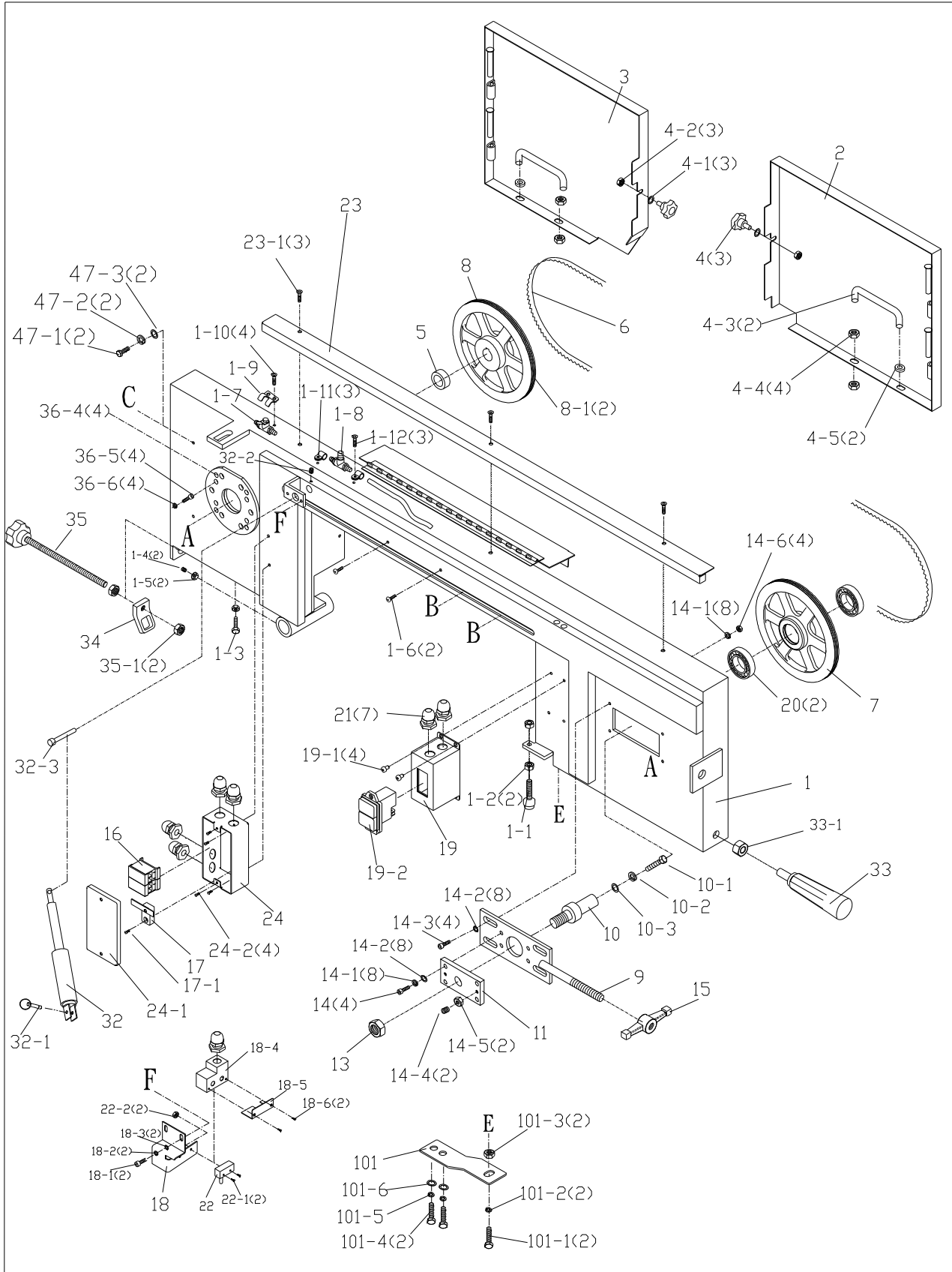

11.2.2 HVBS-10-DMW/DMWC Table Assembly – Exploded View

Figure 11-7

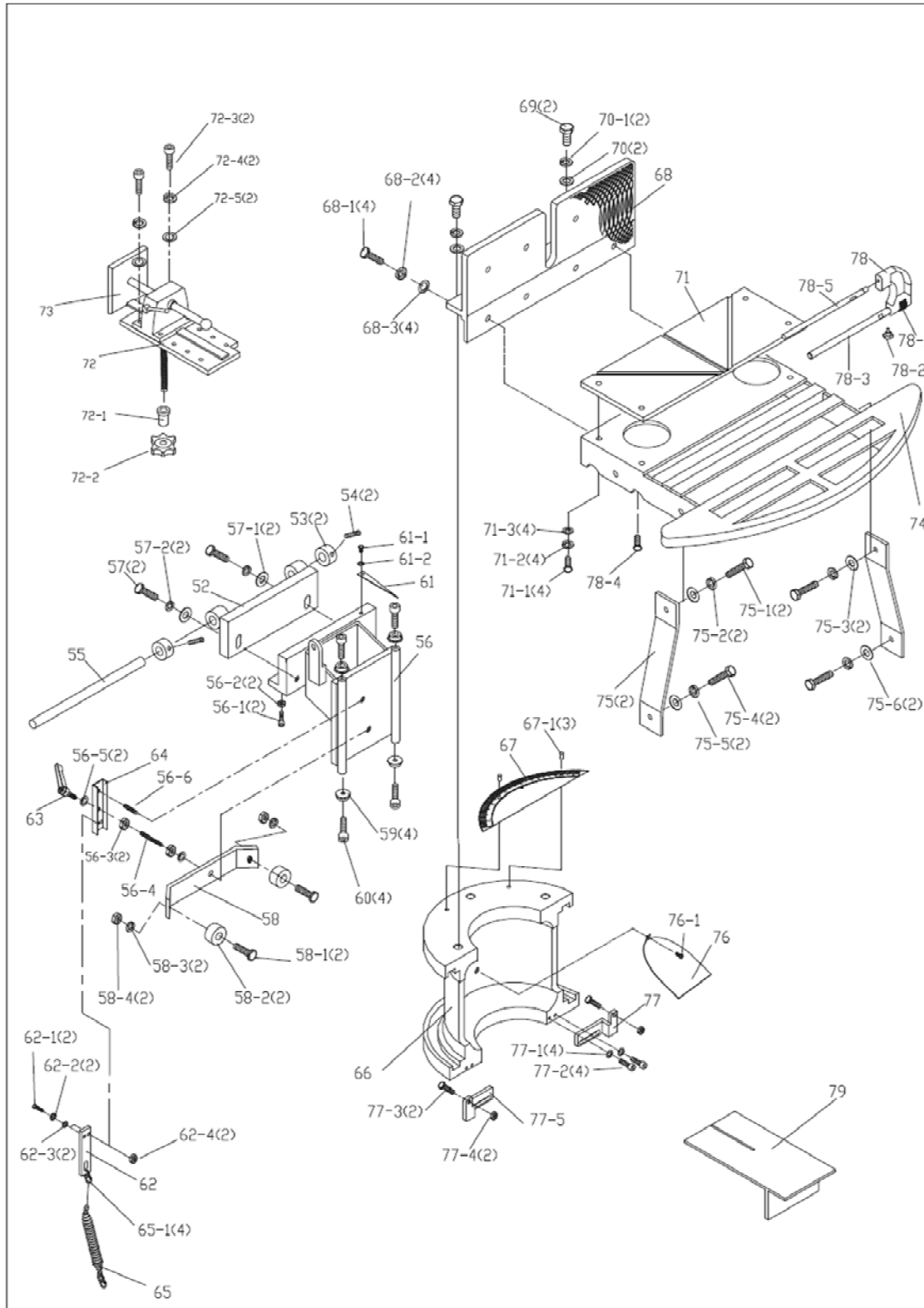

11.2.3 HVBS-10-DMW/DMWC Motor and Support Arm Assembly – Exploded View

Figure 11-8

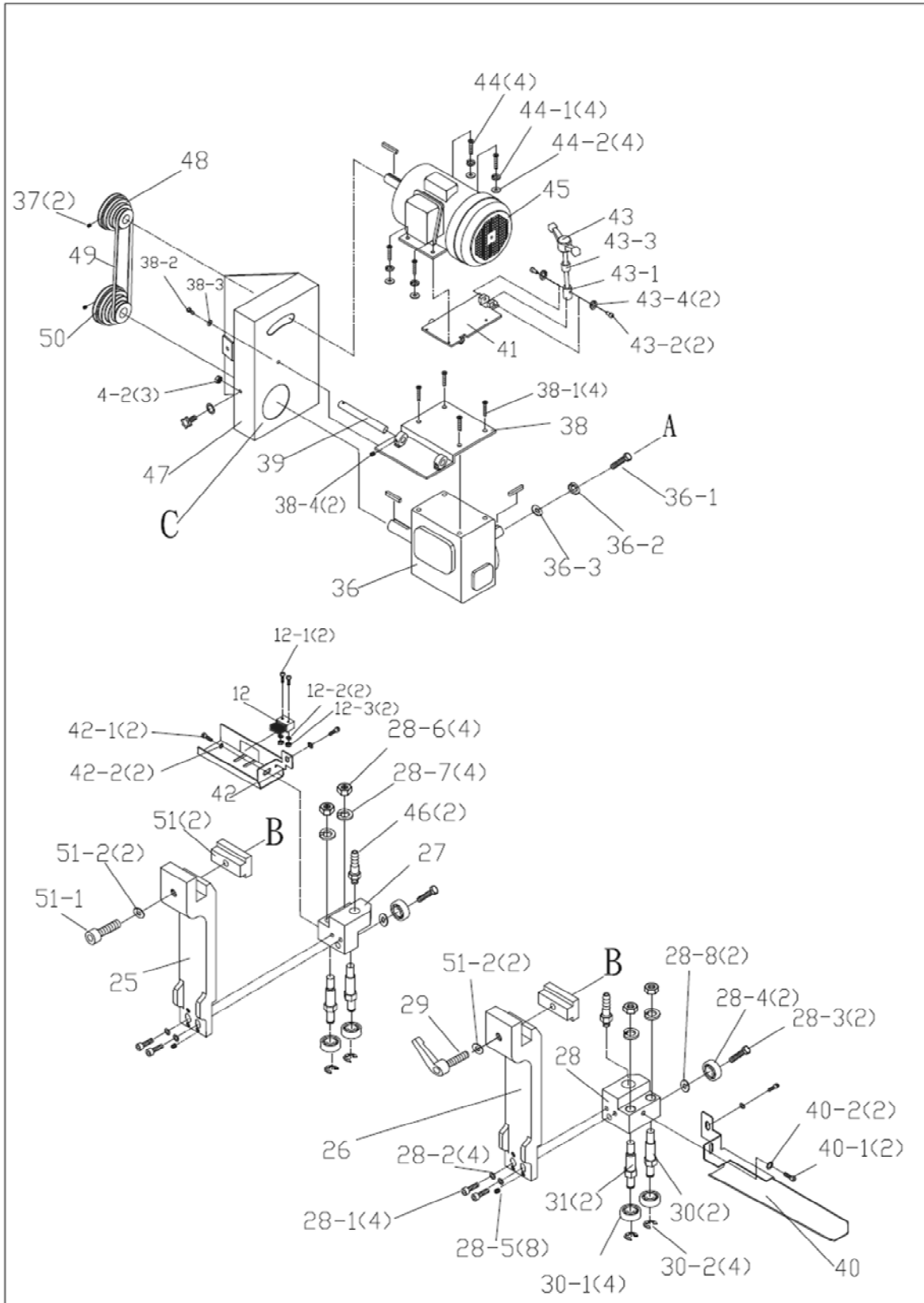

11.2.4 HVBS-10-DMW/DMWC Vise and Table Assembly – Exploded View

Figure 11-9

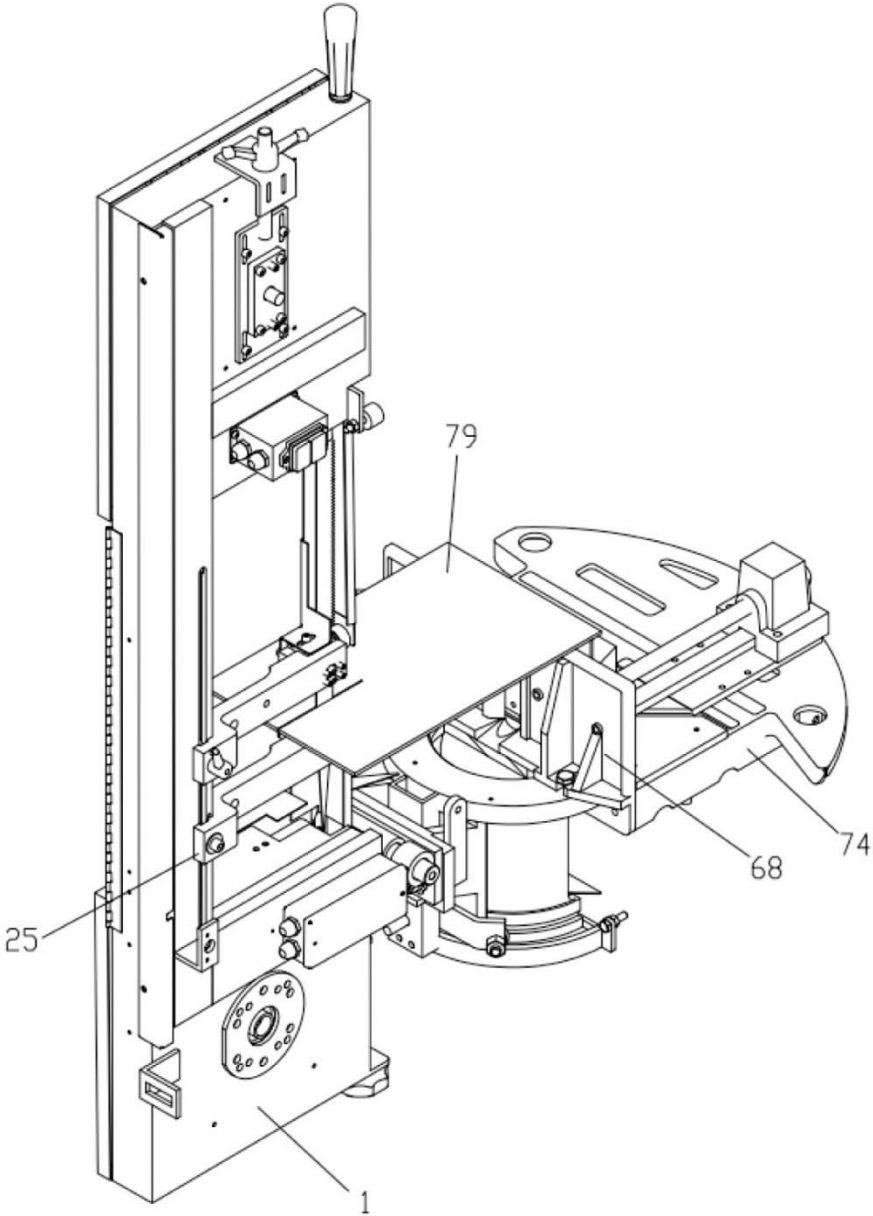

11.2.5 HVBS-10-DMW/DMWC Base Assembly – Exploded View

Figure 11-10

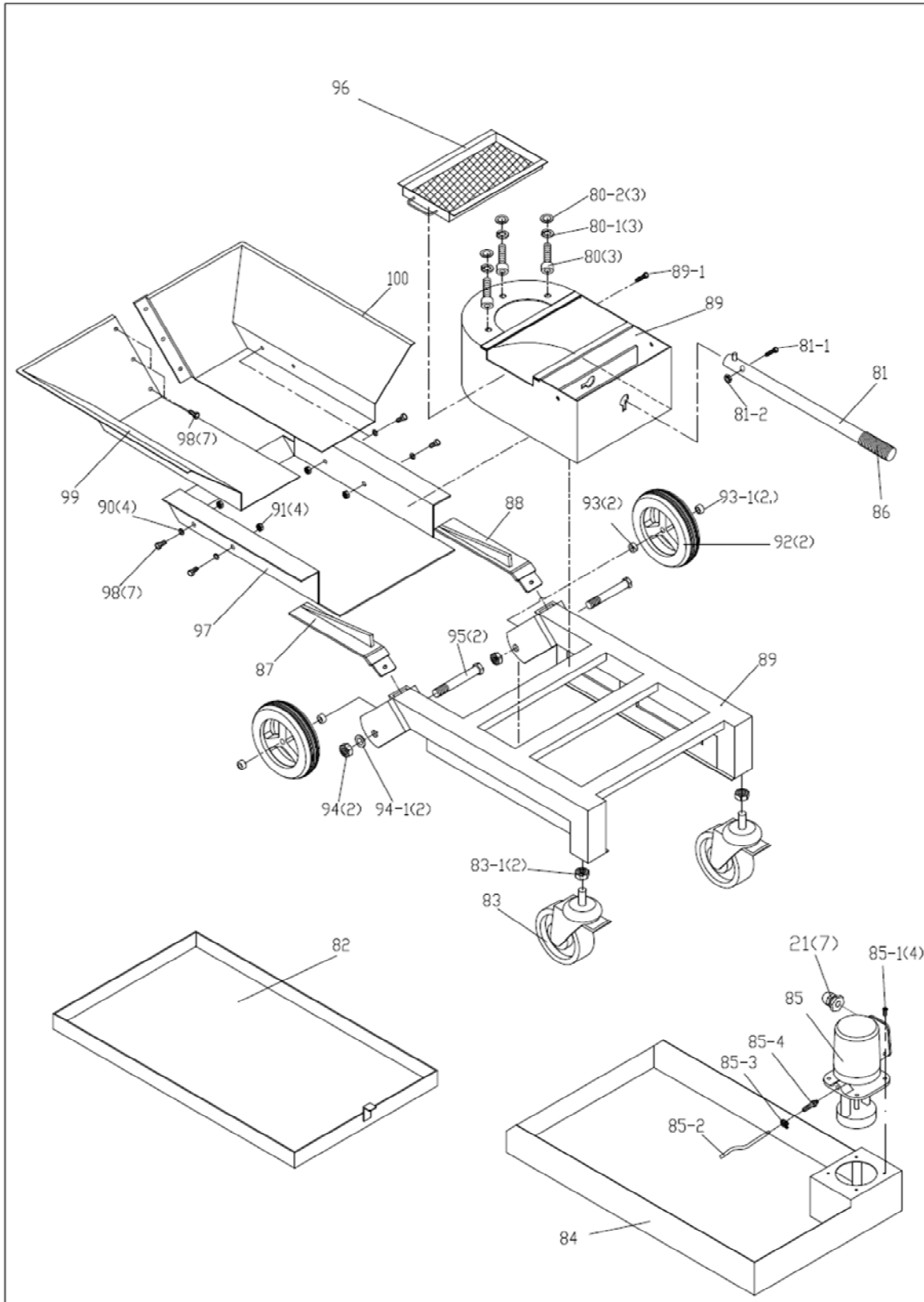

11.2.6 HVBS-10-DMW/DMWC – Parts List

Index No	Part No	Description	Size	Qty
1	HVBS-10-DMW-1	Saw Bow		1
1-1	HVBS-10-DMW-1-1	Stop Screw		1
1-2	TS-0570021	Hex Nut	5/16"-18NC	2
1-3	TS-1490081	Hex Cap Bolt	M8-1.25x45L	1
1-4	TS-1524051	Set Screw	M8-1.25x20L	2
1-5	TS-1540061	Hex Nut	M8-1.25	2
1-6	TS-2284082	Phillips Pan Hd Machine Screw	M4-0.7x8L	1
1-7	HVBS-10-DMW-1-7	Valve (copper)	5/16"	1
1-8	HVBS-10-DMW-1-8	Tee Fitting (copper)	5/16"	1
1-9	HVBS-10-DMW-1-9	Valve Holder		2
1-10	TS-1534032	Phillips Pan Hd Machine Screw	M6x10	1
1-11	HVBS-10-DMW-1-11	Hose Clamp		3
1-12	F001208	Phillips Pan Hd Machine Screw	M5x8	3
2	HVBS-10-DMW-2	Idler Wheel Guard		1
3	HVBS-10-DMW-3	Drive Wheel Guard		1
4	HVBS-10-DMW-4	Handle Screw	M6x5	3
4-1	TS-1550041	Flat Washer	6x13x1 mm	3
4-2	TS-2311061	Hex Nut	M6-1.0	3
4-3	HVBS-10-DMW-4-3	Guard Prop		2
4-4	TS-1540061	Hex Nut	M8-1.25	4
4-5	HVBS-8-DMW-13-1	Grommet		4
5	HVBS-10-DMW-5-1	Spacer		1
6	HVBS-10-DMW-6	Saw Blade	5/8T, 1 x 0.035 x 120"L (27x0.9x3048mm)	1
7	HVBS-10-DMW-7	Idler Wheel		1
8	HVBS-10-DMW-8	Drive Wheel		1
8-1	HVBS-10-DMW-8-2	Tire		2
9	HVBS-10-DMW-9	Tension Slider		1
10	HVBS-10-DMW-10	Idler Wheel Bearing		1
10-1	TS-1490031	Hex Cap Bolt	M8-1.25x20L	1
10-2	TS-2361081	Lock Washer	M8	1
10-3	TS-1550061	Flat Washer	8x25x2 mm	2
11	HVBS-10-DMW-11	Slider Cover		1
12	HVBS-8-DMW-43	Brush (square)		1
12-1	F001187	Phillips Pan Hd Machine Screw	M4x25	2
12-2	TS-1550021	Flat Washer	M4	2
12-3	TS-1540021	Hex Nut	M4	2
13	TS-2311161	Hex Nut	M16-2.0	1
14	TS-1482041	Hex Cap Bolt	M6-1.0x20L	4
14-1	TS-2361061	Lock Washer	M6	4
14-2	TS-1550041	Flat Washer	6x13x1 mm	8
14-3	TS-1482061	Hex Cap Bolt	M6-1.0x30L	4
14-4	TS-1524051	Set Screw	M8-1.25x20L	2
14-5	TS-2311081	Hex Nut	M8-1.25	2
14-6	TS-1540041	Hex Nut	M6-1.0	4
15	HVBS-10-DMW-15	Handle		1
16	HVBS-10-DMW-16	Terminal Block		2
17	HVBS-10-DMW-17	Cable Seat		1
17-1	TS-1533032	Phillips Pan Hd Machine Screw	M5-0.8x10	1
18	HVBS-10-DMW-18	Limit Switch Bracket		1
18-1	TS-1533032	Phillips Pan Hd Machine Screw	M5-0.8x10L	2
18-2	TS-2361051	Lock Washer	M5	2
18-3	TS-1550021	Flat Washer	4x10x1 mm	2
18-4	HVBS-10-DMW-18-4	Switch cover		1
18-5	HVBS-10-DMW-18-5	Cover		1
18-6	TS-2284082	Phillips Pan Hd Machine Screw	M4-0.7x8	2
19	HVBS-10-DMW-19	Switch Box		1
19-1	TS-2284082	Phillips Pan Hd Machine Screw	M4-0.7x8L	4
19-2	HVBS-10-DMW-19-2	Magnetic Switch		1
20	BB-6205ZZ	Bearing	6205ZZ	2
21	HVBS-10-DMW-21	Strain Relief	PG-9	7

Index No	Part No	Description	Size	Qty
22	HVBS-10-DMW-22	Limit Switch		1
22-1	F001187	Phillips Pan Hd Machine Screw	M4-0.7x25L	2
22-2	TS-1540021	Hex Nut	M4-0.7	2
23	HVBS-10-DMW-23	Upper Cable Cover		1
23-1	TS-1534032	Phillips Pan Hd Machine Screw	M6-1.0x10L	3
24	HVBS-10-DMW-24	Junction Box		1
24-1	HVBS-10-DMW-24-1	Cover		1
24-2	TS-2284082	Phillips Pan Hd Machine Screw	M4-0.7x8L	4
25	HVBS-10-DMW-25	Fixed Guide Arm		1
26	HVBS-10-DMW-26	Movable Guide Arm		1
27	HVBS-10-DMW-27	Fixed Guide Carbide		1
28	HVBS-10-DMW-28	Movable Guide Carbide		1
28-1	TS-1503061	Hex Socket Cap Screw	M6-1.0x25L	4
28-2	TS-1550041	Flat Washer	6x13x1 mm	4
28-3	TS-1504041	Hex Socket Cap Screw	M8-1.25x20L	2
28-4	BB-608ZZ	Bearing	608ZZ	2
28-5	TS-1523051	Set Screw	M6-1.0x16L	8
28-6	TS-1540061	Hex Nut	M8	4
28-7	TS-2361081	Lock Washer	M8	4
28-8	HVBS-10-DMW-28-8	Flat Washer	8x25x2 mm	2
29	HVBS-10-DMW-29	Handle	TR80 3/8x30L	1
30	HVBS-10-DMW-30	Bearing Shaft		2
30-1	BB-5200ZZ	Bearing	5200ZZ	4
30-2	PB85-115	E-clip	E7	4
31	HVBS-10-DMW-31	Eccentric Shaft		2
32	HVBS-10-DMW-32	Hydraulic Cylinder		1
	HVBS-10-DMW-32N	Hydraulic Cylinder (After serial #1701BK00017)		1
32-1	HVBS-10-DMW-32-1	Linch Pin		1
32-2	TS-2276081	Set Screw	M6x8	1
32-3	HVBS-10-DMW-32-3	Cylinder Pin		1
	HVBS-10-DMW-32-3N	Cylinder Pin (After serial #1701BK00017)		1
33	HVBS-10-DMW-33	Handle		1
33-1	TS-1540081	Hex Nut	M12-1.75	1
34	HVBS-10-DMW-34	Spring Holder		1
35	HVBS-10-DMW-35AS	Adjusting Screw Assembly	1/2"	1
35-1	TS-0561052	Hex Nut	1/2"-20	2
36	HVBS-10-DMW-36	Gearbox		1
36-1	TS-0081031	Hex Cap Bolt	5/16"-18NCx3/4"L	1
36-2	TS-0720081	Lock Washer	5/16"	1
36-3	TS-0680031	Washer	5/16"x30x3	1
36-4	TS-1524051	Set Screw	M8-1.25x20L	4
36-5	TS-0208041	Hex Socket Cap Screw	5/16-18NCx3/4"L	4
36-6	TS-0720081	Lock Washer	5/16"	4
37	TS-0270031	Set Screw	5/16"-18x3/8"	2
38	HVBS-10-DMW-38	Motor Tilt Plate		1
38-1	F000794	Phillips Pan Hd Machine Screw	5/16"-18NCx3/4L	4
38-2	F009919	Button Head Socket Screw	M5-0.8x6L	1
38-3	TS-1550031	Flat Washer	5x10x1 mm	1
38-4	TS-1523031	Set Screw	M6-1.0x10L	2
39	HVBS-10-DMW-39	Shaft		1
40	HVBS-10-DMW-40	Blade Guard		1
40-1	TS-1503021	Hex Socket Cap Screw	M6-1.0x10L	2
40-2	TS-1550041	Flat Washer	6x13x1 mm	2
41	HVBS-8-DMW-41	Motor Mount		1
42	HVBS-10-DMW-42	Blade Guard		1
	HVBS-10-DMW-42A	Blade Guard with Brush Assembly (#42,12,12-1,12-2,12-3)		1
42-1	TS-1503021	Hex Socket Cap Screw	M6-1.0x10L	1
42-2	TS-1550041	Flat Washer	6x13x1.5 mm	2
43	HVBS-8-DMW-42	Handle		1
43-1	HVBS-8-DMW-40	Adjusting Nut		1
43-2	TS-1503031	Hex Socket Cap Screw	M6-1.0x12L	2
43-3	HVBS-8-DMW-37	Collar		1

Index No	Part No	Description	Size	Qty
43-4	TS-2361061	Lock Washer	M6	2
44	TS-1482021	Hex Cap Bolt	M6-1.0x12L	4
44-1	TS-2361061	Lock Washer	M6	4
44-2	TS-1550041	Flat Washer	6x13x1 mm	4
45	HVBS-10-DMW-45	Motor	1HP 115/230V 1PH	1
	HVBS-10-DMW-45SC	Start Capacitor	300MFD 125VAC	1
	HVBS-10-DMW-45RC	Running Capacitor	30µF 250VAC	1
	HVBS-10-DMW-45JB	Junction Box		1
	HVBS-10-DMW-45JBC	Junction Box Cover		1
	HVBS-10-DMW-45MF	Motor Fan		1
	HVBS-10-DMW-45MFC	Motor Fan Cover		1
45-1	HVBS-10-DMW-45-1	Key, Double Rd Hd	5x41 mm	1
46	HVBS-10-DMW-46	Hose Fitting	1/4" PT	1
47	HVBS-10-DMW-47	Pulley Box		1
47-1	TS-1482021	Hex Cap Bolt	M6-1.0x12L	2
47-2	TS-2361061	Lock Washer	M6	2
47-3	TS-1550041	Flat Washer	6x6x1.5 mm	2
48	HVBS-8-DMW-48	Motor Pulley		1
49	VB-A27	V-Belt	A27	1
50	HVBS-8-DMW-50	Gearbox Pulley		1
51	HVBS-8-DMW-52	T-Block		2
51-1	TS-0209061	Hex Socket Cap Screw	3/8"-16NCx1-1/4"L	1
51-2	TS-0680041	Flat Washer	3/8"x29x3	2
52	HVBS-8-DMW-57	Shaft Seat		1
53	HVBS-8-DMW-53	Collar		2
54	TS-1524011	Set Screw	M8-1.25x8L	2
55	HVBS-8-DMW-55	Bow Bearing Shaft		1
56	HVBS-8-DMW-56	Bracket		1
56-1	TS-1503061	Hex Socket Cap Screw	M6-1.0x25L	2
56-2	TS-2311061	Hex Nut	M6-1.0	2
56-3	TS-1540081	Hex Nut	M12-1.75	1
56-4	HVBS-10-DMW-56-4	Threaded Rod	M12-17.5x70L	1
56-5	TS-2360121	Flat Washer	12x24x3 mm	2
56-6	HVBS-10-DMW-56-6	Threaded Rod	M12-17.5x62L	1
57	F009536	Hex Socket Cap Screw	M12-1.75x30L	2
57-1	TS-2360121	Flat Washer	12x24x3 mm	2
57-2	TS-2361121	Lock Washer	M12	2
58	HVBS-8-DMW-58	Plate		1
58-1	TS-1492021	Hex Cap Bolt	M12-1.75x30L	2
58-2	BB-6001ZZ	Bearing	6001ZZ	2
58-3	TS-2361121	Lock Washer	M12	2
58-4	TS-1540081	Hex Nut	M12-1.75	2
59	HVBS-10-DMW-59	Special Washer		4
60	TS-1504041	Hex Socket Cap Screw	M8-1.25x20L	4
61	HVBS-8-DMW-61	Indicator		1
61-1	F009920	Button Head Socket Screw	M6-1.0x6L	1
61-2	HVBS-10-DMW-61-2	Flat Washer	6x6x1.5 mm	1
62	HVBS-8-DMW-62	Support		1
62-1	TS-1504051	Hex Socket Cap Screw	M8-1.25x25L	2
62-2	TS-2361081	Lock Washer	M8	1
62-3	TS-1550061	Flat Washer	8x16x1.0 mm	2
62-4	TS-1540061	Hex Nut	M8-1.25	2
63	HVBS-8-DMW-63	Handle	TRT100 M12	1
64	HVBS-8-DMW-64	Support Plate		1
65	HVBS-10-DMW-65	Tension Spring		1
65-1	HVBS-10-DMW-65-1	Spring Hook	5x50mm	4
66	HVBS-10-DMW-66	Lower Swivel Guide		1
67	HVBS-8-DMW-60	Angle Scale		1
67-1	F009919	Button Head Socket Screw	M5-1.0x6L	3
68	HVBS-10-DMW-68	Fixed Vise Jaw		1
68-1	TS-1504051	Hex Socket Cap Screw	M8-1.25x25L	4
68-2	TS-2361081	Lock Washer	M8	4

Index No	Part No	Description	Size	Qty
68-3	TS-1550061	Flat Washer	8x18x2 mm	4
69	TS-1504071	Hex Socket Cap Screw	M8-1.25x35L	2
70	TS-1550061	Flat Washer	8x25x3 mm	2
70-1	TS-2361081	Lock Washer	M8	2
71	HVBS-10-DMW-71	Aluminum Miter Plate		1
71-1	TS-1503051	Hex Socket Cap Screw	M6-1.0x20L	4
71-2	TS-2361061	Lock Washer	M6	4
71-3	TS-1550041	Flat Washer	6x16x2 mm	4
72	HVBS-10-DMW-72	Movable Jaw Mount		1
72-1	HVBS-10-DMW-72-2	Spacer		1
72-2	HVBS-10-DMW-72-2	Vise Lock Knob		1
72-3	TS-1504091	Hex Socket Cap Screw	M8-1.25x45L	2
72-4	TS-2361081	Lock Washer	M8	2
72-5	TS-1550061	Flat Washer	8x16x1.0 mm	2
73	HVBS-10-DMW-73	Movable Jaw Assembly		1
74	HVBS-10-DMW-74	Bed		1
75-4	TS-1504041	Hex Socket Cap Screw	M8x20	2
75-5	TS-2361081	Lock Washer	M8	2
75-6	TS-0680031	Flat Washer	5/16"	2
75	HVBS-10-DMW-75	Bed Support		2
75-1	F005670	Hex Socket Cap Screw	M12-1.75x15L	2
75-2	TS-2361121	Lock Washer	M12	2
75-3	TS-2360121	Flat Washer	12x24x3 mm	2
76	HVBS-8-DMW-69	Chip Deflector		1
76-1	TS-2246102	Button Head Socket Screw	M6-1.0x10L	1
77	HVBS-8-DMW-78	45-Degree Plate (right)		1
77-1	TS-1550041	Flat Washer	6x13x1 mm	4
77-2	TS-1503051	Hex Socket Cap Screw	M6-1.0x20L	4
77-3	TS-1490041	Hex Cap Bolt	M8-1.25x25L	2
77-4	TS-1540061	Hex Nut	M8	2
77-5	HVBS-8-DMW-78-5	45-Degree Plate (left)		1
78	HVBS712-15	Work Stop		1
78-1	HVBS712-13	Threaded Collar		1
78-2	HVBS712-14	Plastic Knob		1
78-3	HVBS712-17	Lower Work Stop Rod		1
78-4	TS-1490031	Hex Cap Bolt	M8-1.25x20L	1
78-5	HVBS-8-DMW-80-1	Upper Work Stop Rod		1
79	HVBS-8-DMW-82	Vertical Cutting Platform		1
80	F009536	Hex Socket Cap Screw	M12-1.75x30L	3
80-1	TS-2361121	Lock Washer	M12	3
80-2	TS-2360121	Flat Washer	12x28x3 mm	3
81	HVBS-8-DMW-86	Handle		1
81-1	TS-1503061	Hex Socket Cap Screw	M6x25	1
81-2	TS-2311061	Hex Nut	M6	1
82	HVBS-10-DMW-82	Chip Drawer		1
83	HVBS-8-DMW-84	Swivel Caster	411 PU	2
83-1	TS-0561052	Hex Nut	1/2"-20	2
84	HVBS-10-DMW-84	Coolant Tray		1
85	HVBS-10-DMW-85	Coolant Pump *	1/8HP 2P 1PH	1
85-1	TS-2286252	Phillips Pan Hd Machine Screw *	M6-1.0x25L	4
85-2	HVBS-10-DMW-85-2	Pipe *		1
85-3	HVBS-10-DMW-85-3	Metal Cable Tie *		1
85-4	HVBS-10-DMW-85-4	Hose Fitting	3/8Px5/16	2
86	HVBS-8-DMW-86-3	Grip		1
87	HVBS-10-DMW-87	Bracket (LH)		1
88	HVBS-10-DMW-88	Bracket (RH)		1
89	HVBS-8-DMW-85	Carriage		1
89-1	F001200	Phillips Pan Hd Machine Screw	M5-0.8x6	1
90	TS-1550041	Flat Washer	6x13x1 mm	4
91	TS-2311061	Hex Nut	M6	7
92	HVBS-8-DMW-88	Wheel		2
93	HVBS-10-DMW-93	Spacer (long)		4

Index No	Part No	Description	Size	Qty
93-1	HVBS-10-DMW-93-1	Spacer (short)		2
94	TS-0561071	Hex Nut	5/8"-11	2
94-1	TS-0680081	Flat Washer	5/8"	2
95	HVBS-10-DMW-95	Axle Bolt	5/8x5"	2
96	HVBS-10-DMW-96	Chip Screen		1
97	HVBS-10-DMW-97	Chip Bin Bottom Panel		1
98	HVBS-10-DMW-98	Button Head Socket Screw	M6-1.0x10L	7
99	HVBS-10-DMW-99	Chip Bin Left Panel		1
100	HVBS-10-DMW-100	Chip Bin Right Panel		1
101	HVBS-10-DMW-101	Holder		1
101-1	F012620	Hex Cap Bolt	M8-1.25x8L	2
101-2	TS-2361081	Lock Washer	M8	2
101-3	TS-1540061	Hex Nut	M8	2
101-4	TS-1481021	Hex Cap Bolt	M5-0.8x10	2
101-5	TS-2361051	Lock Washer	M5	2
101-6	TS-1550031	Flat Washer	5mm	2
102	HVBS-10-DMW-102	PU Hose (not shown)	5/16" x 5ft	1
	JET-138	JET Logo (not shown)	138x57mm	1
	LM000270	ID Label, HVBS-10DMW (not shown)		1
	LM000269	Label, Blade Speeds (not shown)		1
	LM000271	Warning Label (not shown)		1

* coolant pump provided only with model #424465 (optional accessory for #424463 model)