



SERVICE PARTS LIST

VAC-U-RIG

Catalog No. **4110**

Starting
Serial No.

BUL.54-46-1100

REVISED BUL.
54-46-1100

DATE
July '80

WIRING INSTRUCTIONS
58-01-0661

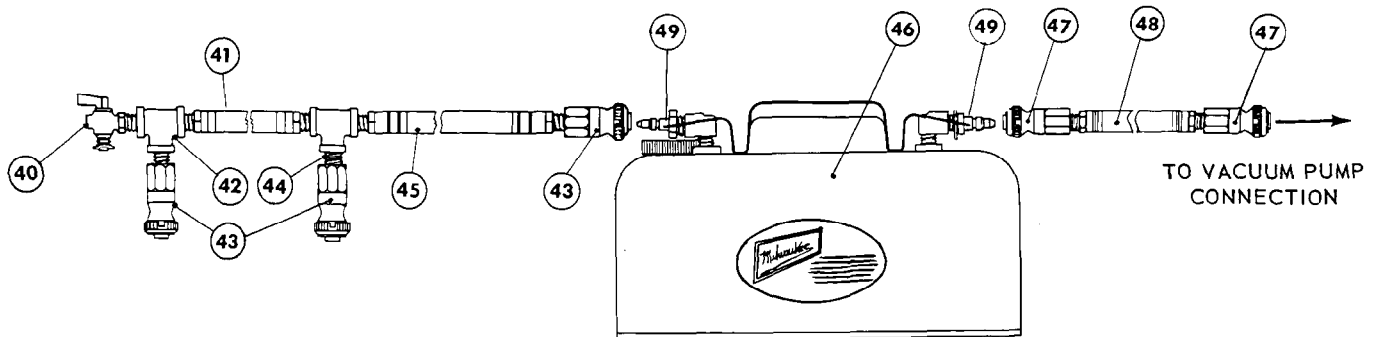
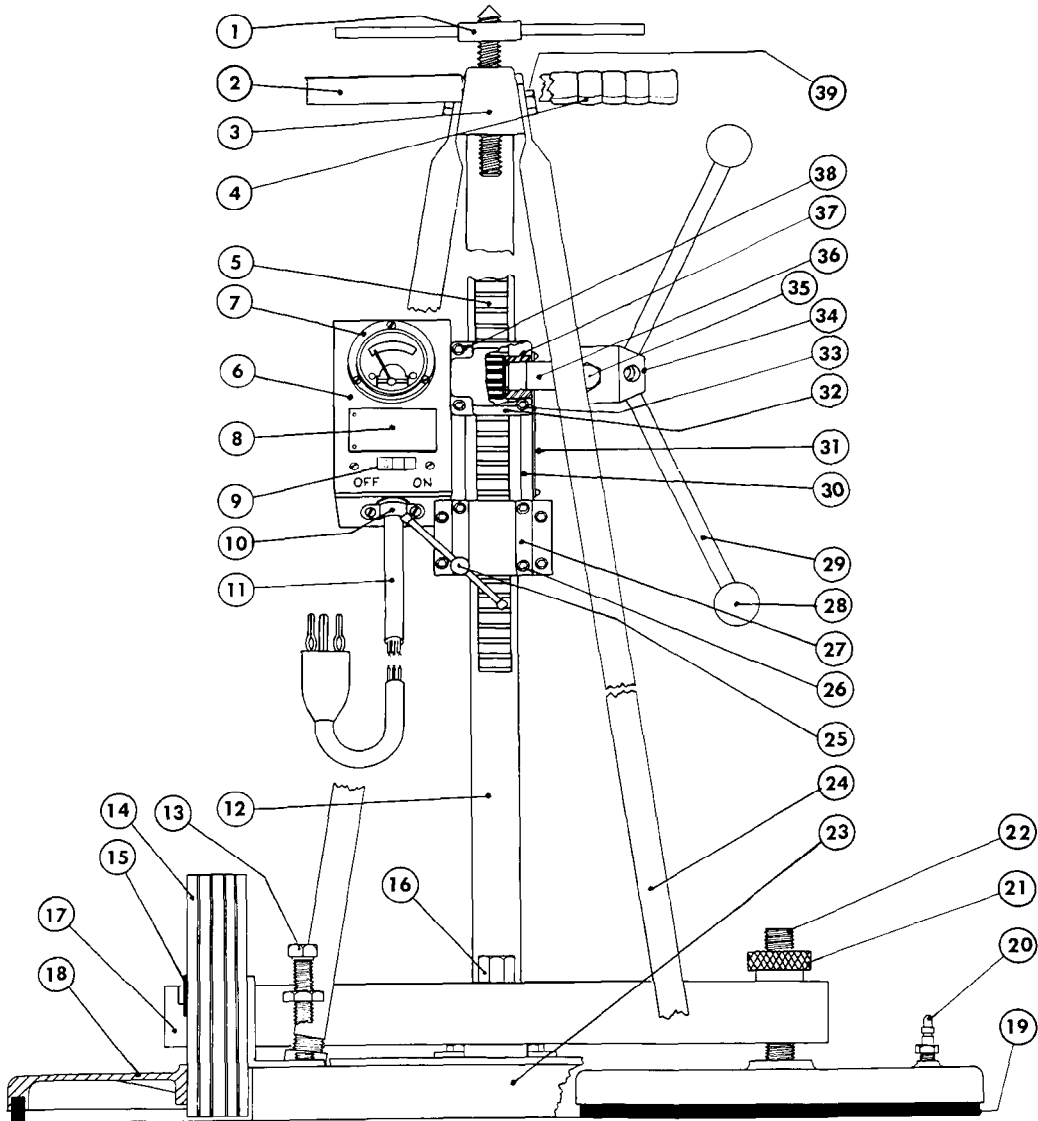



SERVICE PARTS LIST

4110 VAC-U-RIG

FIG.	PART NO.	DESCRIPTION OF PART	NO. REQ.
1	45-04-0060	Jack Screw Assembly	(1)
2	43-62-0250	Pipe Handle	(2)
3	28-10-0401	Bracket	(1)
4	43-62-0240	Handle Grip	(2)
5	44-80-0101	Rack	(1)
★ 6	14-06-0050	Switch Box Assembly (See Note)	(1)
7	22-04-0160	Ammeter	(1)
8	12-17-2500	Nameplate	(1)
9	23-66-0070	Switch	(1)
★ 10	22-56-0245	Connector	(1)
★ 11	22-64-0075	Cord Set	(1)
12	14-10-0100	Column Assembly	(1)
13	06-83-5150	5' 8-11x4-1/2 Sq. Hd. Leveling Screw	(2)
14	45-94-0080	Wheel	(2)
15	34-60-1450	Retaining Ring	(2)
16	06-75-0970	1/2-13x2-3/4 Hex. Screw	(1)
17	42-18-0070	Cross Bar	(1)
18	14-14-0100	Vacuum Disc Assembly (Includes Fig. 19)	(2)
19	43-44-0090	Gasket	(2)
20	42-90-0110	Coupling	(2)
21	44-40-0200	Hold Down Nut	(2)
22	06-92-2000	Vacuum Disc Stud	(2)
23	42-20-0091	Base Assembly	(1)
24	45-60-0101	Column Support	(2)
25	45-04-0150	T-Screw Assembly	(1)
26	06-75-3100	1/4-20x1 Skt. Hd. Cap Screw	(3)
27	30-16-2001	Column Clamp Cap	(1)
★ 28	43-98-0050	Plastic Knob	(4)
★ 29	43-62-0050	Handle	(4)
30	30-24-0402	Cradle	(1)
31	12-17-2030	Nameplate	(1)
32	30-16-6001	Pinion Cap	(1)
33	06-75-3250	1/4-20x1-1/2 Skt. Hd. Cap Screw	(2)
★ 34	43-78-0056	Handle Hub	(1)
35	06-75-0875	1/2-13x1-3/4 Hex. Hd. Cap Screw	(1)
36	36-66-0751	Pinion Shaft	(1)
37	42-40-0060	Bushing	(1)
38	06-75-3100	1/4-20x1 Skt. Hd. Cap Screw	(2)
39	06-75-5700	1/2-13x1 Skt. Hd. Cap Screw	(2)
40	45-80-0080	Aircock Valve	(1)
41	14-37-0100	12" Hose Assembly	(1)
42	43-33-0200	1/4" Tee	(2)
43	42-90-0120	Coupling	(3)
44	43-33-0210	1/4" Close Nipple	(2)
45	14-37-0150	96" Hose Connection Assembly	(1)
46	49-76-0060	Vacuum Reserve Tank Assy. (Includes Figs. 47 thru 49)	(1)
47	42-90-0120	Female Disconnect	(2)
48	14-37-0100	12" Hose Assembly	(1)
49	42-90-0110	Coupling	(2)
★ 50	49-50-0115	Vacuum Pump Assembly (Not Shown - Refer to Catalog No. 49-50-0115 Parts List)	(1)

NOTE: 14-06-0050 Switch Box Assembly Includes Fig. Nos. 7 thru 11 and The Following Parts: (Not Shown)

PART NO.	DESCRIPTION OF PART	NO. REQ.
06-55-0600	6-32 Hex Nut	(2)
06-55-0825	8-32 Hex Nut	(4)
06-75-2400	10-32x1/2 Socket Hd. Screw	(2)
★ 06-81-0400	8-32x 3/4 Pan Hd. Screw	(2)
06-81-8650	6-32x1/4 Rd. Hd. Receptacle Mtg. Screw	(4)
06-85-0200	Nameplate Screw	(2)
06-97-0870	Shakeproof Washer	(2)
06-97-2000	Internal Tooth Lockwasher	(4)
06-97-2600	Lockwasher	(2)
12-17-2700	Outlet Plate	(1)
22-12-0011	Switch Box	(1)
★ 22-56-0131	Receptacle	(1)
22-68-0050	Switch Box Cover	(1)
23-74-0310	Terminal	(2)
★ 23-74-0395	Terminal	(4)
★ 23-74-0550	Terminal	(2)

MISCELLANEOUS PARTS NOT SHOWN

PART NO.	DESCRIPTION OF PART	NO. REQ.
06-55-3250	5/8-11 Leveling Screw Nut	(2)
06-65-0830	1/8x1/2 No. 5 Groove Pin	(1)
06-75-2400	10-32x1/2 Skt. Hd. Cap Screw	(2)
06-75-3100	1/4-20x1 Skt. Hd. Drill Mtg. Cap Screw	(4)
06-75-3250	1/4-20x1-1/2 Skt. Hd. Cap Screw	(3)
06-75-5700	1/2-13x1 Skt. Hd. Cap Screw	(2)
06-75-5800	1/2-13x1-1/2 Skt. Hd. Cap Screw	(1)
06-81-6150	8-32x1/2 Fil. Hd. Key Retaining Sem	(1)
06-83-2840	5/16-18x5/8 Skt. Hd. Set Screw	(2)
06-85-0200	6x1/4 Rd. Hd. Type Z Screw	(2)
06-97-3800	Lock Washer	(11)
06-97-4200	1/2" Split Ring Lockwasher	(4)
43-96-0060	Key	(1)
44-08-0060	Bubble Level Assembly	(1)
44-66-0330	Adjustment Plate	(1)
49-96-0070	5/32" Socket Wrench	(1)
49-96-0085	3/16" Socket Wrench	(1)
★ 12-98-7082	Caution Plate	(1)

240V DYMORIG (4110-2)

SAME AS 4110 EXCEPT:
 FIG. NO. 6 14-06-0060 SWITCH BOX ASSY.
 FIG. NO. 7 22-04-0170 AMMETER
 FIG. NO. 11 22-64-4000 CORD SET
 22-56-0132 RECEPTICAL
 DELETE 12-17-2700 OUTLET PLATE