



SERVICE PARTS LIST

DRILL STAND

Catalog No. **4100**

Starting
Serial No.

BUL.54-46-1000

REVISED BUL. DATE
June '75

WIRING INSTRUCTIONS
58-01-0661

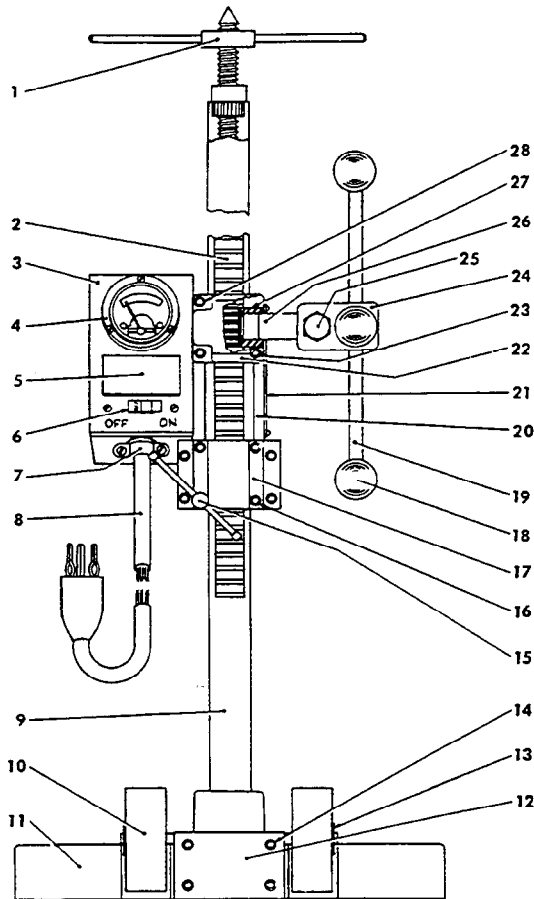

NOTE: 14-06-0050 Assembly Includes Ref. Nos. 4 thru 8 & The Following Parts: (Not Shown)

PART NO.	DESCRIPTION OF PART	NO. REQ.
06-55-0600	6-32 Hex Nut	(2)
06-55-0825	8-32 Hex Nut	(4)
06-75-2400	10-32x1/2 Skt. Hd. Screw	(2)
★ 06-81-0400	8-32x3/4 Pan Hd. Screw	(2)
06-81-8650	6-32x1/4 Rd. Hd. Sem	(4)
06-85-0200	6x1/4 Rd. Hd. Type Z Screw	(6)
06-97-0870	Shakeproof Washer	(2)
06-97-2000	Internal Tooth Lock Washer	(4)
06-97-2600	Lock Washer	(2)
12-17-2700	Outlet Plate	(1)
22-12-0011	Switch Box	(1)
★ 22-56-0131	Receptical	(1)
22-68-0050	Switch Box Cover	(1)
23-74-0310	Terminal	(2)
★ 23-74-0395	Terminal	(4)
★ 23-74-0550	Terminal	(2)

FIG.	PART NO.	DESCRIPTION OF PART	NO. REQ.
	1	Jack Screw Assembly	(1)
	2	Gear Rack	(1)
	3	Switch Box Assembly (See Note)	(1)
	4	Ammeter	(1)
	5	Nameplate	(1)
	6	Switch	(1)
	7	3/4" Straight Connector	(1)
★	8	Cord Set	(1)
	9	Column	(1)
	10	45-94-0050 Wheel	(2)
	11	28-06-0401 Dymorig Base	(1)
	12	42-36-0061 Bracket Shaft Assembly	(1)
	13	34-60-1000 Retaining Ring	(4)
	14	06-81-4700 1/4-20x1/2 Rd. Hd. Screw	(4)
	15	45-04-0150 T-Screw Assembly	(1)
	16	06-75-3100 1/4-20x1 Skt. Hd. Cap Screw	(3)
	17	30-16-2001 Column Clamp Cap	(1)
	18	43-98-0050 Plastic Knob	(3)
	19	43-62-0050 Handle	(3)
	20	30-24-0402 Cradle	(1)
	21	12-17-2040 Name Plate	(1)
	22	30-16-6001 Pinion Cap	(1)
	23	06-75-3250 1/4-20x1 Skt. Hd. Cap Screw	(2)
	24	43-78-0050 Capstan Hub	(1)
	25	06-75-0875 1/2-13x1-3/4 Cap Screw	(1)
	26	36-66-0751 Pinion Shaft	(1)
	27	42-40-0060 Pinion Shaft Bushing	(1)
	28	06-75-3100 1/4-20x1 Skt. Hd. Cap Screw	(2)

MISCELLANEOUS PARTS NOT SHOWN

PART NO.	DESCRIPTION OF PART	NO. REQ.
06-55-2850	1/2-13 Hex Nut	(4)
06-65-0830	1/8x1/2 No. 5 Groove Pin	(1)
06-75-0950	1/2-13x2-1/2 Hex. Hd. Cap Screw	(2)
06-75-2400	10-32x1/2 Skt. Hd. Cap Screw	(2)
06-75-3100	1/4-20x1 Skt. Hd. Cap Screw (Drill Mounting)	(4)
06-75-3250	1/4-20x1-1/2 Skt. Hd. Cap Screw	(3)
06-81-6150	8-32x1/2 Fil. Hd. Sem (Key Retaining)	(1)
06-83-2840	5/16-18x5/8 Hdls. Set Screw	(2)
06-83-4950	1/2-13x3 Square Hd. Set Screw	(4)
06-85-0200	Nameplate Screw	(4)
06-97-3800	1/4" Lock Washer	(15)
06-97-4200	1/2" Split Ring Lock Washer	(2)
43-96-0060	Key	(1)
44-08-0060	Bubble Level Assembly	(1)
44-66-0330	Adjustment Plate	(1)
49-96-0070	5/32" Socket Wrench	(1)
49-96-0085	3/16" Socket Wrench	(1)
12-98-7081	Caution Plate	(1)

240V DYMORIG (4100-2)

SAME AS 4100 EXCEPT:
 FIG. NO. 3 14-06-0060 SWITCH BOX ASSY.
 FIG. NO. 4 22-04-0110 AMMETER
 FIG. NO. 8 22-64-2075 CORD SET
 22-56-0132 RECEPTICAL
 DELETE 12-17-2700 OUTLET PLATE