



SERVICE PARTS LIST

BULLETIN NO.
54-16-2081

SPECIFY CATALOG NO. AND SERIAL NO. WHEN ORDERING PARTS		REVISED BULLETIN 54-16-2080	DATE April '84
TWO SPEED DYMODRILL			
CATALOG NO. 4029	STARTING SERIAL NO. 560-8001	WIRING INSTRUCTION 58-01-0395	
CAT. NO. 4029-6	START SER. NO. 560-8001	BILINGUAL LABEL 10-98-6120	

**FOR CAT. NO. 4029-2
(240V) TOOL USE:**
16-76-0075 ARMATURE
18-76-0060 FIELD
22-64-4300 CORD SET

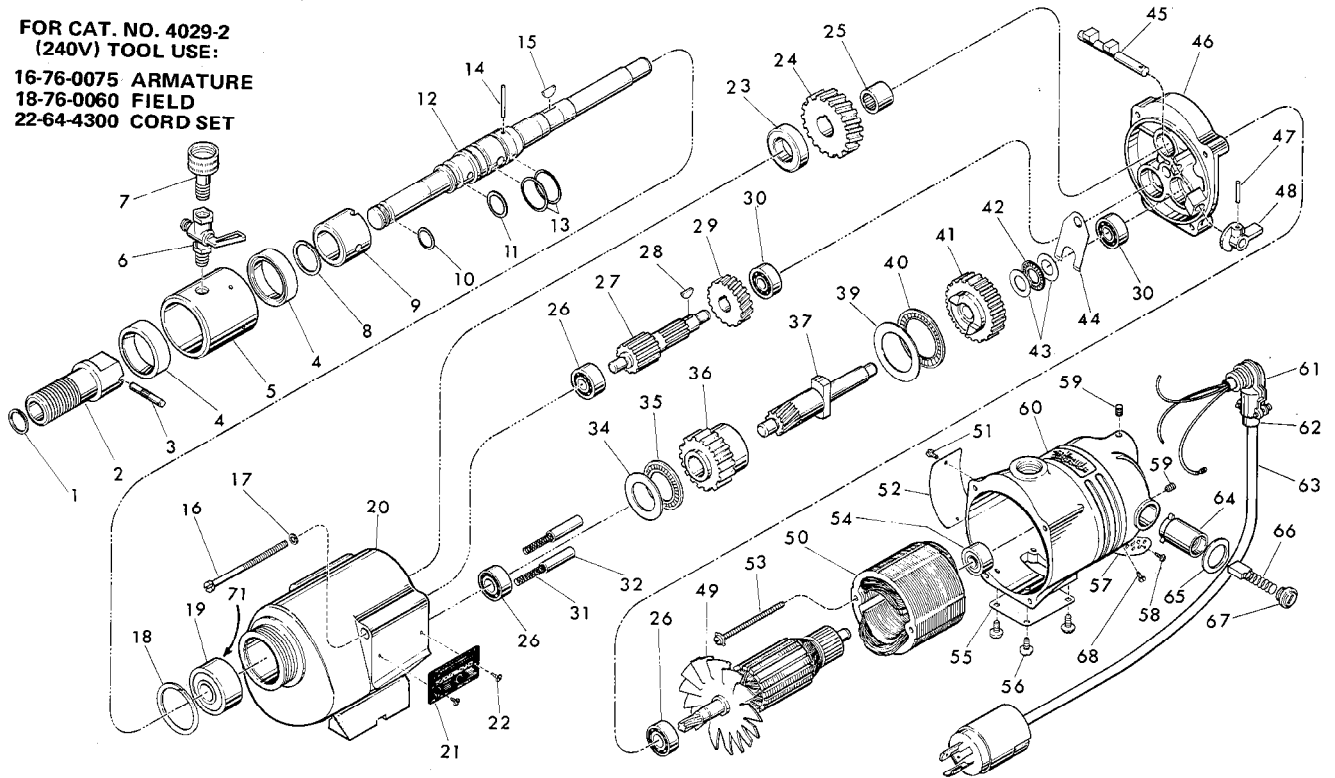

FIG.	PART NO.	DESCRIPTION OF PART	NO. REQ.	FIG.	PART NO.	DESCRIPTION OF PART	NO. REQ.
	1	34-60-1800 Retaining Ring	(1)	35	02-80-1800 Thrust Bearing	(1)	
	2	45-22-0050 Spindle Sleeve	(1)	36	32-10-0061 Clutch Gear Assembly	(1)	
	3	44-60-0050 Shear Pin	(1)	37	36-14-0071 Clutch Pinion Shaft Assembly	(1)	
	4	45-06-0050 Trostel Seal	(2)	39	45-88-0530 Thrust Bearing Washer	(1)	
	5	43-76-0051 Water Swivel Housing (W/06-83-2430 Set Screw)	(1)	40	02-80-5000 Thrust Bearing	(1)	
	6	45-80-0060 Shut Off Valve	(1)	41	32-10-0051 Clutch Gear Assembly	(1)	
	7	42-04-0600 Water Hose Adapter	(1)	42	02-80-1200 Thrust Bearing	(1)	
	8	34-60-2115 Retaining Ring	(1)	43	45-88-0510 Thrust Bearing Washer	(2)	
	9	42-40-0391 Spindle Bushing	(1)	44	45-98-0090 Shifting Yoke	(1)	
	10	34-40-1100 O-Ring	(1)	★45	30-15-0270 Shifting Cam	(1)	
	11	34-40-1200 O-Ring	(1)	★46	28-28-1370 Diaphragm (Includes 06-65-0680 Groove Pin)	(1)	
	★12	38-50-4555 Spindle	(1)	47	06-65-0840 1/8x3/4 Groove Pin	(1)	
	13	34-40-1350 O-Ring	(2)	48	28-60-0056 Shift Cam Knob	(1)	
	14	06-65-1530 1/8x1/2 Roll Pin	(1)	49	16-70-0065 120V. Armature	(1)	
	15	06-42-2400 Woodruff Key No. 61	(1)	50	18-70-0060 120V. Field	(1)	
	16	06-81-2125 1/4-20x3-1/2 Fil. Hd. Screw (See Note).	(4)	51	06-85-0200 6x1/4 Rd. Hd. Type Z Screw	(2)	
	17	06-97-3800 Lock Washer	(4)	52	12-99-0040 Nameplate Blank	(1)	
	18	34-80-3800 Retaining Ring	(1)	53	06-81-9225 10-24x2-3/4 Rd. Hd. Sem	(2)	
	★19	02-20-2515 Ball Bearing	(1)	54	02-04-1070 Ball Bearing	(1)	
	★20	28-14-1665 Gear Case Assy. (Includes 44-60-0320 Pivot Pin and 06-65-1535 Roll Pin)	(1)	55	44-66-0050 Body Cover Plate	(1)	
	21	12-98-2100 Instruction Plate	(1)	56	06-81-5000 1/4-20x3/8 Truss Hd. Screw	(4)	
	22	06-81-5789 4-40x1/4 Pan Hd. Taptite Screw	(2)	57	44-66-0180 Cover Plate	(1)	
	★23	45-36-1245 Spacer	(1)	58	06-81-8650 6-32x1/4 Rd. Hd. Sem	(2)	
	24	32-75-2661 Spindle Gear	(1)	59	06-83-2650 1/4-20x3/8 Knrl. Set Screw	(3)	
	25	02-50-4830 Needle Bearing	(1)	★60	28-50-4122 Motor Housing (Incl 45-30-0110 BB Rtnng Slug)	(1)	
	26	02-04-1260 Ball Bearing	(3)	61	22-56-0060 Squeeze Connector	(1)	
	27	36-66-3751 Pinion Shaft Assembly	(1)	62	44-76-0100 Strain Relief	(1)	
	28	06-42-1600 Woodruff Key No. 304	(1)	63	22-64-0055 Cord Set (Includes 23-36-0120 Plug)	(1)	
	29	32-40-1581 Intermediate Gear	(1)	64	22-22-1015 Brush Holder Assembly	(2)	
	30	02-04-1205 Ball Bearing	(2)	65	23-86-0060 Insulating Washer	(2)	
	31	40-50-6300 Shifting Spring	(2)	66	22-18-0055 Carbon Brush Assembly	(2)	
	32	44-70-0100 Shifting Plunger	(2)	67	23-44-0030 Brush Retaining Screw	(2)	
	34	45-88-0520 Thrust Bearing Washer	(1)	68	06-81-8625 6-32x1/4 Ground Screw	(1)	
				▶69	12-98-7082 Caution Plate (Not Shown)	(1)	
				70	49-96-4700 1-3/8" Open End Wrench (Not Shown)	(1)	
				★71	45-36-1240 Bearing Spacer (Not Shown)	(1)	
				▶	Omit for Canadian Tools		

NOTE
16 Apply Type 242 Blue Loctite and Torque to 65-85 In. Lbs.