



# Operating Instructions and Parts Manual 20" Variable Speed Drill Press

Models: JDP-20VS-1, JDP-20VS-3, JDP-20VST



JDP-20VST

JDP-20VS

**JET**  
427 New Sanford Road  
LaVergne, Tennessee 37086  
Ph.: 800-274-6848  
[www.jettools.com](http://www.jettools.com)

**Part No. M-354230**  
Edition 5 10/2018  
Copyright © 2017 JET

13.1.1 Drill Head – Manual Speed Control (JDP-20VS-1/3) – Exploded View

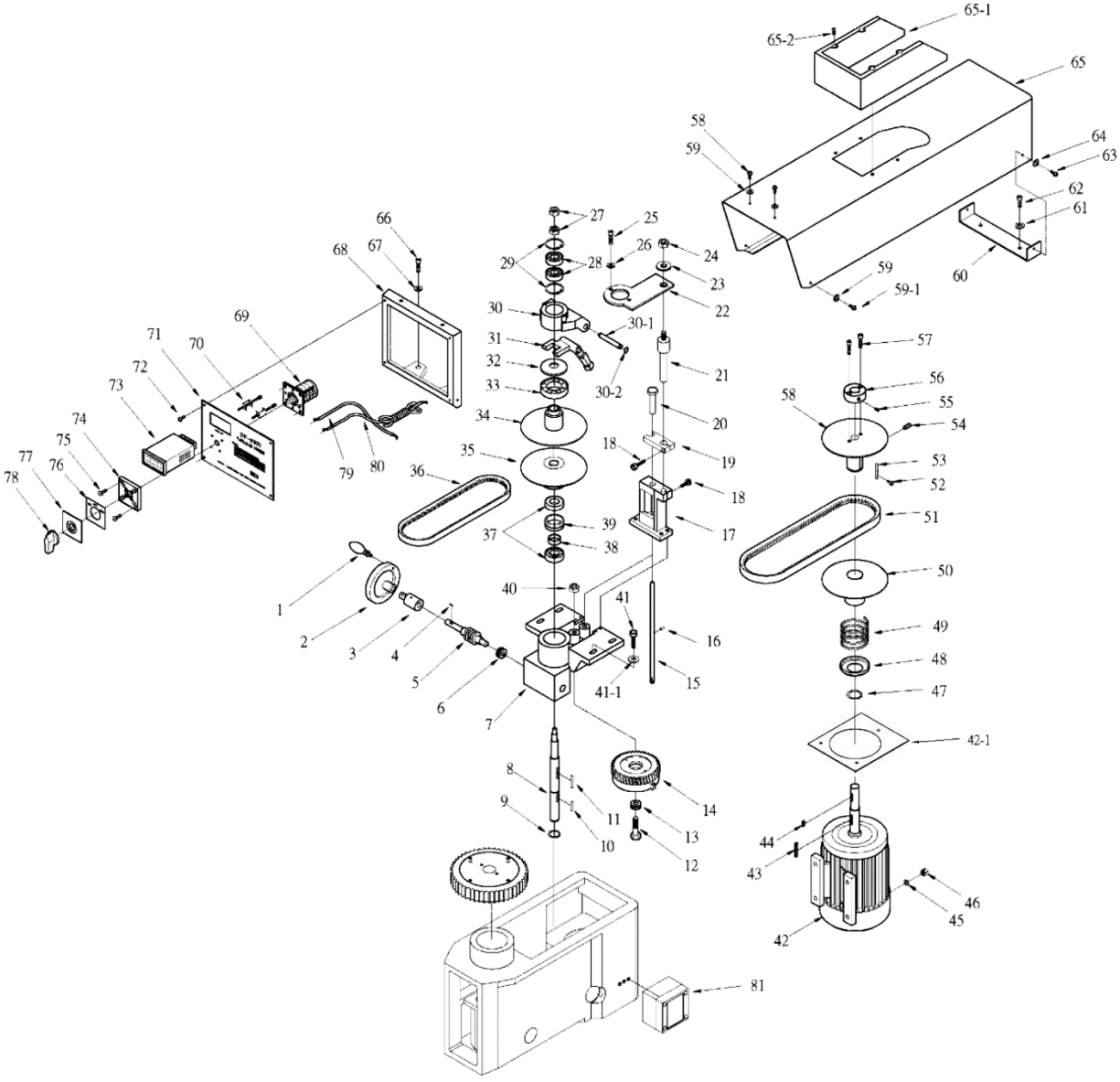

### 13.1.2 Drill Head – Manual Speed Control (JDP-20VS-1/3) – Parts List

Index No.	Part No.	Description	Size	Qty
1	5510126	Hand Grip		1
2	5510126	Handwheel (includes #1)		1
3	JDP20VS-TH03	Bushing		1
4	JDP20VS-TH04	Key	4x4x15 mm	1
5	JDP20VS-TH05	Worm Shaft		1
6	BB-51101ZZ	Thrust Bearing	51101zz	1
7	JDP20VS-TH07	Bearing Housing		1
8	JDP20VS-TH08	Spindle Mid Shaft		1
9	5519933	C-Ring, External (shaft)	S-25	1
10	6293358	Key, Double Rd Head	5x5x25 mm	1
11	5784011	Key, Double Rd Head	5x5x40 mm	1
12	JDP20VS-TH12	Shaft		1
13	BB-51101ZZ	Thrust Bearing	51101zz	1
14	JDP20VS-TH14	Worm Shaft		1
15	JDP20VS-TH15	Control Rod		1
16	6286786	Roll Pin	4x15 mm	1
17	JDP20VS-TH17	Housing		1
18	TS-1503051	Hex Socket Cap Screw	M6x20	1
19	JDP20VS-TH19	Bracket		1
20	JDP20VS-TH20	Control Rod Sleeve		1
21	JDP20VS-TH21	Shaft		1
22	JDP20VS-TH22	Plate		1
23	TS-0720131	Spring Washer	5/8"	1
24	TS-0640132	Hex Nut	5/8"-18UNF	1
25	TS-1504041	Hex Socket Cap Screw	M8x20	2
26	TS-0680031	Washer	5/16"	2
27	9056311	Hex Nut	7/16"-20UNF	2
28	BB-6302ZZ	Ball Bearing	6302zz	2
29	F006077	C-Ring, Internal (Hole)	R-42	1
30	JDP20VS-TH30	Speed Change Bracket		1
30-1	JDP20VS-TH30-1	Support Rod		1
30-2	6286478	C-Ring, External (Shaft)	S-12	2
31	JDP20VS-TH31	Speed Change Lever		1
32	JDP20VS-TH32	Bearing Cover		1
33	BB-6207ZZ	Ball Bearing	6207zz	1
34	JDP20VS-TH34	Upper Spindle Pulley		1
35	JDP20VS-TH35	Lower Spindle Pulley		1
36	8M640	Belt	8Mx640	1
37	BB-6205ZZ	Ball Bearing	6205zz	2
38	JDP20VS-TH38	Bushing		1
39	JDP20VS-TH39	Bushing		1
40	TS-0561052	Hex Nut	1/2"-20UNF	1
41	TS-1504071	Hex Socket Cap Screw	M8x35	4
41-1	TS-0680031	Washer	5/16"	4
42	JDP20VS-TH42/1	Motor	4P/1Ph	1
	JDP20VS-TH42/2	Motor	4P/3Ph	1
42-1	JDP20VS-TH42-1	Plate		1
43	S0400545	Key, Double Rd Head	5x5x45 mm	1
44	5510675	Key, Double Rd Head	5x5x20 mm	1
45	TS-0680031	Washer	5/16"	4
46	JDP20VS-TH46	Hex+C26. Screw	M8x25	4
47	JDP20VS-TH47	C-Ring (Shaft)	S-45	1
48	JDP20VS-TH48	Spring Cover		1
49	JDP20VS-TH49	Spring		1
50	JDP20VS-TH50	Lower Motor Pulley		1
51	JDP20VS-TH51	Belt	1922V443	1
52	TS-1532032	Pan Head Screw	M4x10	4
53	JDP20VS-TH53	Key		2
54	TS-1522021	Set Screw	M5x8	1
55	TS-1524011	Set Screw	M8x8	2
56	JDP20VS-TH56	Bushing		1
57	TS-1503051	Hex Socket Cap Screw	M6x20	2
58	JDP20VS-TH58	Upper Motor Pulley		1

Index No.	Part No.	Description	Size	Qty
59	TS-0680021	Washer	1/4"	4
59-1	F009885	Button Head Socket Screw	M5x10	4
60	JDP20VS-TH60	Plate Bracket		1
61	TS-0680031	Washer	5/16"	2
62	TS-1504041	Hex Socket Cap Screw	M8x20	2
63	F000299	Phillips Pan Hd Machine Screw	1/4"x1/2"	2
64	TS-0680021	Washer	1/4"	2
65	JDP20VS-TH65	Pulley Cover		1
65-1	JDP20VS-TH65-1	Top Cover		1
65-2	F009669	Hex Socket Button Screw	#10-24UNCx3/8"	4
66	TS-1504061	Hex Socket Cap Screw	M8x30	2
67	TS-0680031	Washer	5/16"	2
68	JDP20VS-TH68	Plate Bracket		1
69	JDP20VS-TH69-1	Fwd/Rev Switch Assembly 1PH (includes # 74~78)		1
	JDP20VS-TH69-3	Fwd/Rev Switch Assembly 3PH (includes # 74~78)		1
70	JDP20VS-TH70	Cap Screw		2
71	JDP20VS-TH71	Face Plate		1
72	TS-1533032	Phillips Pan Hd Machine Screw	M5x10	4
73	5513519	LED Display for 1ph	115/230/24V	1
	5513736	LED Display for 3ph	220/440	1
74	JDP20VS-TH74	Switch Plate		1
75	TS-1532052	Phillips Pan Hd Machine Screw	M4x16	2
76	JDP20VS-TH76	Label Fwd/Rev		1
77	JDP20VS-TH77	Label Cover		1
78	JDP20VS-TH78	Knob		1
79	JDP20VS-TH79	Connection Cord		1
80	JDP20VS-TH80	Power Cord	.12AWG x3C 600V 105°C	1
81	JDP20VS-TH81	Power Cable Terminal Box		1
	JDP20VS-WL	Work Light (not shown)	input 110V	1
	LM000265	ID/Warning Label, JDP-20VS-1 (not shown)		1
	LM000266	ID/Warning Label, JDP-20VS-3 (not shown)		1
	JET-113	JET Logo (not shown)	113x47mm	1

### 13.3.1 Spindle Components (All Models) – Exploded View

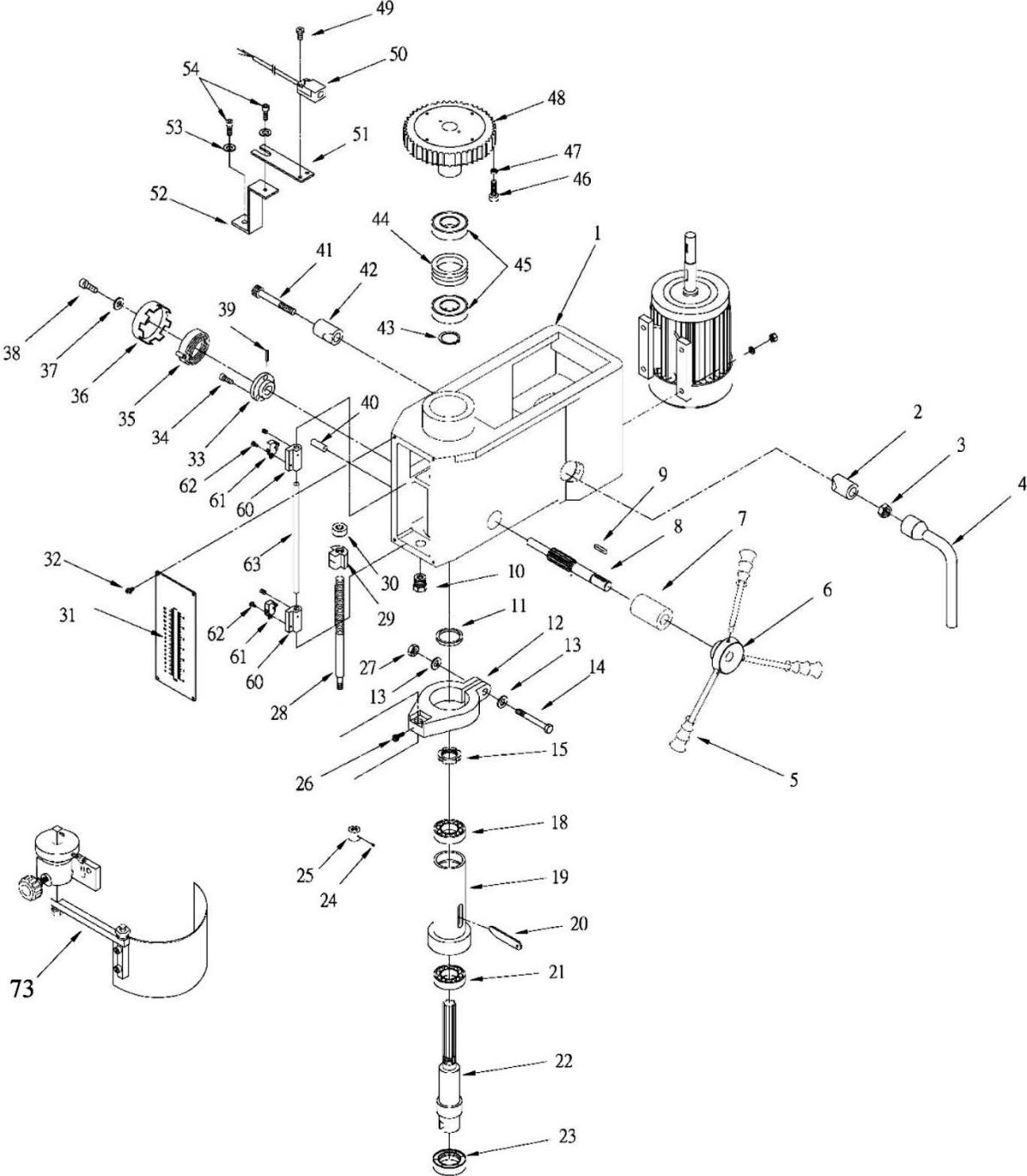

### 13.3.2 Spindle Components (All Models) – Parts List

Index No.	Part No.	Description	Size	Qty
1	JDP20VS-HD	Head Body for JDP20VS series		1
2	5510320	Rear Cam Lock		2
3	5510250	Hex Nut		1
4	5510251	Hex Head Wrench		1
5	5510286-RHA	Rubber Handle Assembly		3
6	J-5510285G	Hub		1
7	JDP20VS-LH07	Feed Shaft Seat		1
8	JDP20VS-LH08	Feed Shaft		1
9	5510282	Key	6x6x20	1
10	5510258	Set screw		1
11	5513770	Rubber Washer		1
12	J-5513771G	Quill Band		1
13	TS-0680021	Flat Washer	1/4"	2
14	5517380	Hex Screw	1/4"x2-1/2"	1
15	5510258	Lock Nut		1
18	BB-30206	Ball Bearing	30206	1
19	5510268	Quill		1
20	5513774	Drift Pin		1
21	BB-30207	Ball Bearing	30207	1
22	5510270	Spindle	MT3 / MT4	1
23	5510271	Oil Seal	45x72x8	1
24	TS-1523011	Set screw	M6	2
25	5510276	Retainer		1
26	JDP20VS-LH26	Set Screw	1/4"	1
27	TS-0561011	Hex Nut	1/4"	1
28	5510273	Depth Rod		1
29	JDP20VS-LH29	Depth Scale Bracket		1
30	5510272	Nut		1
31	5510278	Depth Scale		1
32	5510279	Screw	3/16"x5/16"	4
33	5510266	Spring Seat		1
34	5510265	Screw	3/16"x5/16"	3
35	5510263	Return Spring		1
36	5510263	Container (includes #35)		1
37	TS-0680021	Washer	1/4"	1
38	5510261	Set Knob	1/4"	1
39	5510267	Spring Pin		1
40	5510259	Roll Pin		1
41	JDP20VS-LH41	Hex. Shoulder Bolt		1
42	JDP20VS-LH42	Bushing		1
43	5510256	C-Ring	S45	1
44	5510255	Spacer		1
45	BB-6009ZZ	Ball Bearing	6009zz	2
46	F004766	Hex. Socket Cap Screw	#10-24x1"	1
47	TS-0560071	Hex Nut	#10-24	1
48	JDP20VS-LH48	Spindle Pulley	8Mx62T	1
49	TS-2244202	Screw	M4x20	1
50	5513515	Sensor		1
51	5517383	Sensor Support		1
52	JDP20VS-LH52	Sensor Bracket		1
53	TS-0680031	Washer	5/16"	2
54	TS-1504041	Hex. Socket Cap Screw	M8x20	2
60	JDP20VST-60	Micro switch bracket		2
61	JDP20VST-61	Micro Switch		2
62	JDP20VST-62	Screw	M3x16	4
63	JDP20VST-63	Micro Switch Support Rod		1
73	32106A	Safety Shield Assembly (for all models)		1

### 13.4.1 Safety Shield Assembly (All Models) – Exploded View

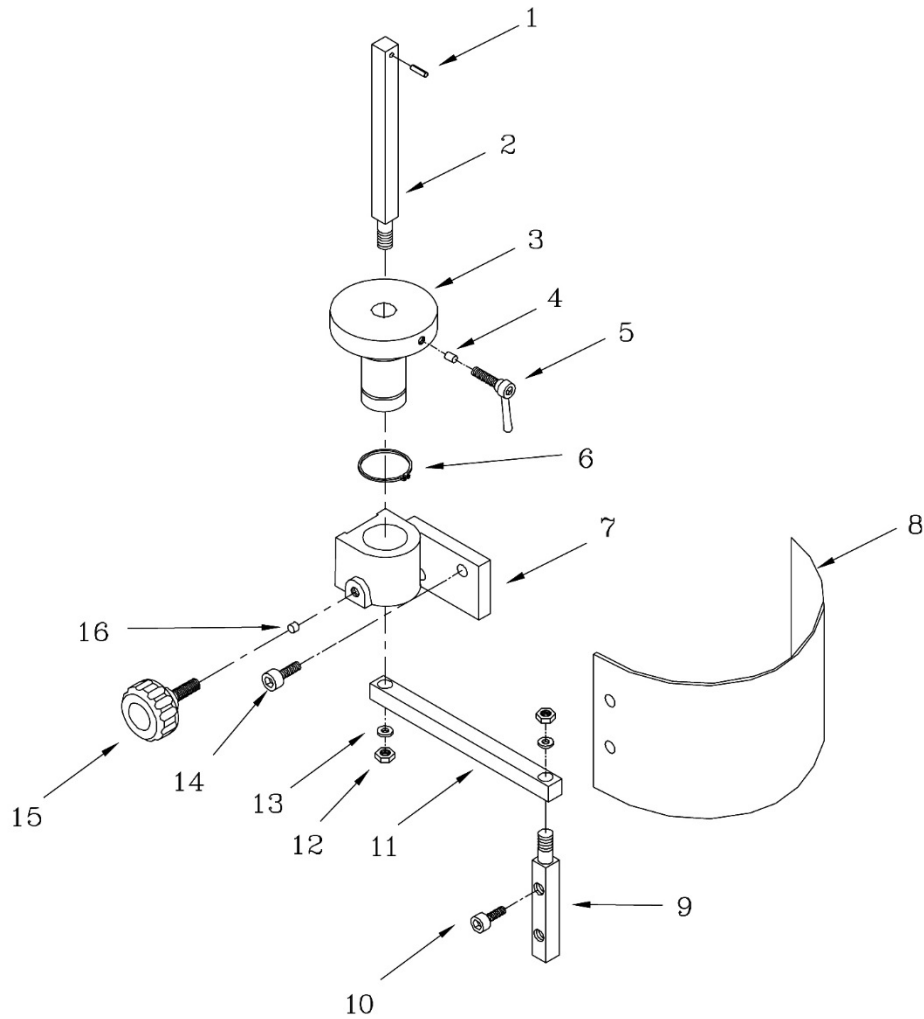

### 13.4.2 Safety Shield Assembly (All Models) – Parts List

Index No.	Part No.	Description	Size	Qty
	32106A	Safety Shield Assembly (#1 thru 16)		1
1	6293347	Spring Pin	3x16	1
2	32106A-2	Support Bracket Bar		1
3	32106A-3	Bushing		1
4	32106A-4	Spacer		1
5	32106A-5	Lock Handle	M6x20	1
6	32106A-6	C-Clip	S30	1
7	32106A-7	Bracket		1
8	32106A-8	Safety Shield	530x210mm	1
9	32106A-9	Lower Bracket Bar		1
10	TS-1504021	Hex Socket Head Cap Screw	M8x12	1
11	32106A-11	Support Arm		1
12	TS-0640091	Hex Nut	3/8"	1
13	TS-0720091	Spring Washer	3/8"	1
14	TS-1504041	Hex Socket Head Cap Screw	M8x20	1
15	32106A-16	Lock Bolt with Knob	M8	1
16	32106A-17	Spacer		1

### 13.5.1 Table and Base Assembly (All Models) – Exploded View

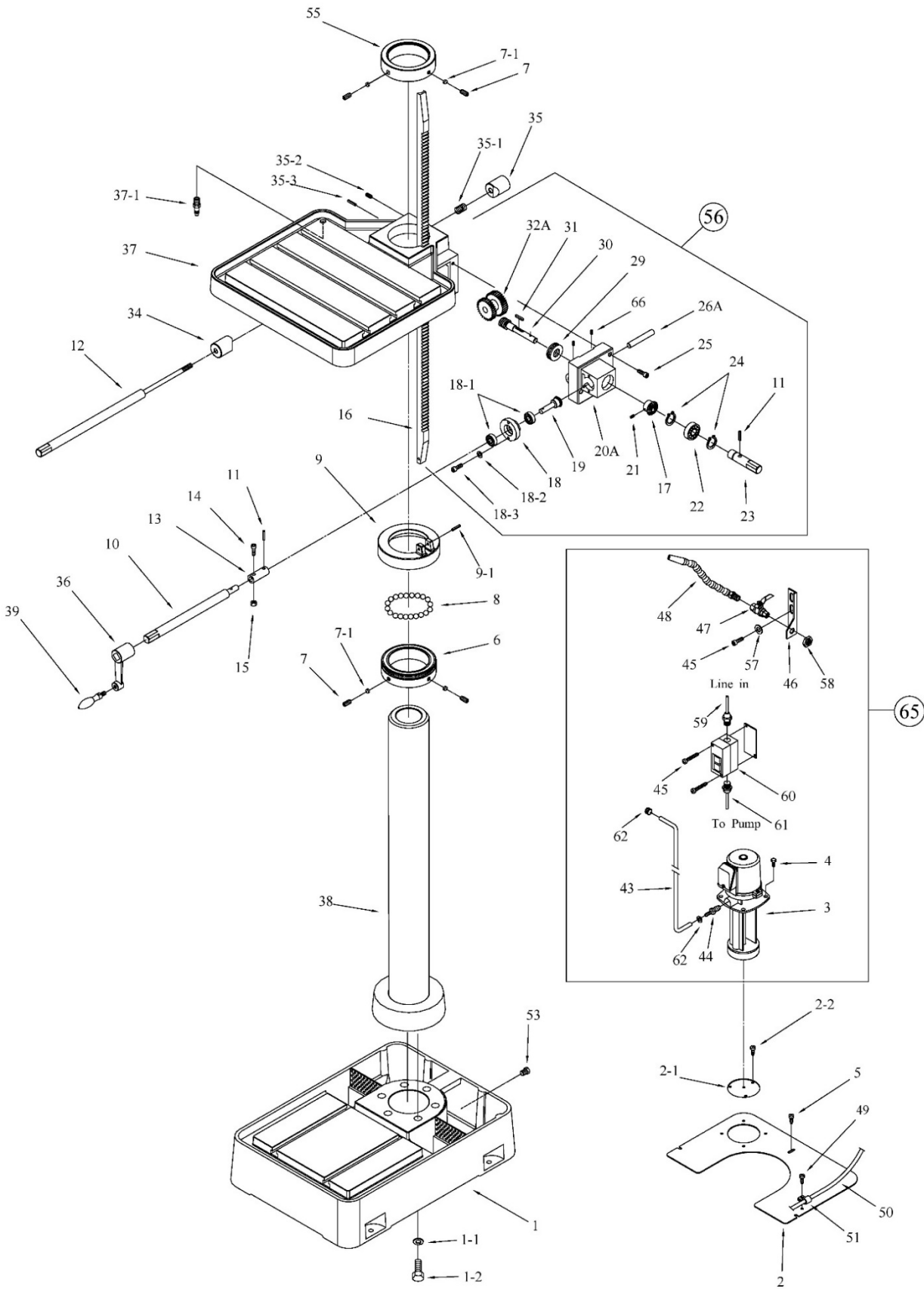



### 13.5.2 Table and Base Assembly (All Models) – Parts List

Index No.	Part No.	Description	Size	Qty
1	J-5510288A	Base		1
1-1	TS-0720111	Lock Washer	1/2"	6
1-2	TS-0070031	Hex Cap Screw	1/2" x 1-1/2"	6
2	J-5510289	Coolant Cover Plate		1
2-1	20EVS-C2-1	Small Cover		1
2-2	20EVS-C4	Screw w/Washer	1/4"	3
3	5510456	Coolant Pump	115V/230V, 1P	1
	5512103	Coolant Pump	220/440V, 3P	1
4	TS-1482011	Hex Bolt	M6x10	4
5	5517388	Pan Head Screw		3
6	5510293A	Ball Seat		1
7	5510294	Set Screw	3/8"	4
7-1	5517389	Brass Block		4
8	5510295	Ball Bearing	3/8"	38
9	J-5510296A	Lock Ring		1
9-1	5517390	Pin	M4	1
10	5516859	Table Raiser Shaft		1
11	5510298	Spring Pin	4x20mm	1
12	5516858	Table Clamp Shaft		1
13	5516860	Table Raiser Coupling		1
14	5510300	Socket Head Screw		1
15	TS-0561011	Nut	1/4"	1
16	5510302	Rack		1
17	5514663	Large Bevel Gear		1
18	5517391	Bearing Housing		1
18-1	BB-6202ZZ	Ball Bearing	6202ZZ	2
18-2	TS-0720071	Washer	1/4"	2
18-3	TS-1482041	Cap Screw	M6x20	2
19	5510304	Small Bevel Gear		2
20A	J-5510305A	Bracket Cover		1
21	TS-0267041	Set Screw	1/4"x3/8"	1
22	BB-6005ZZ	Ball Bearing	6005zz	1
23	5510308	Shaft		1
24	5510309	C-Ring	S25	2
25	TS-1504071	Hex Socket Cap Screw	M8x35	3
26A	5510311A	Shaft		1
29	BB-51102	Bearing	51102	1
30	5510315	Table Raise Worm		1
31	5510316	Key	4x4x20mm	1
32A	5510317A	Worm Gear Assembly		1
34	5510319	Front Cam Lock		1
35	5510320	Rear Cam Lock		1
35-1	5517396	Spring		1
35-2	TS-1523071	Set Screw	M6x25	1
35-3	5517398	Pin	5x25mm	2
36	J-5510321	Table Raise Crank		2
37	J-5510322	Table		1
37-1	5517399	Hose Coupler (Return)	1/2"	1
38	5510323A	Column		1
39	5510324	Table Raise Handle		1
43	5510328	Clear Vinyl Hose	3/8"	1
44	5510329	Hose Coupler (Supply)	3/8"	1
45	5512112	Socket Head Cap Screw	#10-32 x 1"	4
46	5510331	Mounting Bracket		1
47	5510332	Valve		1
48	5510333	Flexible Nozzle		1

Index No.	Part No.	Description	Size	Qty
49	5517400	Pan Head Screw		1
50	5517401	Clear Vinyl Hose	1/2"	1
51	5517402	Hose Clamp		1
53	5517404	Drain Plug	3/8 NPT	1
55	J-5517406	Rack Collar		1
56	5513932	Table Raiser Assembly		1
57	9057451	Flat Washer	#10	2
58	5517488	Hex Nut	1/2"	1
59	5517489	Power Cord		1
60	5517490	Switch Assembly		1
61	5517491	Pump Cord	1 Phase	1
	5517492	Pump Cord	3 Phase	1
62	5517493	Hose Clamp, Rad. Type		2
65	5512104	Coolant System Complete *	1/8 HP, 115/230V, 1 Phase	1
	5508071	Coolant System Complete *	1/8 HP, 230/460V, 3 Phase	1
66	TS-1522021	Socket Set Screw	M5x8	2
	J2221-SBCA	Support Bearing Collar Assembly (includes #6,7,7-1,8,9,9-1)		1

\* optional accessory