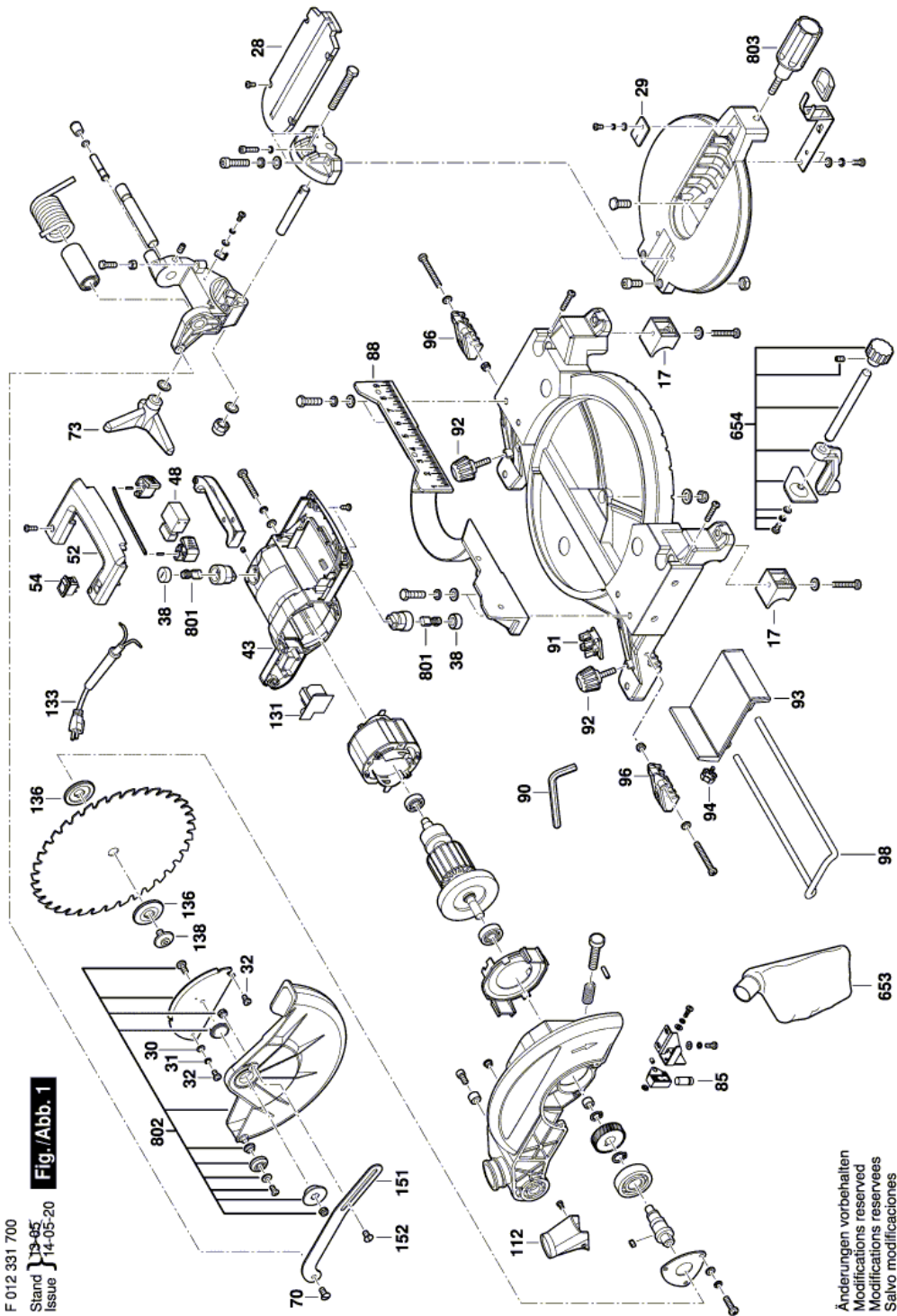

Table Mitre Saw - F 012 331 700 - 3317

Item	Part Number	Description	Illustration	Price	Quantity	Price Group
17	2 610 018 630	Clamp	1	-,-	2	-
28	2 610 018 642	Plate	1	-,-	1	-
29	2 610 018 643	Pointer	1	-,-	1	-
30	2 610 018 644	Plain Washer	1	-,-	2	-
31	2 610 018 645	Spring Washer	1	-,-	6	-
32	2 610 018 646	Screw	1	-,-	3	-
38	2 610 018 652	Protective Cap	1	-,-	2	-
43	2 610 018 657	Housing	1	-,-	1	-
48	2 610 018 662	Switch	1	-,-	1	-
52	2 610 018 762	Handle Cover	1	-,-	1	-
54	2 610 018 763	Switch	1	-,-	1	-
70	2 610 018 683	Screw	1	-,-	1	-
73	2 610 018 686	Knob	1	-,-	1	-
85	2 610 018 768	Laser module	1	-,-	1	-
88	2 610 018 693	Mitre Fence	1	-,-	1	-
90	2 610 018 695	Disassembly Tool	1	-,-	1	-
91	2 610 018 696	Holder	1	-,-	1	-
92	2 610 018 697	Knob	1	-,-	2	-
93	2 610 018 749	Cast Supporting Table	1	-,-	1	-
94	2 610 018 753	Knob	1	-,-	1	-
96	2 610 018 699	Clamp	1	-,-	2	-
98	2 610 018 752	Extension Tube	1	-,-	2	-
112	2 610 018 714	Dust Separator	1	-,-	1	-
131	2 610 018 771	Transformer	1	-,-	1	-
133	2 610 018 730	Cord	1	-,-	1	-
136	2 610 018 733	Special Washer	1	-,-	1	-
138	2 610 018 734	Locking Bolt	1	-,-	1	-
151	2 610 018 743	Rod	1	-,-	1	-
152	2 610 007 827	Screw	1	-,-	1	-
653	2 610 017 172	Dust Bag	1	-,-	1	-
654	2 610 017 173	Clamp	1	-,-	1	-
801	2 610 018 664	Brush	1	-,-	1	-
802	2 610 018 720	Lower guard	1	-,-	1	-

Item	Part Number	Description	Illustration	Price	Quantity	Price Group
803	2 610 018 731	Handle	1	-,-	1	-

Illustration - Type E



Information subject to change without further notice.