

22.11.2013 |

Slide Mitre Saw - F 012 330 200 - 3302

SKIL

Item	Part Number	Description	Illustration	Price	Quantity	Price Group
2	2 610 958 905	Clamp	1	\$ 1.29	4	12
3	2 610 958 906	Knob	1	\$ 4.10	4	18
4	2 610 958 969	Spring	1	\$ 1.07	4	11
9	2 610 031 374	Adjustable Foot	1	\$ 20.95	1	32
10	2 610 031 375	Knob	1	\$ 2.42	1	15
16	2 610 031 376	Rubber Pad	1	\$ 1.90	3	14
24	2 610 958 965	board	1	\$ 3.55	1	17
25	2 610 958 967	Knob	1	\$ 5.45	2	20
26	2 610 958 968	Carrying Bolt	1	\$ 1.07	2	11
27	2 610 958 966	board	1	\$ 3.55	1	17
29	2 610 958 964	Knob	1	\$ 4.10	2	18
805	2 610 031 379	Mounting Bracket	1	\$ 1.60	2	13
807	2 610 958 972	Fastening parts kit	1	\$ 2.77	4	16
808	2 610 958 971	Support	1	\$ 14.15	2	28

Product information Slide Mitre Saw - F 012 330 200 - 3302

Product No	F 012 330 200
Description	266,914; Slide Mitre Saw
DIN-Text	
ID_Text_Ext	0
Trading_Description	3302
Voltage_1	120 V
ID_Country_Product	USA

Illustration - Type E

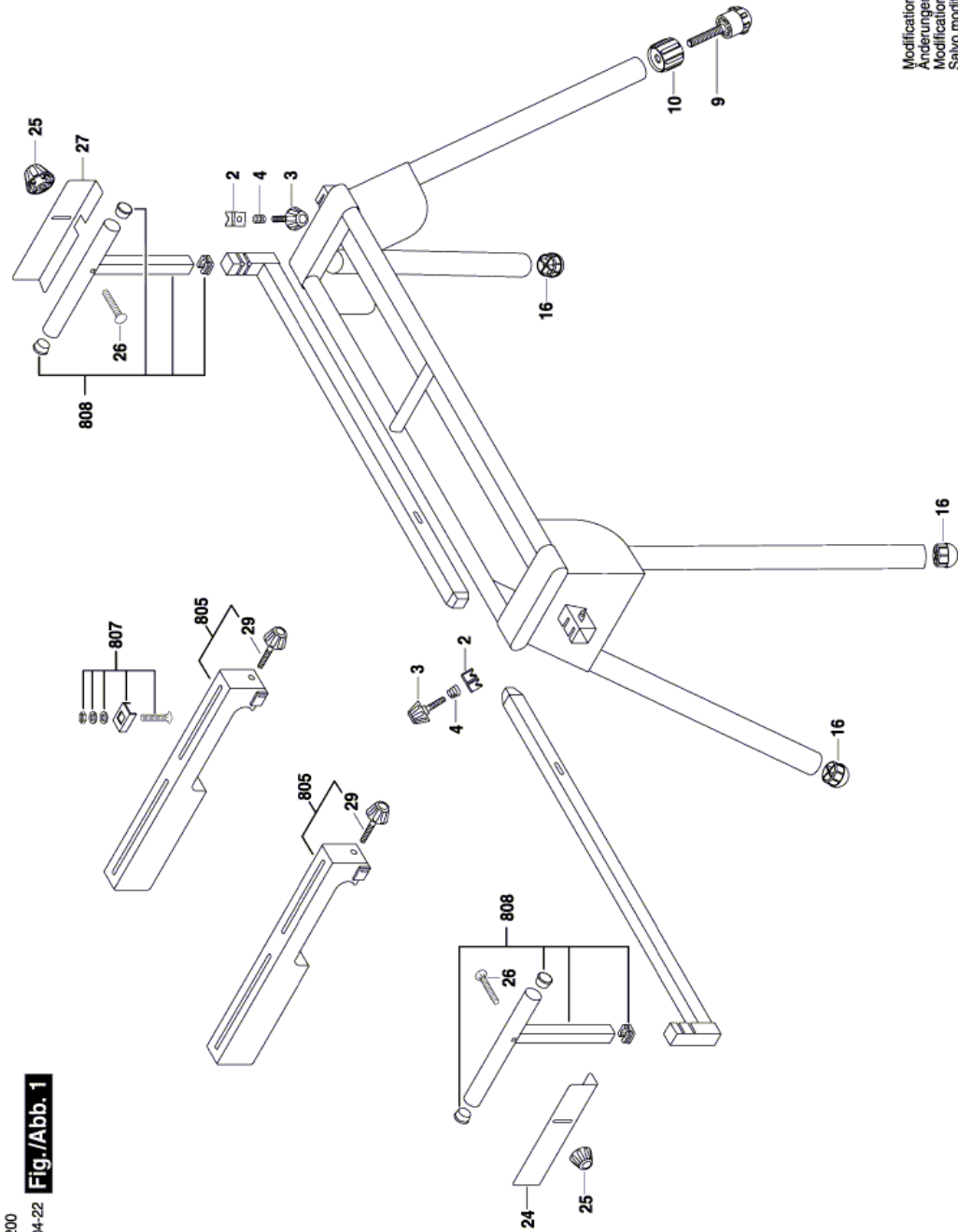

F 012 330 200
Issue } 13-04-22
Stand } **Fig./Abb. 1**

Modifications reserved
Änderungen vorbehalten
Modificacions reserwadas
Salvo modificaciones