

CRAFTSMAN DRILL PRESS – MODEL NO. 219140

FIGURE A

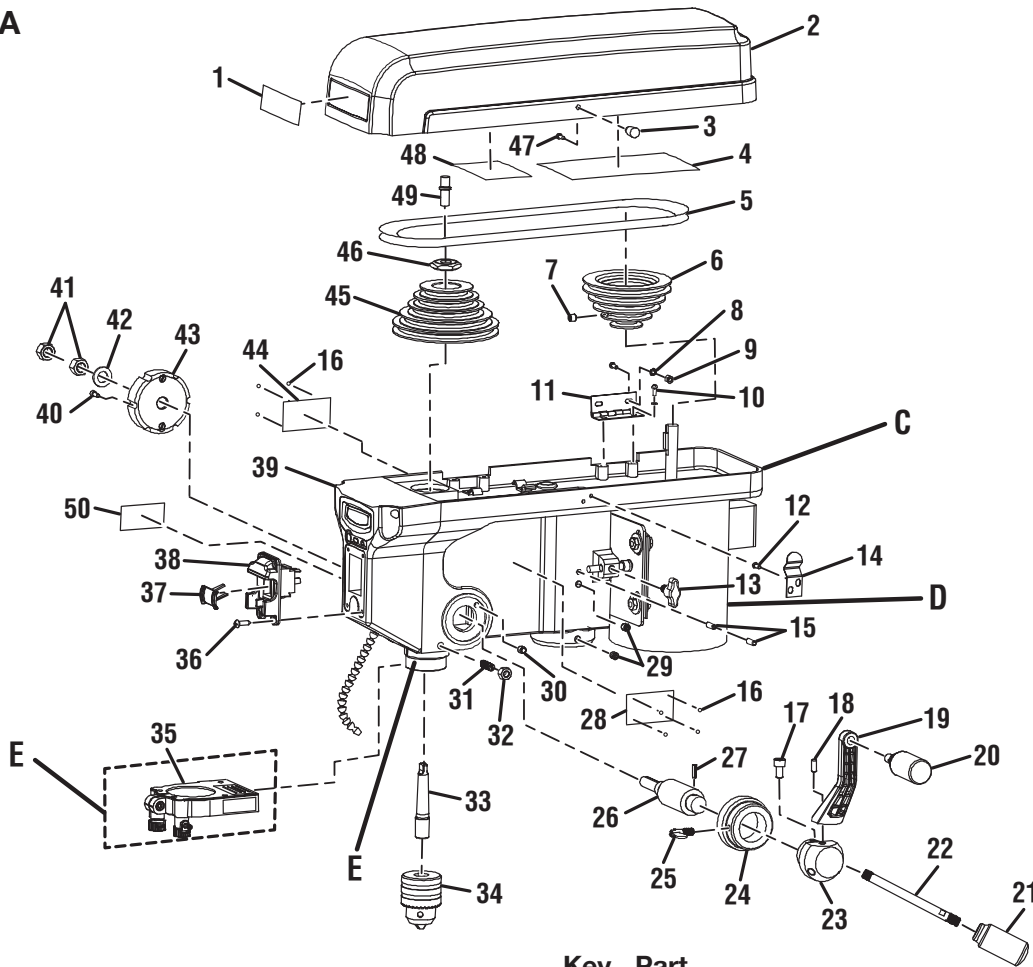

Key Part No.	Part Number	Description	Qty.	Key Part No.	Part Number	Description	Qty.
1	089140301146	LOGO LABEL	1	27	089140301099	ROLL PIN (D5 X 16 mm).....	1
2	089140301001	COVER	1	28	089140301150	WARNING LABEL.....	1
3	089140301002	COVER BUTTON.....	1	29	089140301021	*SCREW (M8 X 8 mm, HEX SOCKET HD.)	2
4	089140301145	SPEED LABEL.....	1	30	089140301100	ROLL PIN.....	1
5	089140301004	DRIVE BELT	1	31	089140301083	THREADED PIN.....	1
6	089140301005	MOTOR PULLEY	1	32	089140301084	*HEX NUT (M8)	7
7	089140301012	*SET SCREW (M6 X 10 mm).....	1	33	089140301067	ARBOR	1
8	089140301010	*EXTERNAL LOCK WASHER.....	8	34	089140301152	CHUCK	1
9	089140301009	*HEX NUT (M4)	4	35	089140301162	LASER ASSEMBLY.....	1
10	089140301008	*SCREW (M4 X 10 mm, PAN HD.) ..	.8	36	089140301042	*SCREW (M4.2 X 16 mm)	4
11	089140301011	COVER HINGE	2	37	089140301043	SWITCH KEY	1
12	089140301106	*SCREW (M4 X 6 mm, PAN HD.)	2	38	089140301044	SWITCH (HY18).....	1
13	089140301102	TENSION KNOB	1	39	089140301165	HEAD ASSEMBLY	1
14	089140301107	COVER LATCH	1	40	089140301031	*SCREW (M4 X 10 mm HEX SOCKET CAP HD.).....	1
15	089140301101	ROLL PIN (D6 X 16 mm).....	2	41	089140301030	*HEX NUT (1/2 in.)	2
16	089140301168	RIVETS	8	42	089140301029	*WASHER (M12)	1
17	089140301098	*SCREW (M8 X 15 mm, HEX SOCKET CAP HD.).....	1	43	089140301167	HANDLE RECOIL ASSEMBLY.....	1
18	089140301097	PIN (D6 x 12 mm)	1	44	089140301147	DATA LABEL	1
19	089140301096	FEED CRANK	1	45	089140301013	SPINDLE PULLEY	1
20	089140301095	KNOB ASSEMBLY.....	1	46	089140301014	SPECIAL PULLEY NUT	1
21	089140301089	KNOB	2	47	089140301003	*SCREW (M4.2 X 16 mm, PAN HD.).....	1
22	089140301088	FEED HANDLE	2	48	089140301169	FRACTION LABEL.....	1
23	089140301094	HUB.....	1	49	089140301170	SLEEVE	1
24	089140301087	DEPTH GAUGE	1	50	089140301907	WORKLIGHT LABEL	1
25	089140301086	DEPTH LOCK SCREW	1				
26	089140301085	SHAFT PINION	1				

* Standard Hardware Item – May Be Purchased Locally

CRAFTSMAN DRILL PRESS – MODEL NO. 219140

FIGURE B

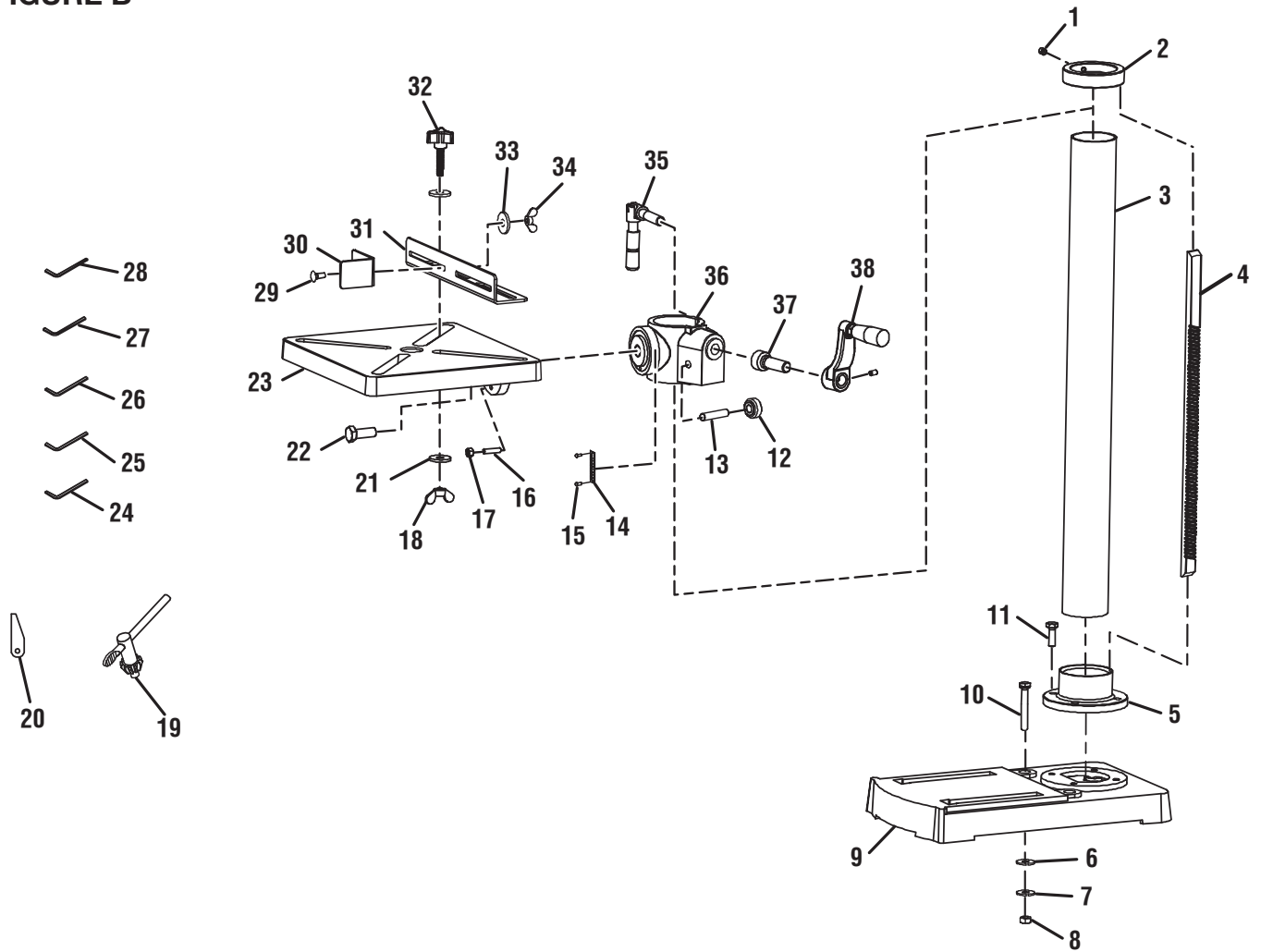

Key Part No.	Part Number	Description	Qty.	Key Part No.	Part Number	Description	Qty.
1	089140301092	SET SCREW (M6 X 10 mm).....	2	20	089140301154	CHUCK TOOL	1
2	089140301093	COLUMN COLLAR.....	1	21	089140301120	*WASHER (M9 X M28 X 3T).....	4
3	089140301090	COLUMN.....	1	22	089140301129	HEX BOLT.....	1
4	089140301091	GEAR RACK	1	23	089140301127	TABLE	1
5	089140301142	BASE COLLAR	1	24	089140301155	*HEX KEY 2.5 mm.....	1
6	089140301139	*WASHER (M8.4 X M16 X 1.6T).....	2	25	089140301156	*HEX KEY 3 mm.....	1
7	089140301138	* LOCK WASHER (D8)	2	26	089140301157	*HEX KEY 4 mm.....	1
8	089140301084	*HEX NUT (M8)	2	27	089140301158	*HEX KEY 5 mm.....	1
9	089140301141	BASE	1	28	089140301159	*HEX KEY 6 mm.....	1
10	089140301140	*MOUNTING BOLT (M8 X 125 mm, HEX HD.)	2	29	089140301125	*SCREW (M6 X 16 mm)	1
11	089140301136	*BOLT (M8 x 25 mm, HEX HD.)	4	30	089140301124	FENCE BRACKET	1
12	089140301135	GEAR.....	1	31	089140301126	ADJUSTABLE FENCE.....	1
13	089140301134	GEAR SHAFT	1	32	089140301121	FENCE SCREW	2
14	089140301133	BEVEL SCALE	1	33	089140301123	*WASHER (D6).....	1
15	089140301132	*SCREW (M2 X 5 mm)	2	34	089140301122	*WING NUT (M6).....	1
16	089140301131	THREADED PIN.....	1	35	089140301119	TABLE LOCK HANDLE.....	1
17	089140301130	*HEX NUT (1/4-20).....	1	36	089140301118	SUPPORT.....	1
18	089140301128	*WING NUT (M8).....	2	37	089140301117	WORM GEAR	1
19	089140301153	CHUCK KEY (1/2 in.).....	1	38	089140301116	TABLE ADJUSTMENT HANDLE	1
					983000830	OPERATOR'S MANUAL	
					03-19-07		
					(Rev:03)		

* Standard Hardware Item – May Be Purchased Locally

CRAFTSMAN DRILL PRESS – MODEL NO. 219140

FIGURE C

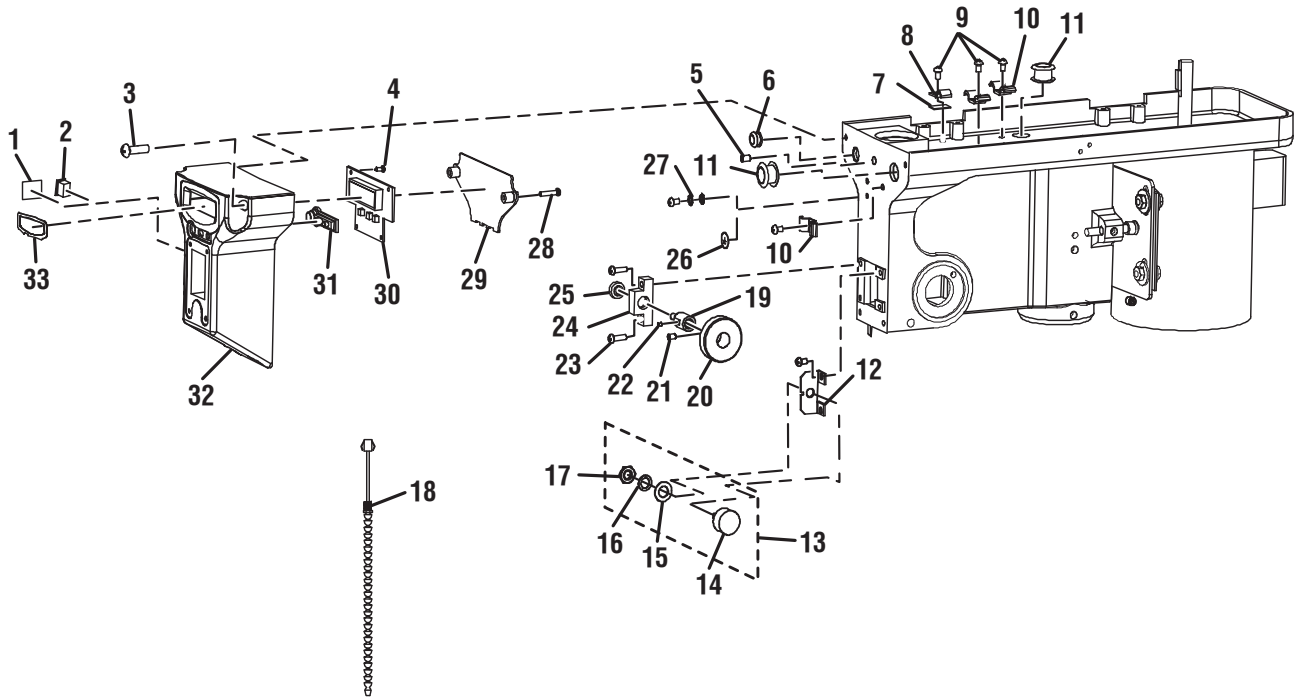

Key Part No.	Part Number	Description	Qty.	Key Part No.	Part Number	Description	Qty.
1	089140301148	LED WARNING LABEL.....	1	17	089140301053	*HEX NUT (M9)	1
2	089140301039	LED SWITCH (HY17-6 125-250 8/4A).....	1	18	089140301045	LED LIGHT ASSEMBLY.....	1
3	089140301038	*SCREW (M5 X 14 mm, PAN HD.	4	19	089140301051	SHAFT	1
4	089140301034	*SCREW (M2.9 X 9.5 mm, COUNTERSINK HD.).....	4	20	089140301052	DEPTH DISPLAY GEAR.....	1
5	089140301021	*SCREW (M8 X 8 mm, HEX SOCKET HD.)	1	21	089140301050	*SCREW (M5 X 8 mm, HEX SOCKET HD.)	1
6	089140301020	RUBBER GROMMET	1	22	089140301049	*SCREW (M4 X 5 mm, HEX SOCKET HD.)	1
7	089140301019	SPONGE.....	1	23	089140301046	*SCREW (M5 X 16 mm, PAN HD.).....	2
8	089140301018	SINGLE LINE CLAMP PLATE	1	24	089140301048	LEFT BRACKET.....	1
9	089140301016	*SCREW (M5 X 8 mm, PAN HD.)	8	25	089140301047	BEARING.....	1
10	089140301017	DOUBLE LINE CLAMP PLATE	3	26	089140301024	GROUNDING LABEL	2
11	089140301015	RUBBER GROMMET	2	27	089140301022	EXTERNAL LOCK WASHER.....	4
12	089140301143	RIGHT BRACKET	1	28	089140301032	SCREW (M4 X 20 mm, PAN HD.)	2
13	089140301163	POTENTIOMETER ASSEMBLY	1	29	089140301033	COVER BOARD.....	1
14	089140301056	POTENTIOMETER (RV24YN)	1	30	089140301035	CIRCUIT BOARD.....	1
15	089140301055	*WASHER (M9 X 15 X .5T).....	1	31	089140301036	DISPLAY BUTTONS	1
16	089140301054	*LOCK WASHER (M9.6 X 15 X 1.6T)	1	32	089140301037	SWITCH BOX	1
				33	089140301041	LENS	1

* Standard Hardware Item – May Be Purchased Locally

CRAFTSMAN DRILL PRESS – MODEL NO. 219140

FIGURE D

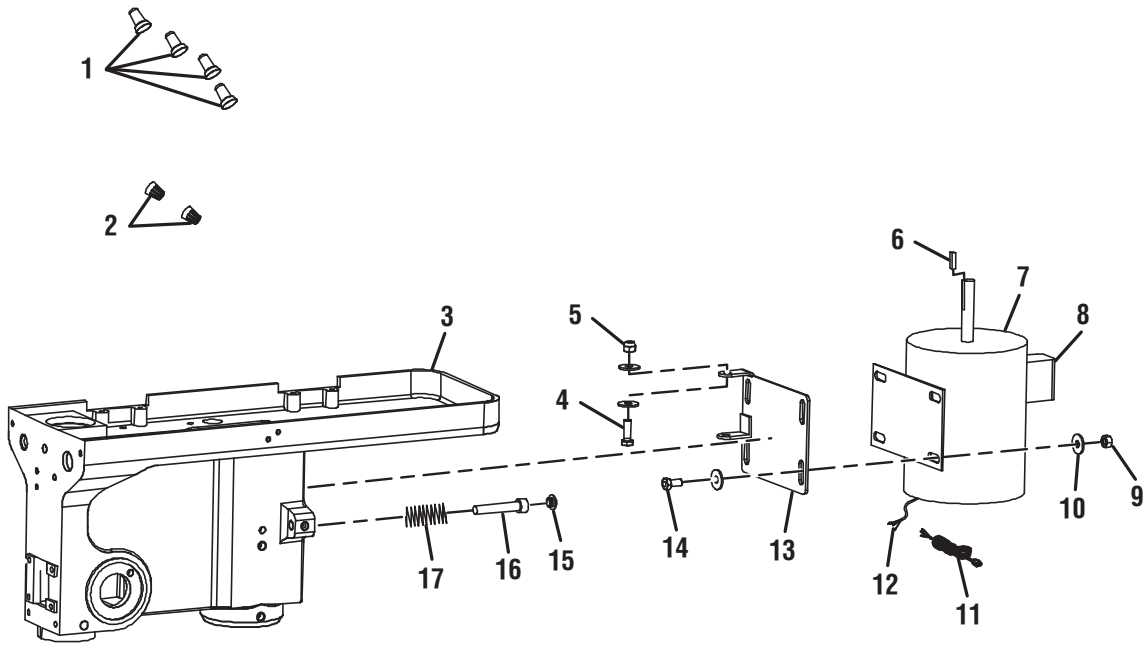

Key Part No.	Number	Description	Qty.	Key Part No.	Number	Description	Qty.
1	089140301023	SPLICE CONNECTORS	4	10	089140301109	*WASHER (M8.4 X 24 X 2T)	12
2	089140301040	*WIRE NUT	2	11	089140301115	POWER CORD	1
3	089140301006	HEAD STOCK.....	1	12	089140301114	MOTOR CORD	1
4	089140301108	*BOLT (M8 X 30 mm, HEX HD.)	2	13	089140301144	MOTOR BASE	1
5	089140301110	*HEX LOCK NUT (M8).....	2	14	089140301111	BOLT (M8 X 16 mm, HEX HD.)	4
6	089140301112	KEY (5 X 25 mm)	1	15	089140301105	RUBBER PLUG	1
7	089140301160	MOTOR ASSEMBLY.....	1	16	089140301104	SLIDE ROD.....	1
8	089140301161	CAPACITOR	1	17	089140301103	SPRING	1
9	089140301084	*HEX NUT ((M8)	4				

* Standard Hardware Item – May Be Purchased Locally

CRAFTSMAN DRILL PRESS – MODEL NO. 219140

FIGURE E

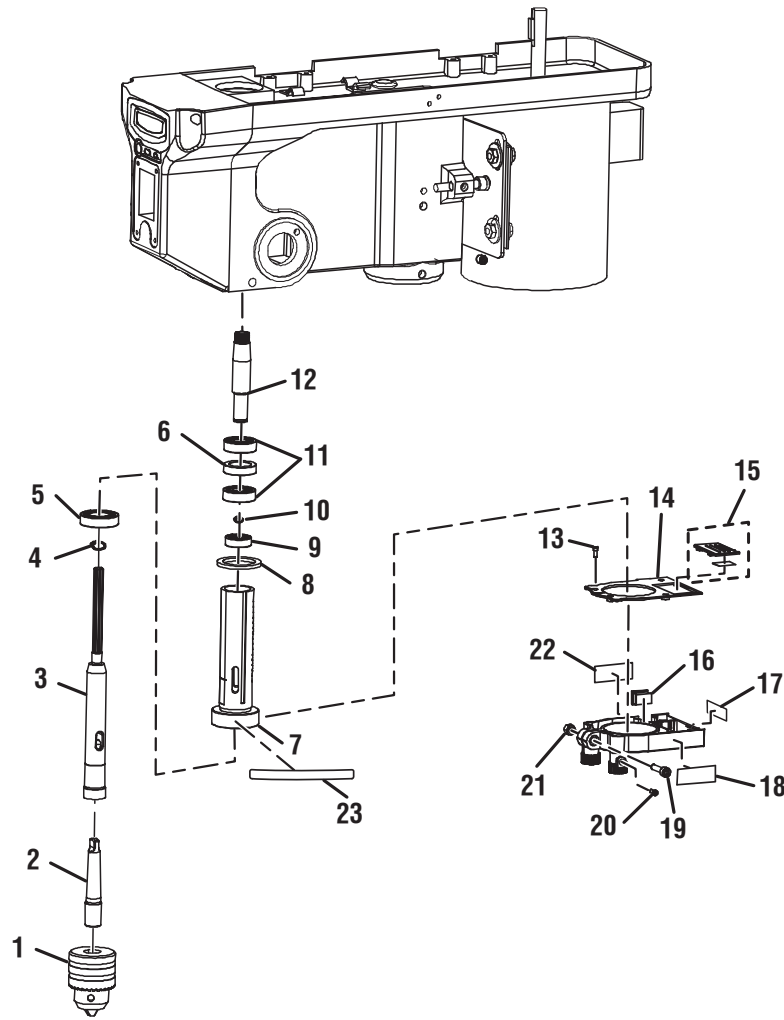

Key Part No.	Number	Description	Qty.	Key Part No.	Number	Description	Qty.
1	089140301152	CHUCK.....	1	14	089140301080	LASER BOX COVER.....	1
2	089140301067	ARBOR.....	1	15	089140301082	BATTERY COVER.....	1
3	089140301066	SPINDLE.....	1	16	089140301075	LASER SWITCH (HY17-4).....	1
4	089140301065	RETAINING RING.....	1	17	089140301166	CFR LABEL.....	1
5	089140301064	BALL BEARING.....	1	18	089140301149	WARNING LABEL (RIGHT).....	1
6	089140301059	SPACER.....	1	19	089140301071	*SCREW (M6 X 16 mm, HEX SOCKET HD.).....	1
7	089140301063	QUILL.....	1	20	089140301069	*SCREW (M3 X 5 mm, HEX SOCKET HD.).....	2
8	089140301062	GASKET QUILL.....	1	21	089140301079	*HEX NUT (M6).....	1
9	089140301061	BALL BEARING.....	1	22	089140301076	WARNING LABEL (LEFT).....	1
10	089140301060	RETAINING RING.....	1	23	089140301902	CAUTION LABEL.....	1
11	089140301058	BALL BEARING.....	2				
12	089140301057	SLEEVE.....	1				
13	089140301081	*SCREW (M3 X 8 mm, HEX SOCKET HD.).....	4				

* Standard Hardware Item – May Be Purchased Locally