

SFW08

Upholstery Stapler



Parts Reference Guide



Repair Kit

YK0397



*** Schematic drawings inside**

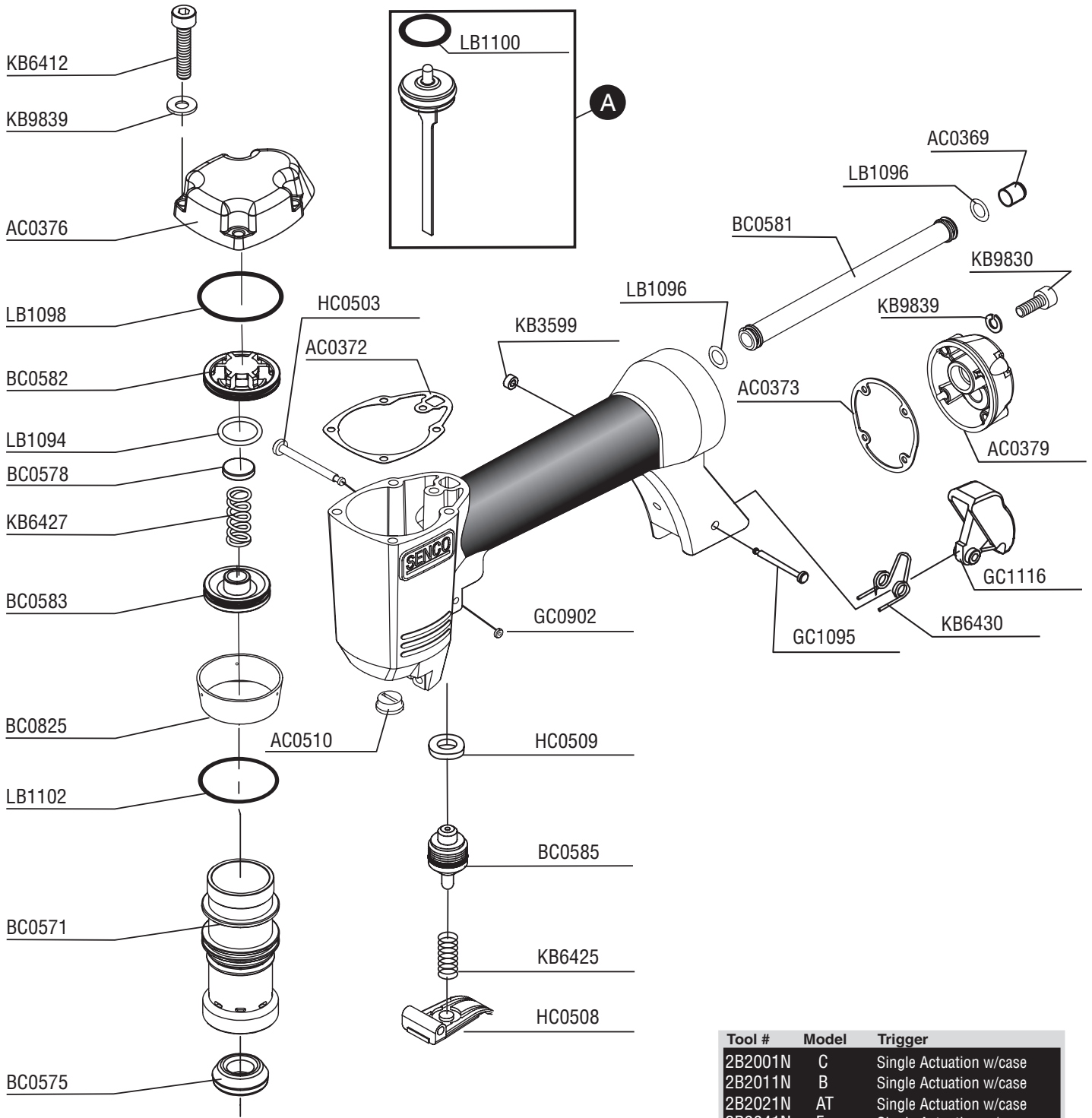

Tool #	Model	Trigger
2B2001N	C	Single Actuation w/case
2B2011N	B	Single Actuation w/case
2B2021N	AT	Single Actuation w/case
2B9041N	F	Single Actuation w/case
2B9071N	J	Single Actuation w/case

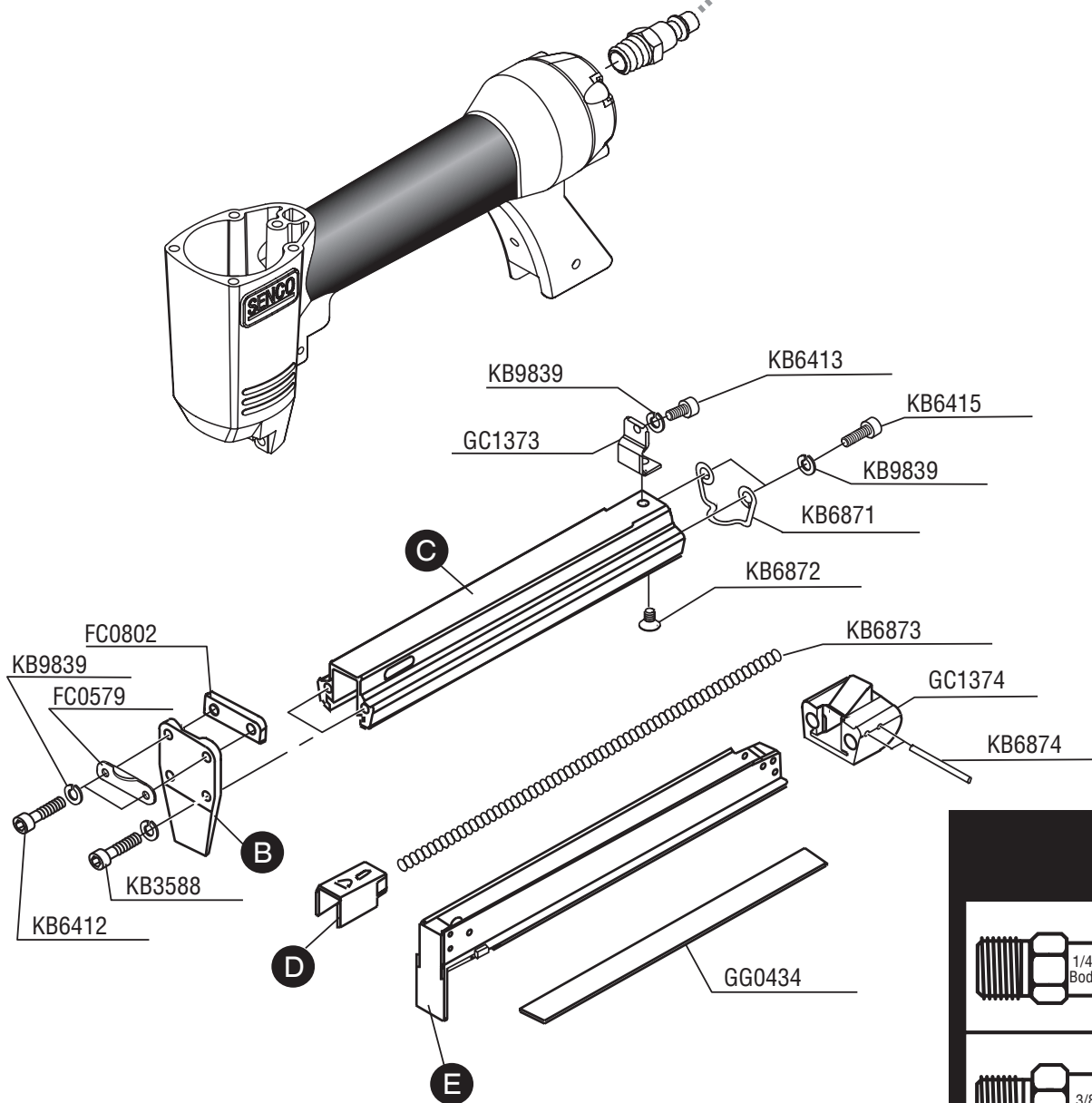

Tool #	A	B	C	D	E
2B2001N C- Wire	EA0252	FC0803	GC1375	GC1377	GA0576
2B2011N B- Wire	EA0253	FC0804	GC1376	GC1378	GA0577
2B2021N AT-wire	EA0254	FC0805	GC1376	GC1379	GA0578
2B9041N F- Wire	EA0306	FC0901	GC1526	GC1527	GA0700
2B9071N J- Wire	EA0307	FC0902	GC1526	GC1527	GA0700

Available Plugs (Not Included with Tool)

- PC0479** ✓
1/4" Body
Ind. Interchange 1/4" NPT
- PC0486**
3/8" Body
Ind. Interchange 1/4" NPT
- PC0468** ✓
1/4" Body
Tru-Flate 1/4" NPT
- PC0474**
3/8" Body
Tru-Flate 1/4" NPT

✓ **Recommended Plugs**
Plugs shown smaller than actual size

SFW08 Upholstery Stapler

REPLACEMENT PARTS LIST • LISTA DE PARTES DE REPUESTO • ERSATSTEILE-LISTE • LISTE DE PIÈCES DE RECHANGE

PART NO.	DESCRIPTION	DESCRIPCIÓN	BESCHREIBUNG	DÉSIGNATION
AC0369	MUFFLER	SILENCIADOR	DÄMPFER	SILENCIEUX
AC0372	SEAL	SELLO	DICHTUNG	JOINT
AC0373	SEAL	SELLO	DICHTUNG	JOINT
AC0376	CAP	TAPA	KAPPE	BOUCHON
AC0379	COVER	CUBIERTA	ABDECKUNG	COUVERCLE
AC0510	BUSHING	CASQUILLO	HÜLSE	DOUILLE
BC0571	CYLINDER	CILINDRO	ZYLINDER	CYLINDRE
BC0575	STOP	TOPE	PUFFER	ARRÊT
BC0578	SEAL	SELLO	DICHTUNG	JOINT
BC0581	TUBE	TUBO	RÖHRE	TUBE
BC0582	VALVE	VÁLVULA	VENTIL	VALVE
BC0583	VALVE	VÁLVULA	VENTIL	VALVE
BC0585	VALVE	VÁLVULA	VENTIL	VALVE
BC0825	RETAINER	JUNTA TÓRICA	SICHERUNGSRING	RETENUE
EA0252	PISTON ASSEMBLY (C)	ASAMBLE DE PISTON	KOLBEN-ZUSAMMENBAU	ENSEMBLE PISTON -COUTEAU
EA0253	PISTON ASSEMBLY (B)	ASAMBLE DE PISTON	KOLBEN-ZUSAMMENBAU	ENSEMBLE PISTON -COUTEAU
EA0254	PISTON ASSEMBLY (AT)	ASAMBLE DE PISTON	KOLBEN-ZUSAMMENBAU	ENSEMBLE PISTON -COUTEAU
EA0306	PISTON ASSEMBLY (F)	ASAMBLE DE PISTON	KOLBEN-ZUSAMMENBAU	ENSEMBLE PISTON -COUTEAU
EA0307	PISTON ASSEMBLY (J)	ASAMBLE DE PISTON	KOLBEN-ZUSAMMENBAU	ENSEMBLE PISTON -COUTEAU
FC0579	PLATE	PLACA	PLATTE	PLAQUE
FC0802	PLATE	PLACA	PLATTE	PLAQUE
FC0803	PLATE (C)	PLACA	PLATTE	PLAQUE
FC0804	PLATE (B)	PLACA	PLATTE	PLAQUE
FC0805	PLATE (AT)	PLACA	PLATTE	PLAQUE
FC0901	PLATE (F)	PLACA	PLATTE	PLAQUE
FC0902	PLATE (J)	PLACA	PLATTE	PLAQUE
GA0576	MAGAZINE (C)(EURO)	CARGADOR	MAGAZIN	MAGASIN
GA0577	MAGAZINE (B)(EURO)	CARGADOR	MAGAZIN	MAGASIN
GA0578	MAGAZINE (AT)(EURO)	CARGADOR	MAGAZIN	MAGASIN
GA0700	MAGAZINE (F&J)	CARGADOR	MAGAZIN	MAGASIN
GC0902	RETAINER	JUNTA TÓRICA	SICHERUNGSRING	RETENUE
GC1095	PIN	PASADOR	STIFT	GOUPILLE
GC1116	LATCH	UÑETA	VERSCHLUSS	DOIGT DE RETENUE
GC1374	PLATE	PLACA	PLATTE	PLAQUE
GC1373	BRACKET	SOPORTE	HALTERUNG	CAVALIER
GC1375	MAGAZINE (C)	CARGADOR	MAGAZIN	MAGASIN
GC1376	MAGAZINE (B&AT)	CARGADOR	MAGAZIN	MAGASIN
GC1377	FEEDER SHOE (C)	ALIMENTADOR	KLAMMERSCHIEBER	POUSSOIR
GC1378	FEEDER SHOE (B)	ALIMENTADOR	KLAMMERSCHIEBER	POUSSOIR
GC1379	FEEDER SHOE (AT)	ALIMENTADOR	KLAMMERSCHIEBER	POUSSOIR
GC1526	MAGAZINE (F&J)	CARGADOR	MAGAZIN	MAGASIN
GC1527	FEEDER SHOE (J&F)	ALIMENTADOR	KLAMMERSCHIEBER	POUSSOIR
GG0434	LABEL(EURO)	ETIQUETA	AUFKLEBER	ÉTIQUETTE
HC0503	PIN	PASADOR	STIFT	GOUPILLE
HC0508	TRIGGER	GATILLO	AUSLÖSER	GACHETTE
HC0509	SEAL	SELLO	DICHTUNG	JOINT
KB6412	SCREW	TORNILLO	SCHRAUBE	VIS
KB6413	SCREW	TORNILLO	SCHRAUBE	VIS
KB6415	SCREW	TORNILLO	SCHRAUBE	VIS
KB6425	SPRING	RESORTE	FEDER	RESSORT
KB6427	SPRING	RESORTE	FEDER	RESSORT
KB6430	SPRING	RESORTE	FEDER	RESSORT
KB6871	SPRING	RESORTE	FEDER	RESSORT
KB6872	SCREW	TORNILLO	SCHRAUBE	VIS
KB6873	SPRING	RESORTE	FEDER	RESSORT
KB6874	PIN	PASADOR	STIFT	GOUPILLE
KB9830	SCREW	TORNILLO	SCHRAUBE	VIS
KB9839	WASHER	ARANDELA	SCHIBE	RONDELLE
KB3588	SCREW	TORNILLO	SCHRAUBE	VIS
KB3599	RETAINER	JUNTA TÓRICA	SICHERUNGSRING	RETENUE
LB1094	SEAL	SELLO	DICHTUNG	JOINT
LB1096	SEAL	SELLO	DICHTUNG	JOINT
LB1098	SEAL	SELLO	DICHTUNG	JOINT
LB1100	SEAL	SELLO	DICHTUNG	JOINT
LB1102	SEAL	SELLO	DICHTUNG	JOINT