



SERVICE PARTS LIST

BULLETIN NO.
54-26-2610

SPECIFY CATALOG NO. AND SERIAL NO. WHEN ORDERING PARTS		REVISED BULLETIN	DATE
M18 FUEL™ 1/2" Square Impact Wrench			Nov. 2013
CATALOG NO.	2655B-20	STARTING SERIAL NO.	F03A
		WIRING INSTRUCTION SEE PAGE 2	

IMPORTANT NOTE: Gearcase end cap #25 is LEFT HAND THREAD!

As an aid to assembly, carefully lower the complete front end of tool (gearcase / impacting system) onto the gearcase end cap. Gently hand tighten front end assembly onto gearcase end cap. Be careful not to cross-thread! Once installed by hand, seat gearcase end cap with a good adjustable wrench using light pressure. Do not over tighten!

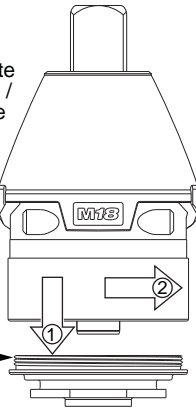

LEFT HAND THREAD

NOTE: Components of the impacting assembly (61) can drop out of the gearcase (57). Care must be taken to hold those elements in place when assembling onto the gearcase end cap (25).

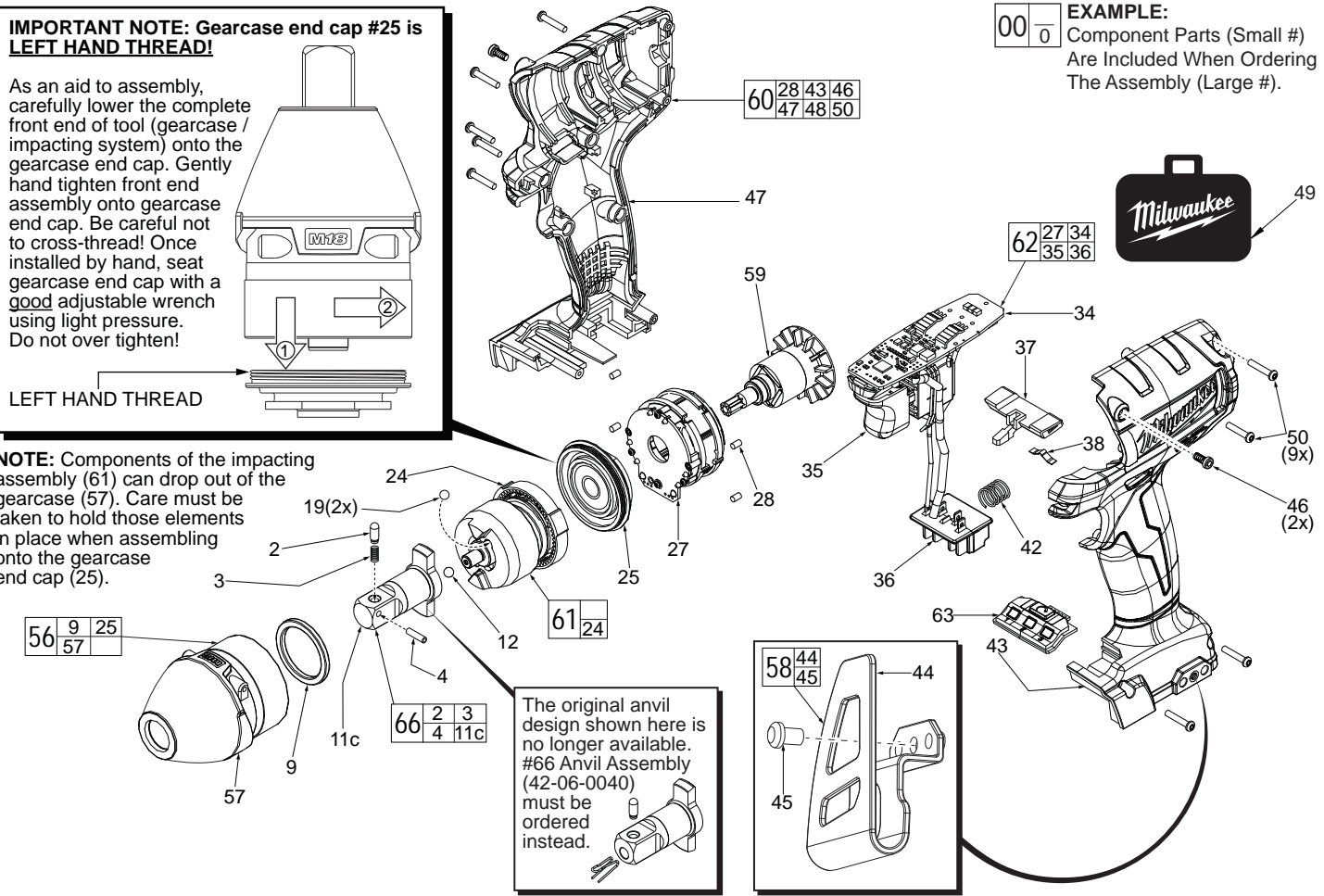

EXAMPLE:
Component Parts (Small #)
Are Included When Ordering
The Assembly (Large #).

FIG.	PART NO.	DESCRIPTION OF PART	NO. REQ.
2	44-60-1160	Detent Pin-Ball	(1)
3	40-50-0895	Detent Spring	(1)
4	44-60-0465	Pivot Pin	(1)
9	45-88-2653	Plastic Washer	(1)
11c	-----	1/2" Square Anvil	(1)
12	02-02-1300	5mm Steel Ball	(1)
19	02-02-0180	4.7mm Steel Ball	(2)
24	-----	Ring Gear	(1)
25	44-66-2653	Gearcase End Cap with Ball Bearing	(1)
27	-----	Stator Assembly	(1)
28	45-30-2653	Rubber Slug	(4)
34	-----	PCBA	(1)
35	23-66-2653	On-Off Switch	(1)
36	-----	Terminal Block Assembly	(1)
37	45-24-2653	Fwd/Rev Shuttle	(1)
38	40-50-1135	Spring	(1)
42	40-50-1090	Spring	(1)
43	-----	Left Handle Halve	(1)
44	-----	Belt Hook	(1)
45	06-82-0130	6-32 x 5/16" Pan Hd. T-15 Machine Scr	(1)
46	06-82-2653	M3.5 x 8mm Pan Hd. Plastite Screw	(2)
47	-----	Right Handle Halve	(1)
48	12-20-2653	Service Nameplate (Not Shown)	(1)
49	42-55-2653	Carrying Case	(1)
50	06-82-7236	4-20 x 5/8" Pan Hd. Plastite T-10 Scr	(9)
56	14-30-2656	Gearcase Assembly	(1)
57	28-50-2654	Front Gearcase	(1)

FIG.	PART NO.	DESCRIPTION OF PART	NO. REQ.
58	42-70-2653	Belt Clip Assembly	(1)
59	16-07-2654	Rotor Assembly	(1)
60	31-44-2653	Handle Assembly	(1)
61	14-30-0095	Impacting Assembly	(1)
62	14-20-2655	Electronics Assembly	(1)
63	45-24-2655	Speed Selector	(1)
66	42-06-0040	1/2" Sq. Anvil Assy. w/detent pin-ball	(1)

FIG. LUBRICATION
(Type 'J' Grease, No. 49-08-4220):

- 11c Lightly coat front washer surface of anvil (11c) with grease.
- 24,61 Lightly coat the I.D. of the ring gear (24) and the center of the planet gears of impacting assembly with grease.
- 57 Coat inside of bushing inside front gearcase with grease.
- 59 Coat pinion of rotor assembly (59) with grease.

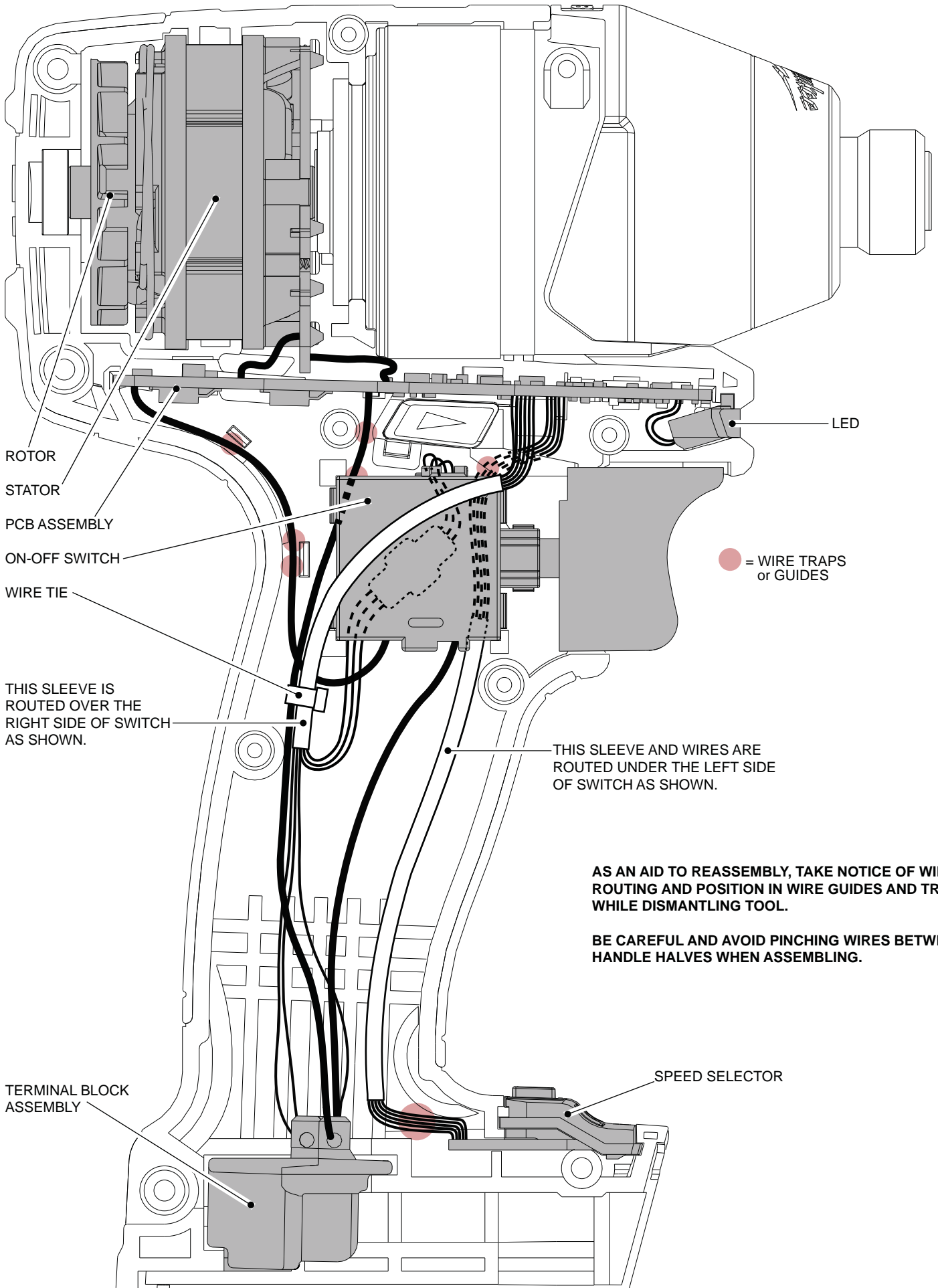

ROTOR

STATOR

PCB ASSEMBLY

ON-OFF SWITCH

WIRE TIE

THIS SLEEVE IS
ROUTED OVER THE
RIGHT SIDE OF SWITCH
AS SHOWN.

TERMINAL BLOCK
ASSEMBLY

LED

● = WIRE TRAPS
or GUIDES

THIS SLEEVE AND WIRES ARE
ROUTED UNDER THE LEFT SIDE
OF SWITCH AS SHOWN.

**AS AN AID TO REASSEMBLY, TAKE NOTICE OF WIRE
ROUTING AND POSITION IN WIRE GUIDES AND TRAPS
WHILE DISMANTLING TOOL.**

**BE CAREFUL AND AVOID PINCHING WIRES BETWEEN
HANDLE HALVES WHEN ASSEMBLING.**

SPEED SELECTOR