



# SERVICE PARTS LIST

**BULLETIN NO.**  
**54-40-2603**

SPECIFY CATALOG NO. AND SERIAL NO. WHEN ORDERING PARTS		REVISED BULLETIN 54-40-2602	DATE Aug. 2018
<b>CORDLESS 18V COMPACT BAND SAW</b>		WIRING INSTRUCTION <b>SEE PAGES 5, 6 and 7</b>	
CATALOG NO.	2629-20	STARTING SERIAL NO.	C14D

**EXAMPLE:**  
00 0 Component Parts (Small #)  
Are Included When Ordering  
The Assembly (Large #).

FIG.	PART NO.	DESCRIPTION OF PART	NO. REQ.
35	06-82-5574	10-24 x 7/8" Pan Hd. Tapt. T-25 Screw	(7)
36	06-82-0035	M5 Pan Hd. T-20 Screw	(3)
37	-----	Deck	(1)
39	-----	Brush Card	(1)
48	22-56-0150	Wire Nut (C1 & C2)	(2)

50	18-01-3015	Service Field	(1)
52	16-01-3091	Service Armature	(1)
53	05-78-0305	Switch Screw	(4)
54	45-88-1890	Spring Washer	(4)
55	06-82-5320	8-32 x 5/8" Pan Hd. Slit. Tapt. T-20 Screw	(3)
56	28-28-0060	Diaphragm	(1)
57	02-04-0645	Ball Bearing	(1)
58	-----	1st Gear	(1)
59	-----	Ball Bearing	(1)
60	-----	2nd Bevel Pinion	(1)
61	-----	Bevel/Spur Gear	(1)
62	-----	Needle Bearing	(2)
63	-----	Gearcase	(1)
64	02-04-0135	Ball Bearing	(1)
66	45-30-0255	Rubber Slug	(4)
67	-----	3rd Gear	(1)
68	-----	Pulley Shaft	(1)
69	43-96-0105	Key	(1)
70	02-04-1525	Ball Bearing	(1)
71	45-88-0406	Washer	(1)
72	28-14-0180	Bearing Plate Bottom	(1)
73	06-82-7261	6-19 x 11/16" Pan Hd. Slit. Plast. T-15 Screw	(2)
74	06-82-7270	8-16 x 5/8" Pan Hd. Slit. Plast. T-20 Screw	(12)
★75	-----	Handle - Left	(1)
76	40-50-0650	Compression Spring	(1)
77	-----	Terminal Block Assembly	(1)
78	42-55-0100	Carrying Case	(1)
79	06-82-5294	1/4-20 x 3/4" Pan Hd. Tapt. T-30 Screw	(2)
80	23-66-1000	Switch	(1)
81	06-82-7251	8-16 x 3/8" Pan Hd. Slit. Plast. T-20 Screw	(1)
★82	-----	Lock-Off Shuttle	(1)
★83	40-50-0272	Shuttle Spring	(1)
84	10-20-1865	LED Label	(1)
85	-----	PCB	(1)
★86	-----	Handle - Right	(1)
87	06-82-0045	3/8"-16 UNC-3A Hex Recess Screw	(1)
88	31-44-0095	Front T-Handle	(1)
89	06-82-5316	8-32 x 1/2" Pan Hd. Slit. Tapt. T-20 Screw	(2)
90	45-88-0825	Washer	(2)
91	-----	Motor Cover	(1)
92	-----	Wire Assembly	(1)
93	-----	LED Switch Box	(1)
★94	14-34-2003	Handle/Shuttle Kit	(1)
95	31-15-0205	Motor Cover Assembly	(1)
96	28-90-0015	Deck Assembly	(1)
105	●	Bevel Pinion Assembly } ORDER AS A SET (1)	
106	●	Bevel/Spur Gear Assy. } Cat. No. 32-05-2629 (1)	
107	14-73-0040	Pulley Gear Assembly	(1)
108	14-30-0050	Top Gearcase Assembly	(1)
110	14-20-0025	Electronics Kit	(1)
113	05-88-0928	M3 x 5mm Pan Hd. T-10 Screw	(2)
114	45-88-1980	Spring washer	(2)
115	-----	Leadwire Assembly - Black	(1)
116	-----	Leadwire Assembly - Red	(1)
117	14-46-2397	Leadwire/Screw/Washer Kit	(1)
118	14-46-2016	Brush Card Assembly	(1)
★119	45-24-9003	Shuttle Kit	(1)

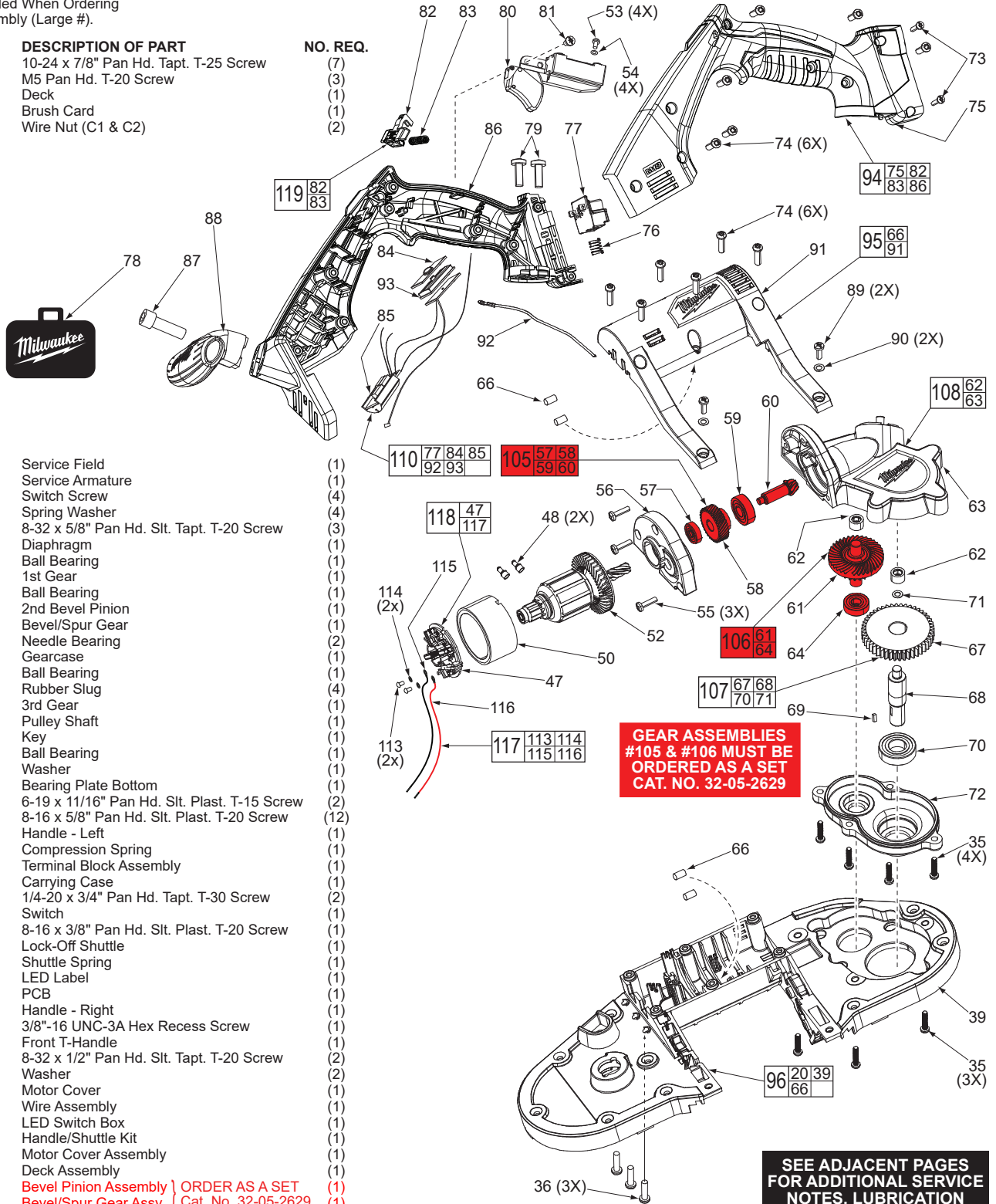

**FIG. NOTE:**  
64,70 Orient the Ball Bearings so the seal faces the gears.

68 Apply approximately .1g Loctite® C5-A Copper Anti-Seize (or equivalent) to bottom portion of Pulley Shaft that fits into Rear Pulley (4).

**MILWAUKEE ELECTRIC TOOL CORPORATION**  
13135 W. LISBON RD., BROOKFIELD, WI 53005

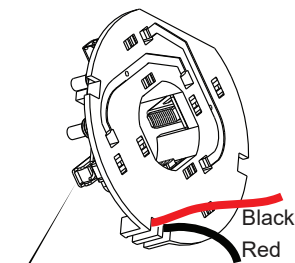

Black  
Red

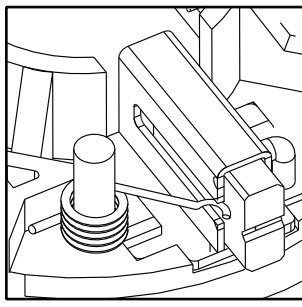

**NOTE:**

As an aid to prevent damage to the armature commutator or the brushes when removing and installing the armature assembly, it is recommended to pull the carbon brushes partially back into the brush tube. The carbon brushes will be held in place with the brush spring moving from the rear of the brush to the side of the brush.

In the unlikely event that the spring pops off follow the instructions below.

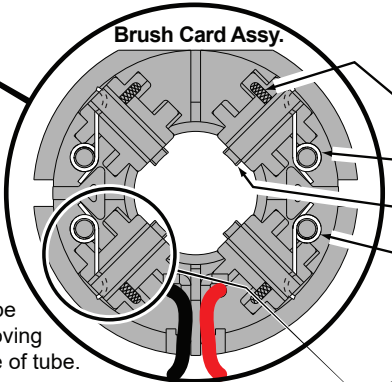

**Brush Card Assy.**

- Brush Shunt (4 places)
- Right Brush Spring (2x)
- Carbon Brush (4x)
- Left Brush Spring (2x)

Be sure carbon brush is in brush tube with brush shunt moving freely in side groove of tube.

Place brush spring over post with short leg positioned downward as shown. Be sure spring is completely down with short leg trapped against 'Y' shaped wall on brush card.

While holding spring in place, bring the long leg of spring over the brush tube and through rear opening of tube. Position rounded hook of spring in groove on back of carbon brush. Be sure to check for free movement between carbon brush, brush shunt and brush spring.

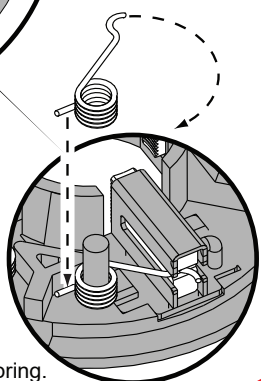

Wrong

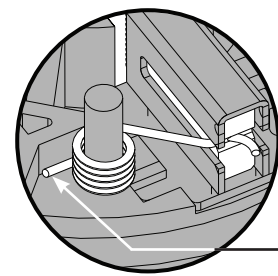

Correct

Short leg of spring to the bottom

★ = Part number change from previous service parts list.

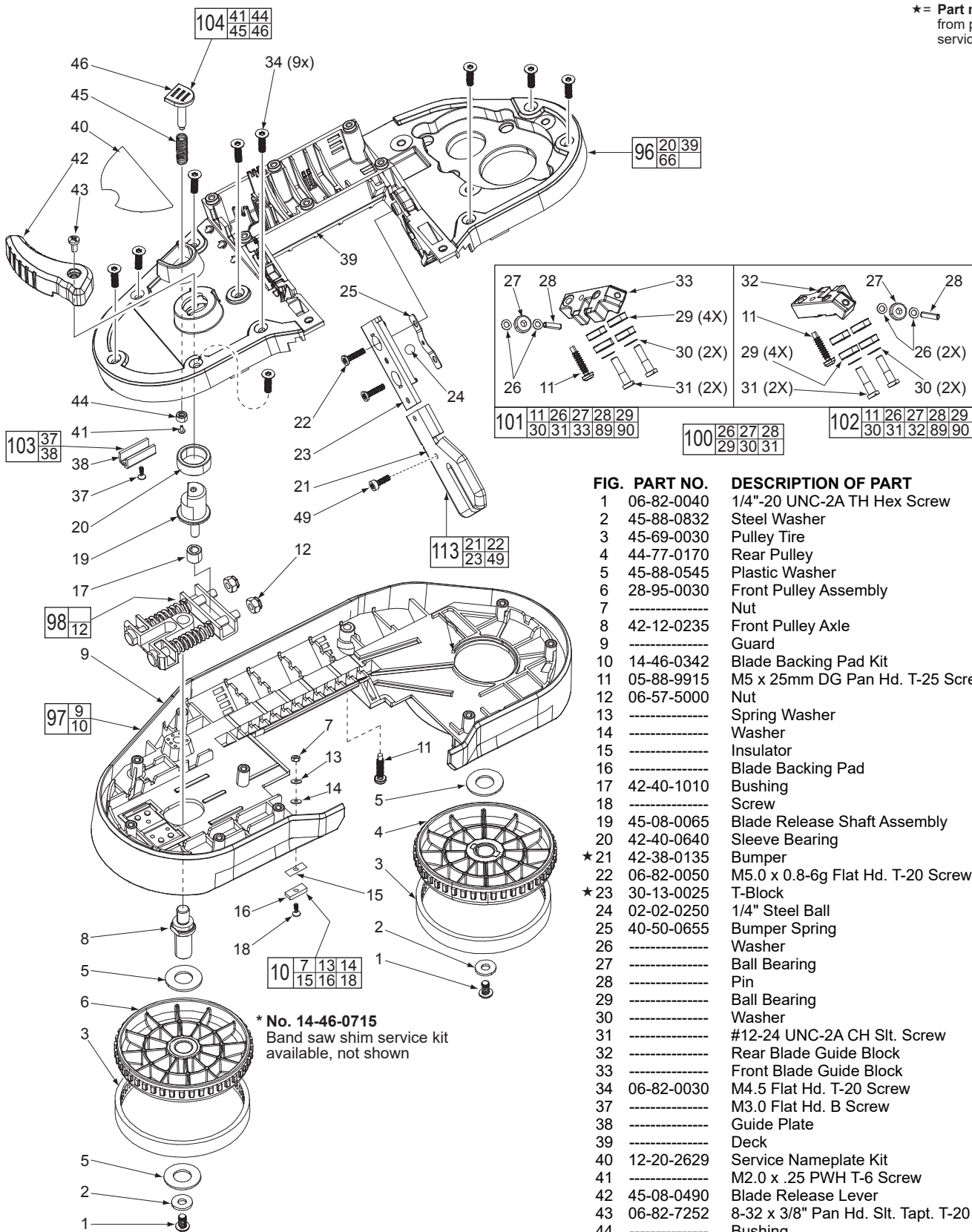
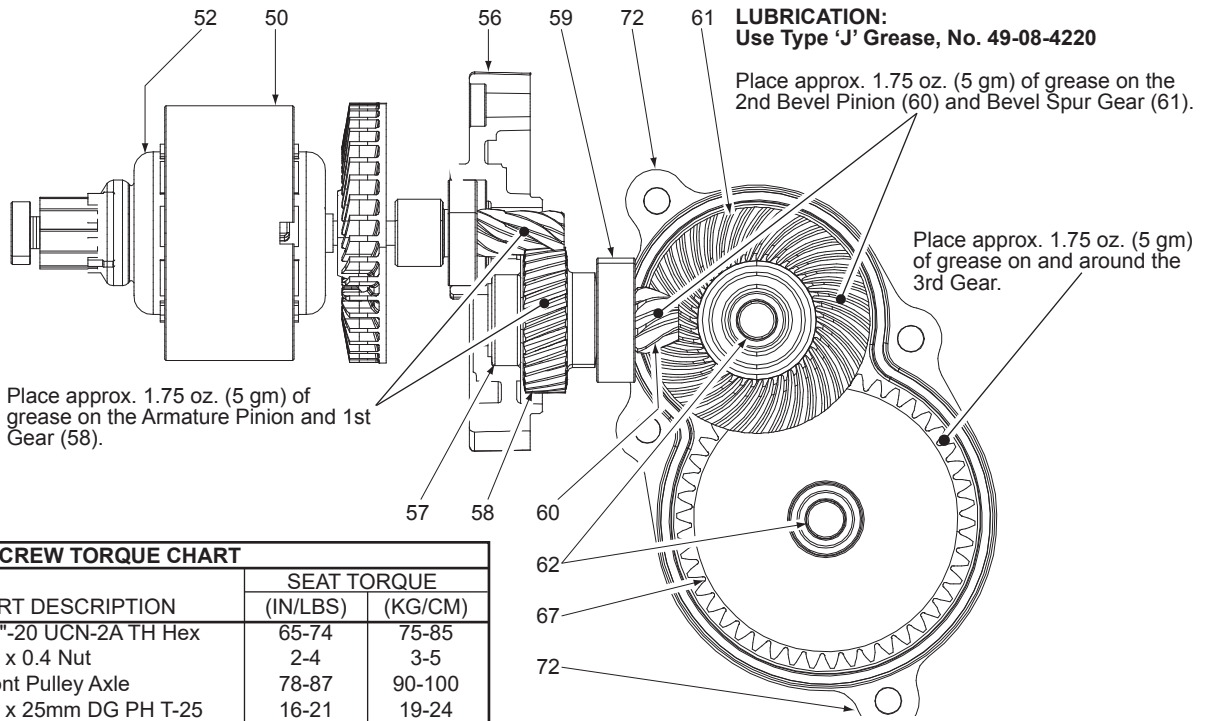
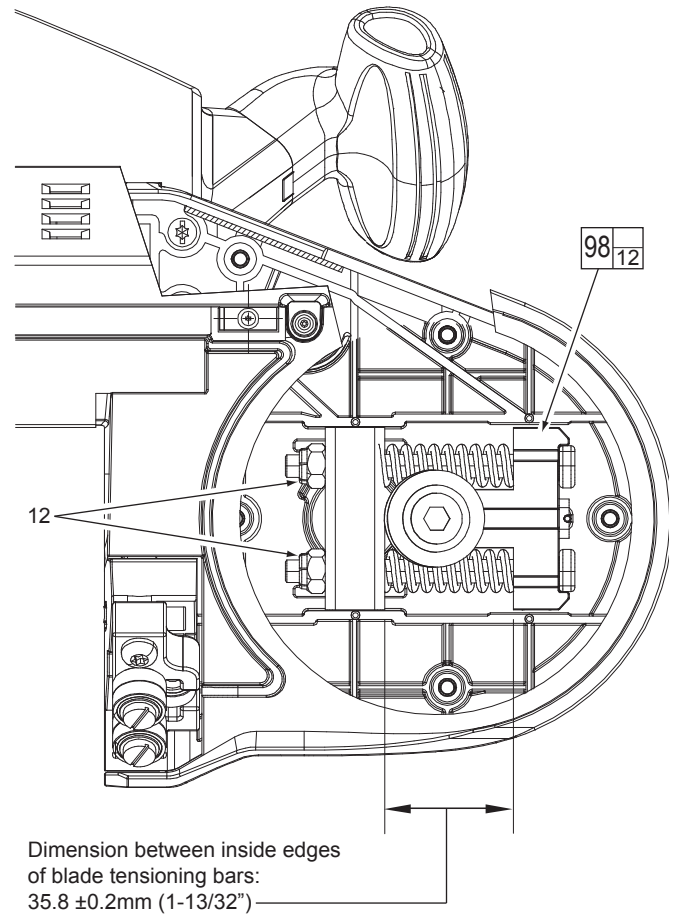

FIG.	PART NO.	DESCRIPTION OF PART	NO. REQ.
1	06-82-0040	1/4"-20 UNC-2A TH Hex Screw	(2)
2	45-88-0832	Steel Washer	(2)
3	45-69-0030	Pulley Tire	(2)
4	44-77-0170	Rear Pulley	(1)
5	45-88-0545	Plastic Washer	(3)
6	28-95-0030	Front Pulley Assembly	(1)
7	-----	Nut	(1)
8	42-12-0235	Front Pulley Axle	(1)
9	-----	Guard	(1)
10	14-46-0342	Blade Backing Pad Kit	(1)
11	05-88-9915	M5 x 25mm DG Pan Hd. T-25 Screw	(3)
12	06-57-5000	Nut	(2)
13	-----	Spring Washer	(1)
14	-----	Washer	(1)
15	-----	Insulator	(1)
16	-----	Blade Backing Pad	(1)
17	42-40-1010	Bushing	(1)
18	-----	Screw	(1)
19	45-08-0065	Blade Release Shaft Assembly	(1)
20	42-40-0640	Sleeve Bearing	(1)
★21	42-38-0135	Bumper	(1)
22	06-82-0050	M5.0 x 0.8-6g Flat Hd. T-20 Screw	(2)
★23	30-13-0025	T-Block	(1)
24	02-02-0250	1/4" Steel Ball	(1)
25	40-50-0655	Bumper Spring	(1)
26	-----	Washer	(4)
27	-----	Ball Bearing	(2)
28	-----	Pin	(2)
29	-----	Ball Bearing	(8)
30	-----	Washer	(4)
31	-----	#12-24 UNC-2A CH Slit. Screw	(4)
32	-----	Rear Blade Guide Block	(1)
33	-----	Front Blade Guide Block	(1)
34	06-82-0030	M4.5 Flat Hd. T-20 Screw	(9)
37	-----	M3.0 Flat Hd. B Screw	(1)
38	-----	Guide Plate	(1)
39	-----	Deck	(1)
40	12-20-2629	Service Nameplate Kit	(1)
41	-----	M2.0 x .25 PWH T-6 Screw	(1)
42	45-08-0490	Blade Release Lever	(1)
43	06-82-7252	8-32 x 3/8" Pan Hd. Slit. Tapt. T-20 Screw	(1)
44	-----	Bushing	(1)
45	-----	Spring	(1)
46	-----	Blade Ejection Pin	(1)
★49	14-74-0275	Bandsaw Fixed Material Guide w/ Screw	(1)
96	28-90-0015	Deck Assembly	(1)
97	28-41-0052	Guard Assembly	(1)
98	42-18-0025	Blade Tension Bar Assembly	(1)
100	14-46-0465	Guide Block Hardware Kit	(1)
101	42-28-0410	Front Guide Block Assembly	(1)
102	42-28-0420	Rear Guide Block Assembly	(1)
103	44-66-0325	Guide Plate Kit	(1)
104	44-60-0240	Blade Ejection Shaft Kit	(1)
★113	42-38-0010	Bumper Assembly	(1)

- FIG. NOTE:**
- 24 Apply Loctite® Silver Grade Anti-Seize Stick 80209 (or equivalent) to Steel Ball.
  - 8 Apply Loctite® Cleaner 755 (or equivalent) to Front Pulley Axle thread first then place a drop or two of Blue Loctite® 443 (or equivalent) to axle threads.
  - 18,41 Apply a drop of Blue Loctite® 443 (or equivalent) to threads of each screw.
  - 9,38 Apply Loctite® C5-A Copper Anti-Seize (or equivalent) to metal insert in Guard and to Guide Plate. Approximately .1g for each part.



SCREW TORQUE CHART				
ITEM	PART NO.	PART DESCRIPTION	SEAT TORQUE	
			(IN/LBS)	(KG/CM)
1	06-82-0040	1/4"-20 UCN-2A TH Hex	65-74	75-85
7	-----	M2 x 0.4 Nut	2-4	3-5
8	42-12-0235	Front Pulley Axle	78-87	90-100
11	05-88-9915	M5 x 25mm DG PH T-25	16-21	19-24
12	06-57-5000	Flex-Loc Nut	To Assembly Length	
18	-----	M2 x 0.4 T-6	2-4	3-5
22	06-82-0050	M5 x .8-6g FH T-20	26-30	30-35
31	06-82-0120	#12-24 UNC-2A CH Slotted	39-48	45-55
34	06-82-0030	M4.5 FH T-20	16-21	19-24
35	06-82-5574	#10-24 x 7/8" PH T-25	39-48	45-55
36	06-82-0035	M5.0 PH T-20	22-26	25-30
37	06-82-0010	M3 FH B	6-9	7-10
41	06-82-0025	M2.0 x .25 PWH T-6	2-4	3-5
43	06-82-7252	#8-32 x 3/8" PH T-20	22-26	25-30
55	06-82-5320	#8-32 x 5/8" PH T-20	26-31	30-36
73	06-82-7261	#6-19 x 11/16" PH T-15	16-21	19-24
74	06-82-7270	#8-16 x 5/8" PH T-20	16-21	19-24
79	06-82-5294	1/4"-20 UNC-2A PH T-30	65-74	75-85
81	06-82-7251	#8-16 x 3/8" PH T-20	10-14	12-16
87	06-82-0045	3/8"-16 UNC-3A T-20	87-104	100-120
89	06-82-5316	#8-32 x 1/2" PH T-20	16-21	19-24



AS AN AID TO REASSEMBLY, TAKE NOTICE OF WIRE ROUTING AND POSITION IN WIRE GUIDES AND TRAPS WHILE DISMANTLING TOOL.

BE CAREFUL AND AVOID PINCHING WIRES BETWEEN HANDLE HALVES WHEN ASSEMBLING.

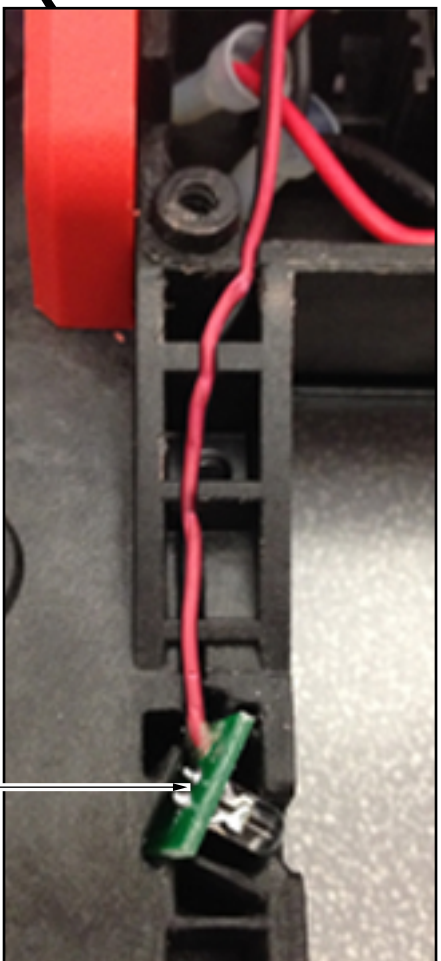
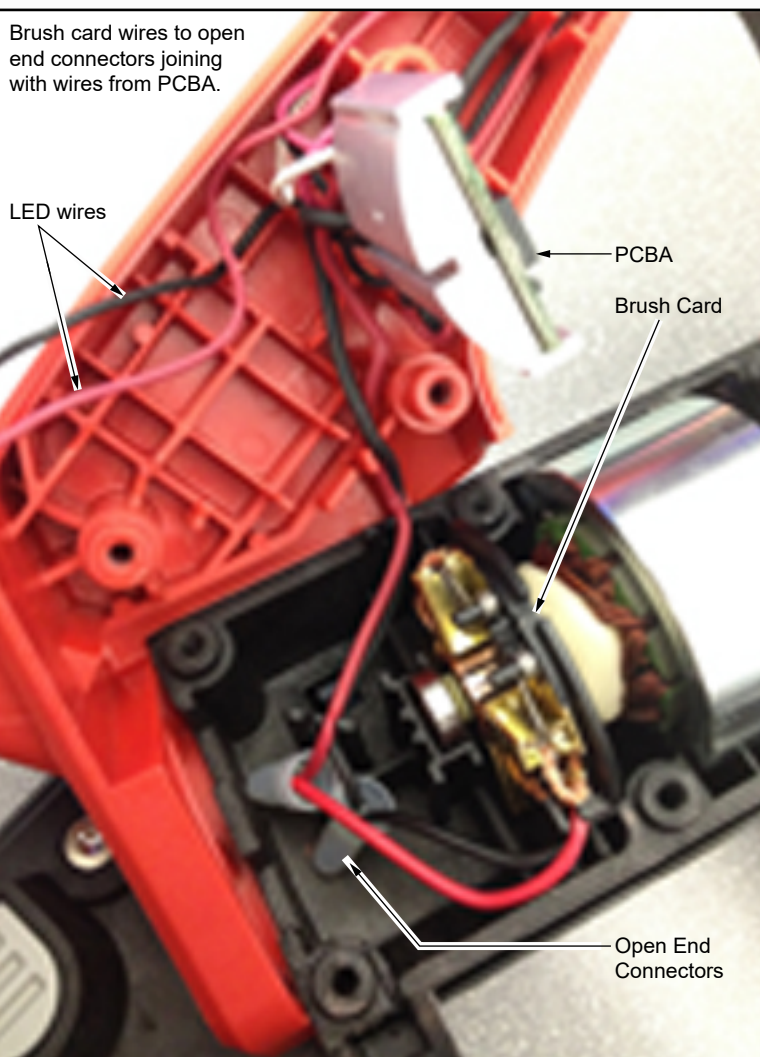
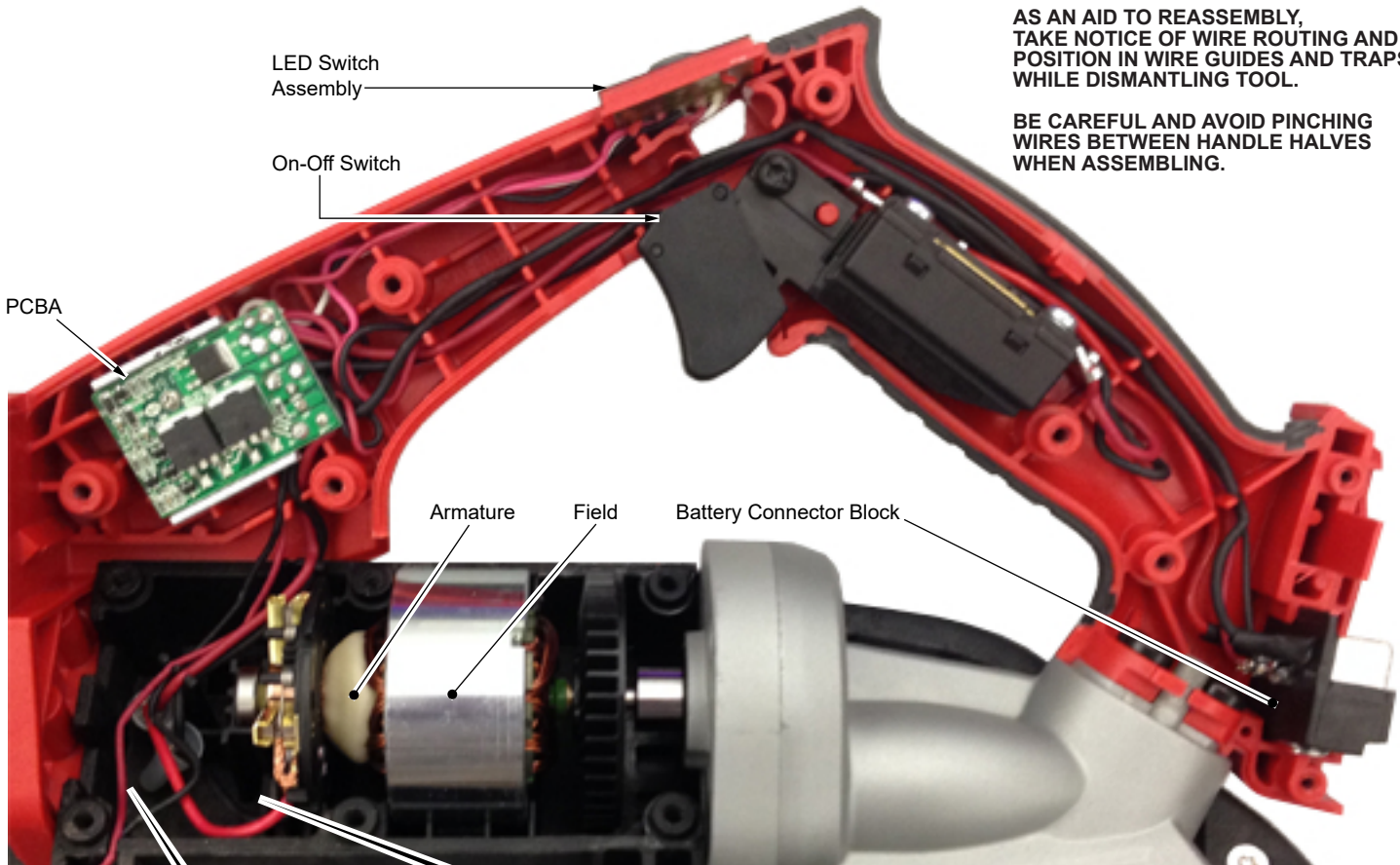

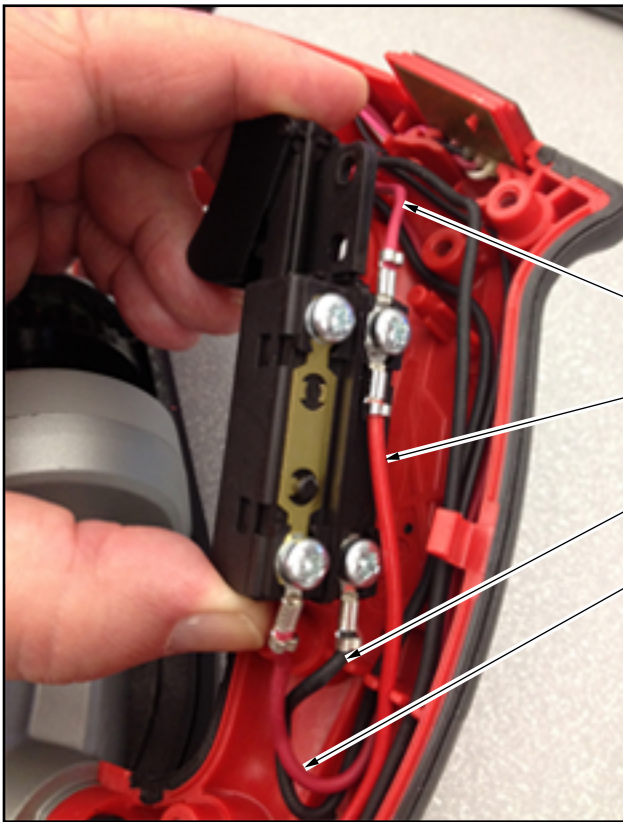

Red wire from PCBA

Red wire from Battery Connector Block

Black wire from PCBA

Red wire from PCBA

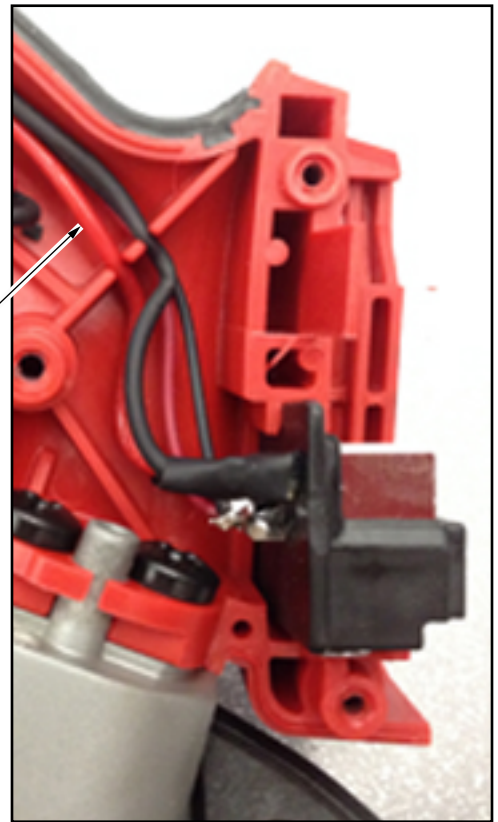

AS AN AID TO REASSEMBLY, TAKE NOTICE OF WIRE ROUTING AND POSITION IN WIRE GUIDES AND TRAPS WHILE DISMANTLING TOOL.

BE CAREFUL AND AVOID PINCHING WIRES BETWEEN HANDLE HALVES WHEN ASSEMBLING.

