



SERVICE PARTS

BULLETIN NO.
54-47-0230

SPECIFY CATALOG NO. AND SERIAL NO. WHEN ORDERING PARTS		REVISED BULLETIN	DATE
M12™ 3/8" RATCHET			Aug 2021
CATALOG NO.	SERIAL NUMBER	WIRING INSTRUCTION	
2457-20	D54A	See Reverse Side	

EXAMPLE:
Component Parts
(Small #) Are Included
When Ordering The
Assembly (Large #).

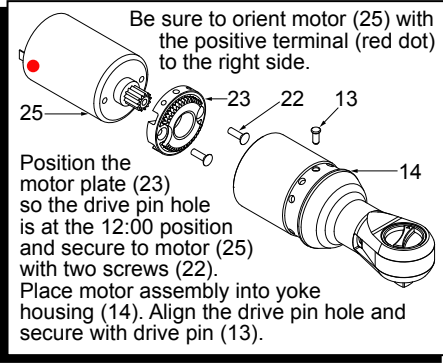

- FIG. LUBRICATION (Type 'E' Grease, No. 49-08-4122):**
- 17 Apply a moderate coating of grease to the small cylindrical surface that goes into driver bushing and to the large cylindrical surface that is surrounded by the two needle bearings.
 - 18 Apply a moderate coating of grease to the three axes of the carrier assembly prior to installing the planet gears.
 - 20,25 Apply a heavy coating of grease to the inside diameter gear teeth of the ring gear and the teeth of the motor pinion.
 - 21 Apply a light coat of grease to the surface of the washer.
- FIG. NOTES 28,31**
- 34 Use a similar size tool or pin to remove the spring pin from the handle halves and switch paddle. When reinstalling pin, align the holes and carefully press or tap the pin in place.

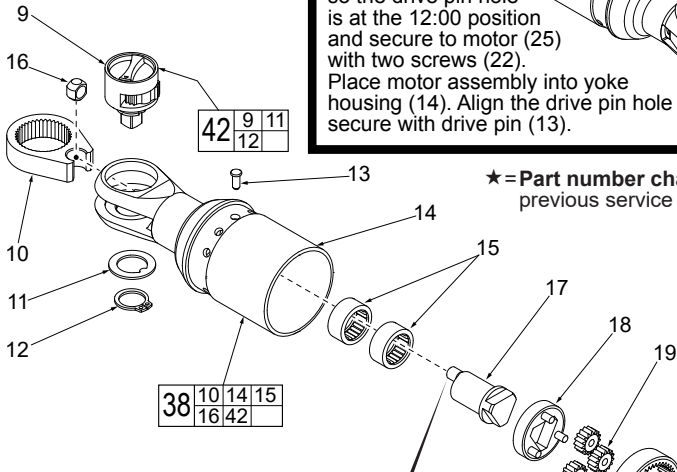

NOTE: If the tool that is being serviced has a plastic motor plate (23) use four M3 x 12mm screws (44) from kit (40) on the handle halves. If the motor plate is metal use four M3 x 10mm screws (22) instead.

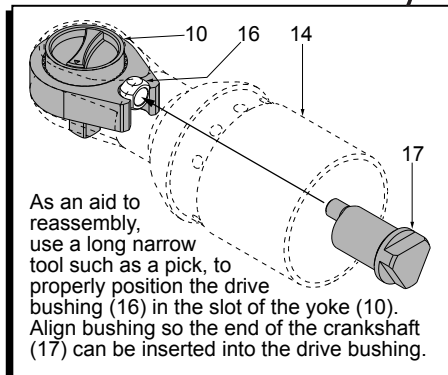

FIG.	PART NO.	DESCRIPTION OF PART	NO. REQ.
9	-----	3/8" Anvil Assembly	(1)
10	-----	Yoke	(1)
11	-----	Friction Plate	(1)
12	-----	Retaining Ring	(1)
13	44-60-0890	Drive Pin	(1)
14	-----	Yoke Housing	(1)
15	-----	Needle Bearing	(2)
16	-----	Driver Bushing	(1)
17	36-17-0305	Crankshaft	(1)
18	28-23-0500	Carrier Assembly	(1)
19	32-62-0400	Planet Gear	(3)
20	32-65-0350	Ring Gear	(1)
21	45-88-2105	Washer	(1)
22	-----	M3 x 10 T-10 Screw	(2)
23	-----	Motor Plate	(1)
24	-----	LED Assembly (Component of PCBA)	(1)
25	23-30-0650	Motor Assembly	(1)
26	06-82-2385	M2.6 x 14 ST T-8 Screw	(4)
27	06-82-2395	M2.6 x 10 ST T-8 Screw	(1)
28	-----	Handle Cover - Right	(1)
29	-----	Switch	(1)
30	-----	PCB Assembly with LED	(1)
31	12-20-2454	Service Nameplate (Not Shown)	(1)
32	23-66-2910	Lockout Switch	(1)
33	-----	Battery Connector	(1)
34	44-60-0575	Spring Pin	(1)

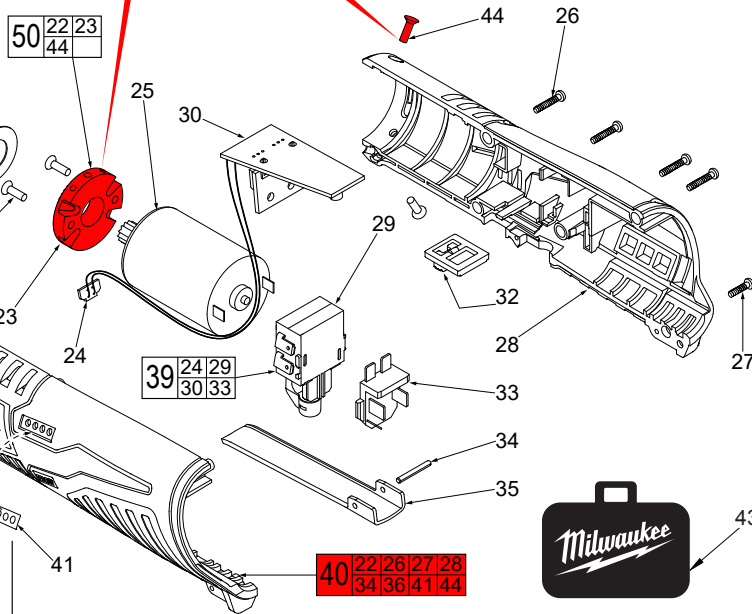
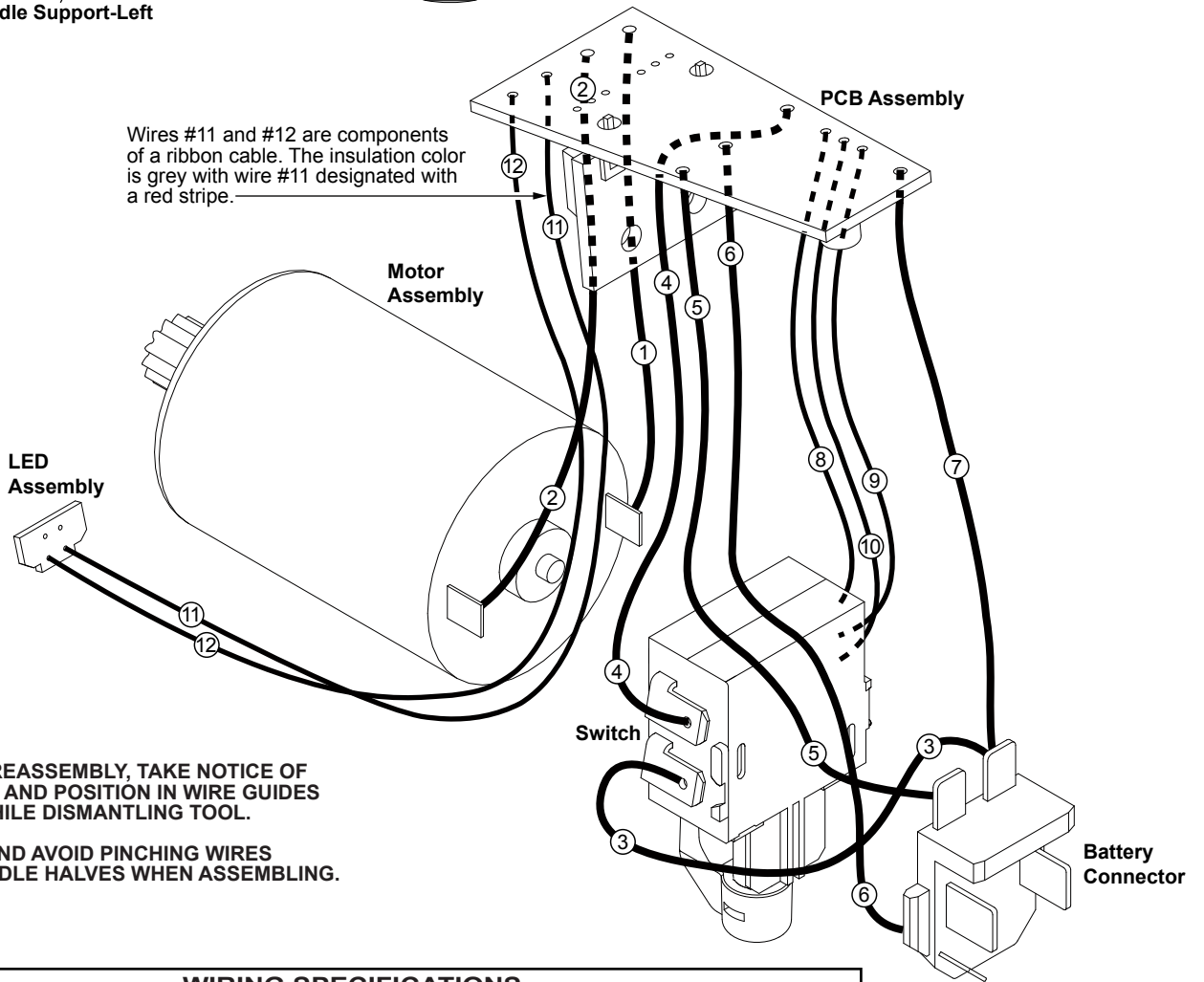
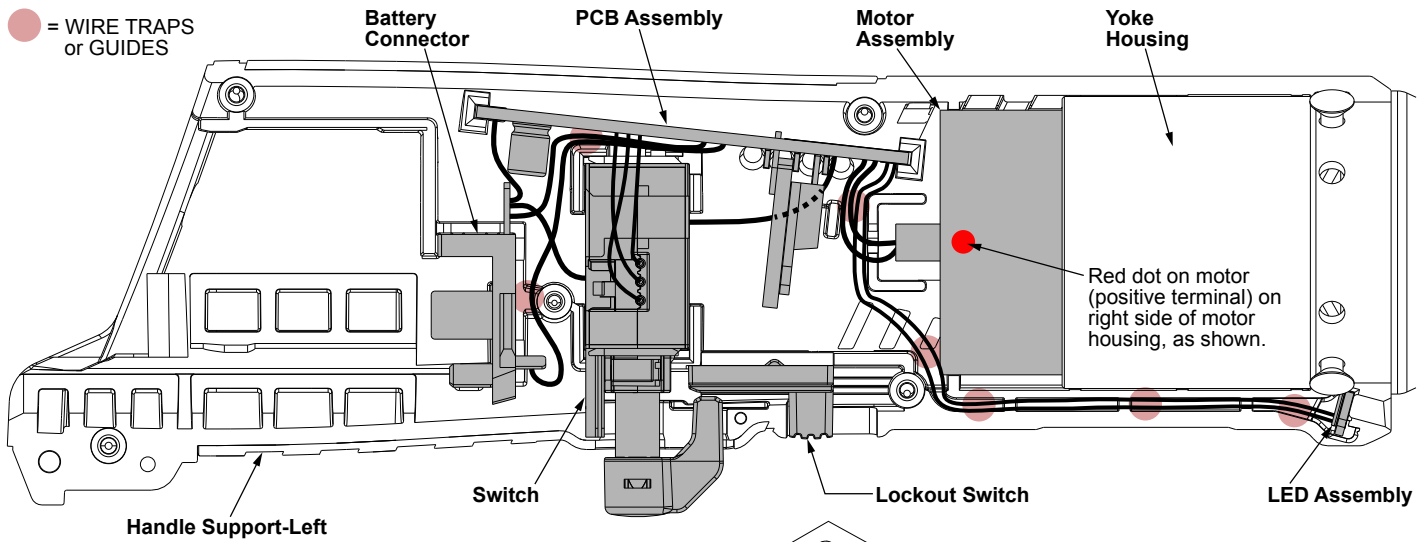

FIG.	PART NO.	DESCRIPTION OF PART	NO. REQ.
35	44-10-0740	Switch Paddle	(1)
36	-----	Handle Support - Left	(1)
★38	14-46-2485	3/8" Yoke Housing Assembly	(1)
39	23-66-3020	Switch Assembly	(1)
40	31-44-2711	Handle Kit	(1)
41	-----	Fuel Gauge Label	(1)
★42	42-06-1030	3/8" Anvil Service Kit	(1)
43	42-55-2456	Contractors Bag	(1)
★44	-----	M3 x 12 T-10 Screw	(4)
★50	44-66-1241	Motor Plate Service Kit	(1)





AS AN AID TO REASSEMBLY, TAKE NOTICE OF WIRE ROUTING AND POSITION IN WIRE GUIDES AND TRAPS WHILE DISMANTLING TOOL.

BE CAREFUL AND AVOID PINCHING WIRES BETWEEN HANDLE HALVES WHEN ASSEMBLING.

WIRING SPECIFICATIONS

Wire No.	Wire Color	Origin or Part No.	Gauge	Length	Terminals, Connectors and End Wire Preparation
1	Red	23-66-3020	--	--	Component of the Switch Assembly.
2	White	23-66-3020	--	--	Component of the Switch Assembly.
3	Red	23-66-3020	--	--	Component of the Switch Assembly.
4	Black	23-66-3020	--	--	Component of the Switch Assembly.
5	Black	23-66-3020	--	--	Component of the Switch Assembly.
6	White	23-66-3020	--	--	Component of the Switch Assembly.
7	Red	23-66-3020	--	--	Component of the Switch Assembly.
8	Yellow	23-66-3020	--	--	Component of the Switch Assembly.
9	Blue	23-66-3020	--	--	Component of the Switch Assembly.
10	Black	23-66-3020	--	--	Component of the Switch Assembly.
11	Grey w/ Red Stripe	23-66-3020	--	--	Component of the Switch Assembly.
12	Grey	23-66-3020	--	--	Component of the Switch Assembly.

NOTE:

All leads must be held to ± 1/16".
All lead lengths are before stripping.

TERMINAL DESCRIPTION		
Code	Part No.	Qty.
CONNECTOR DESCRIPTION		