



SERVICE PARTS LIST

BULLETIN NO.
54-12-1405

SPECIFY CATALOG NO. AND SERIAL NO. WHEN ORDERING PARTS		REVISED BULLETIN 54-12-1404	DATE Nov. '96
SUPER HOLE-SHOOTER			
CATALOG NO. 2404-1	SERIAL NUMBER 568B	WIRING INSTRUCTION 58-01-0940	

EXAMPLE:
 Component Parts (Small #)
 Are Included When Ordering
 The Assembly (Large #).

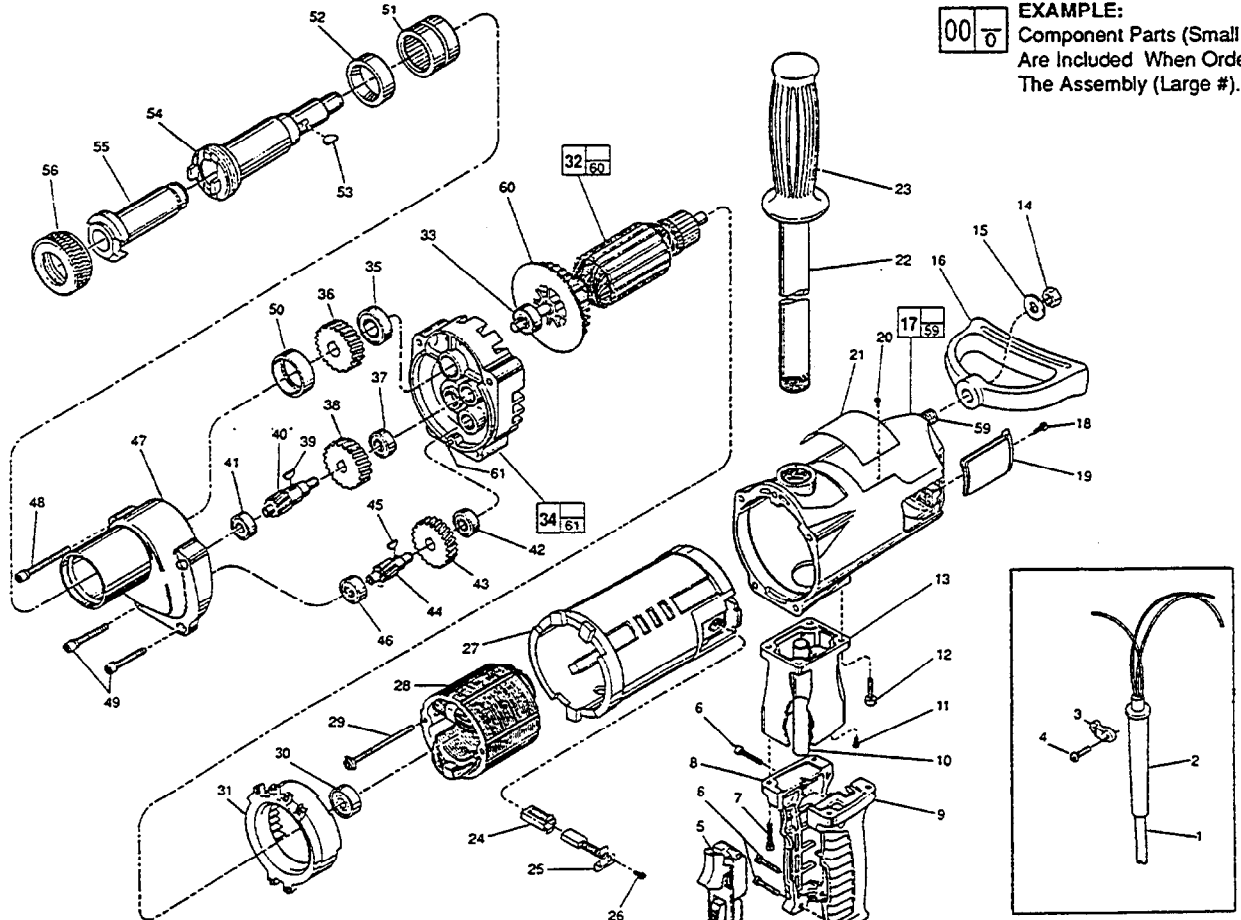

FIG.	PART NO.	DESCRIPTION OF PART	NO.	REQ.
	1	22-64-0121 Cord Set	(1)	(1)
	2	44-76-0140 Cord Protector	(1)	(1)
	3	31-17-0156 Cord Clamp	(1)	(1)
	4	06-82-7270 8-16 x 5/8" Slotted Plastite T-20 Screw	(2)	(2)
	5	23-66-1420 Switch	(1)	(1)
	6	06-82-7326 8-16 x 1" Slotted Plastite T-20 Screw	(3)	(3)
★	7	06-82-5382 1/4-20 x 3/4" Pan Hd. Taptite T-27 Screw	(4)	(4)
★	8	31-44-1441 Right Handle Half	(1)	(1)
★	9	31-44-1446 Left Handle Half	(1)	(1)
	10	23-16-1440 Insulating Tube	(1)	(1)
	11	06-95-5200 8-32 x 5/16" Slotted Hex Hd. Screw	(1)	(1)
	12	06-95-5645 1/4-20 x 3/4" Pan Hd. Taptite Screw	(4)	(4)
★	13	25-86-1615 Handle Spacer	(1)	(1)
	14	06-55-2850 1/2-13 Hex Nut	(1)	(1)
	15	45-88-5253 Thrust Washer	(1)	(1)
	16	31-44-1450 Spade Handle	(1)	(1)
	17	28-50-6365 Motor Housing	(1)	(1)
	18	06-82-5316 8-32 x 1/2" Slit. Pan Hd. Taptite T-20 Screw	(2)	(2)
	19	22-32-0350 Brush Cover	(2)	(2)
	20	06-72-1720 Nameplate Rivet	(2)	(2)
	21	12-15-7510 Service Nameplate	(1)	(1)
	22	43-62-0121 Pipe Handle	(1)	(1)
	23	43-62-0246 Handle Grip	(1)	(1)
	24	22-20-0680 Brush Tube	(2)	(2)
	25	22-18-0701 Carbon Brush Assembly	(2)	(2)
	26	06-82-8835 8-32 x 5/16" Pan Hd. T-20 Sems	(2)	(2)
	27	23-16-1420 Insulated Housing	(1)	(1)
	28	18-70-0310 120 V. Field	(1)	(1)
	29	06-82-9072 10-24 x 2-1/8" Pan Hd. T-25 Sems	(2)	(2)
	30	02-04-1041 Ball Bearing	(1)	(1)
	31	42-14-0291 Baffle	(1)	(1)
	32	16-70-0360 120 V. Armature	(1)	(1)
	33	02-04-1229 Ball Bearing	(1)	(1)
	34	14-13-0230 Diaphragm Assembly	(1)	(1)
	35	02-04-1710 Ball Bearing	(1)	(1)
	36	32-75-1261 Spindle Gear	(1)	(1)
	37	02-04-1022 Ball Bearing	(1)	(1)
	38	32-44-1101 Intermediate Gear	(1)	(1)

FIG.	PART NO.	DESCRIPTION OF PART	NO.	REQ.
	39	06-42-2000 Woodruff Key	(1)	(1)
	40	36-66-0571 Intermediate Pinion Shaft	(1)	(1)
	41	02-04-1210 Ball Bearing	(1)	(1)
	42	02-04-0910 Ball Bearing	(1)	(1)
	43	32-42-1201 Intermediate Gear	(1)	(1)
	44	36-66-0551 Intermediate Pinion Shaft	(1)	(1)
	45	06-42-1200 Woodruff Key	(1)	(1)
	46	02-04-0910 Ball Bearing	(1)	(1)
	47	28-14-1940 Gear Case	(1)	(1)
	48	06-82-8550 1/4-20 x 3-1/8" Fil. Taptite T-30 Sems	(2)	(2)
	49	06-82-8396 1/4-20 x 2-1/4" Fil. Taptite T-30 Sems	(2)	(2)
	50	42-24-0070 Thrust Bearing	(1)	(1)
	51	02-50-9976 Needle Bearing	(1)	(1)
	52	45-06-0380 Oil Seal	(1)	(1)
	53	06-42-2400 Woodruff Key	(1)	(1)
	54	38-50-5460 Spindle	(1)	(1)
	55	45-34-0110 No. 3 Taper Socket	(1)	(1)
	56	42-52-0050 Taper Socket Cap	(1)	(1)
	59	06-14-0010 1/2 x 13 x 1-3/8" Hex Hd. Bolt	(1)	(1)
	60	22-84-0790 Fan	(1)	(1)
	61	06-65-1155 Pin	(1)	(1)

FIG. 47 LUBRICATION
7-3/4 Oz. "E" Grease, No. 49-08-4122.

FIG. 12 NOTES
Tighten one screw until lockwasher is touching handle spacer. Tighten the diagonally opposite screw (70-80 lbs./in. on new motor housing) and then sequentially tighten the other screws.

48,49 Apply Type 242 Blue Loctite.

MILWAUKEE ELECTRIC TOOL CORPORATION
13135 W. LISBON RD., BROOKFIELD, WI 53005