



SERVICE PARTS LIST

BULLETIN NO.
54-12-1401

SPECIFY CATALOG NO. AND SERIAL NO. WHEN ORDERING PARTS		REVISED BULLETIN	DATE
1-1/4" ELECTRIC DRILL		54-12-1400	May '83
CATALOG NO. 2404-1	STARTING SERIAL NO. 568-3501	WIRING INSTRUCTION	
		58-01-0566	
CAT. NO. 2404-6	START SER. NO. 568-3501	BILINGUAL LABEL 10-98-6400	

FOR CAT. NO. 2404-3
(240V) TOOL USE:
16-76-0110 ARMATURE
18-76-0070 FIELD
22-64-4155 CORD SET

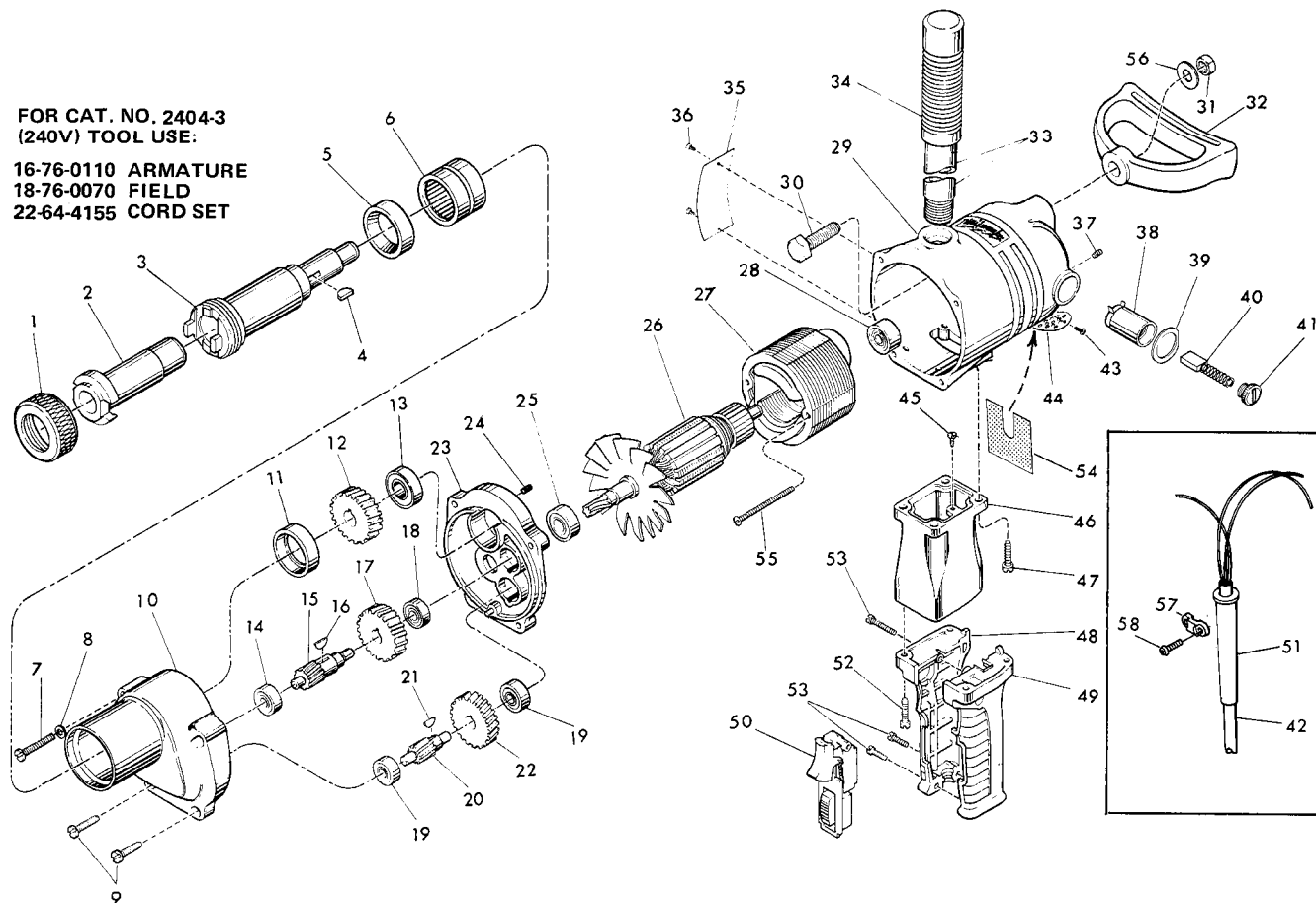

FIG.	PART NO.	DESCRIPTION OF PART	NO. REQ.
1	42-52-0050	Taper Socket Cap	(1)
2	45-34-0050	No. 3 Taper Socket	(1)
3	38-50-0701	Spindle	(1)
4	06-42-2400	Woodruff Key	(1)
5	45-06-0080	Oil Seal	(1)
6	02-50-9640	Needle Bearing	(1)
7	06-81-1975	1/4-20x2-1/4 Fil. Hd. Screw	(2)
8	06-97-3800	Lock Washer	(2)
9	06-81-7900	1/4-20x1-1/2 Fil. Hd. Sem	(2)
10	28-14-0121	Gear Case	(1)
11	42-24-0070	Thrust Bearing	(1)
12	32-75-1261	Spindle Gear	(1)
13	02-20-1720	Ball Bearing	(1)
14	02-04-1210	Ball Bearing	(1)
15	36-66-0571	Pinion Shaft	(1)
16	06-42-2000	Woodruff Key	(1)
17	32-44-1101	Intermediate Gear	(1)
18	02-04-1020	Ball Bearing	(1)
19	02-04-0910	Ball Bearing	(2)
20	36-66-0551	Pinion Shaft	(1)
21	06-42-1200	Woodruff Key	(1)
22	32-42-1201	Intermediate Gear	(1)
23	28-28-1181	Diaphragm (Includes 06-65-1206 Groove Pin & Fig. No. 24)	(1)
24	45-30-0070	Bearing Retaining Slug	(3)
25	02-04-1260	Ball Bearing	(1)
26	16-70-0110	120V Reversing Armature	(1)
27	18-70-0070	120V Field	(1)
28	02-04-1070	Ball Bearing	(1)
29	28-50-4161	Motor Housing (Includes 45-30-0110 BB Rtnng. Slug & Fig. Nos. 30 & 31)	(1)
30	06-75-0850	1/2-13x1-1/2 Hex Hd. Screw	(1)

FIG.	PART NO.	DESCRIPTION OF PART	NO. REQ.
31	06-55-2850	1/2-13 Hex Nut	(1)
32	31-44-1050	Spade Handle	(1)
33	43-62-0120	Pipe Handle	(1)
34	43-62-0242	Handle Grip	(1)
35	12-99-0040	Nameplate Blank	(1)
36	06-85-0200	6x1/4 Nameplate Screw	(2)
37	06-83-2650	1/4-20x3/8 Knrl. Set Screw	(2)
38	22-22-1015	Brush Holder	(2)
39	23-86-0060	Fiber Washer	(2)
40	22-18-0055	Carbon Brush	(2)
41	23-44-0030	Brush Retaining Screw	(2)
★ 42	22-64-0120	Cord Set	(1)
43	06-81-8650	6-32x1/4 Rd. Hd. Sem	(2)
44	44-66-0180	Cover Plate	(1)
45	06-81-8625	6-32x1/4 Ground Screw	(1)
46	28-86-1601	Handle Spacer	(1)
47	06-81-7800	1/4-20x3/4 Fil. Hd. Sem	(4)
★ 48	31-44-1290	Right Hand Handle Half	(1)
★ 49	31-44-1295	Left Hand Handle Half	(1)
50	23-66-0581	Switch	(1)
★ 51	44-76-0150	Cord Protector	(1)
52	06-81-7550	12-24x3/4 Fil. Hd. Sem	(4)
★ 53	06-95-0219	8-16 x 7/8" Plastite Screw	(3)
54	23-16-0830	Arc Insulator	(1)
55	06-81-9190	10-24x2-1/4 Rd. Hd. Screw	(2)
56	45-88-0310	Flat Washer	(1)
★ 57	31-17-0156	Cord Clamp	(1)
★ 58	06-95-0216	8-16 x 5/8" Plastite Screw	(2)
59	10-98-5987	Caution Label (Not Show'n) Omit For Canadian Tools	(1)