



SERVICE PARTS LIST

BULLETIN NO.
55-24-3303

SPECIFY CATALOG NO. AND SERIAL NO. WHEN ORDERING PARTS		REVISED BULLETIN 55-24-3302	DATE Aug. 2014
M12™ BRUSHLESS 1/2" (13mm) HAMMER-DRILL			
CATALOG NO.	2404-059	STARTING SERIAL NO.	F17D
		WIRING INSTRUCTION	

EXAMPLE:
Component Parts (Small #)
Are Included When Ordering
The Assembly (Large #).

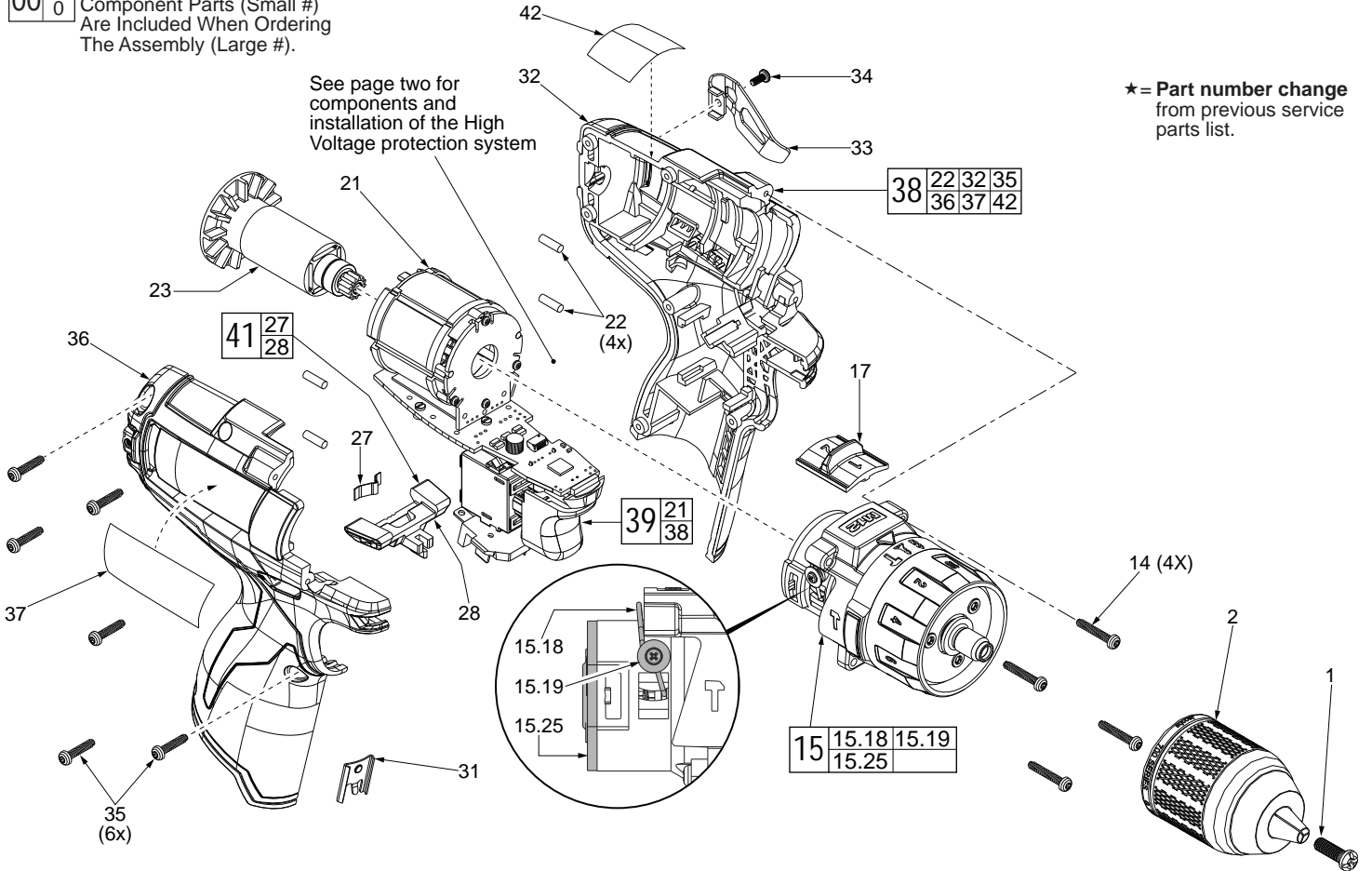

FIG.	PART NO.	DESCRIPTION OF PART	NO. REQ.
1	05-88-1500	M6 x 1.0 x 27mm LH Chuck Screw	(1)
2	42-66-0200	1/2" (13mm) Keyless Chuck	(1)
14	05-88-0780	M3 x 18mm T-10 ST Screw (Gearcase)	(4)
15	14-29-0560	Gearcase Assembly	(1)
15.18	44-10-0710	Speed Selector Lever	(1)
15.19	05-81-0542	M2.3 x 4.5mm ST Screw	(2)
15.25	-----	Motor Mounting Plate	(1)
17	45-24-0325	Speed Selector Button	(1)
21	-----	Motor / Switch / PCBA Assembly	(1)
22	45-30-0270	Rubber Pin	(4)
23	16-07-0400	Service Rotor	(1)
27	40-50-1135	Shuttle Spring	(1)
28	42-42-0610	Forward / Reverse Shuttle	(1)
31	42-70-0058	Housing Connection Clip	(1)
32	-----	Left Housing Half	(1)
33	42-70-0580	Belt Clip	(1)
34	05-88-1010	M2.5 x 6mm Screw	(1)
35	06-82-1080	M3 x 14mm T-10 ST Scr (Handle Halves)	(6)
36	-----	Right Housing Half	(1)
37	-----	Service Nameplate	(1)
38	31-44-2025	Housing Kit	(1)
★39	14-20-1135	Housing / Electronics Kit	(1)
40	42-55-2100	Blow Molded Carrying Case	(1)
★41	42-42-1125	Forward / Reverse Shuttle Kit	(1)
42	10-20-2399	Warning Label (French & Spanish)	(1)
50	23-94-2110	146mm Wire Assembly (See page two) (High Voltage Protection)	(1)

Apply Blue Loctite® thread locking sealant or the equivalent to the threads of the chuck screw (1) before securing chuck to the gearcase spindle.



SCREW TORQUE SPECIFICATION CHART			
FIG.	PART NO.	DESCRIPTION	SEATING TORQUE (IN-LBS)
1	05-88-1500	Chuck Screw	33±2.5
15.19	05-81-0542	Speed Selector Lever Screw	3.5±1
14	05-88-0780	Gearcase Assembly Screw	7.0±2.5
35	06-82-1080	Right Housing Half Screw	7.0±2.5

Model
2402-20,
2402-059
shown

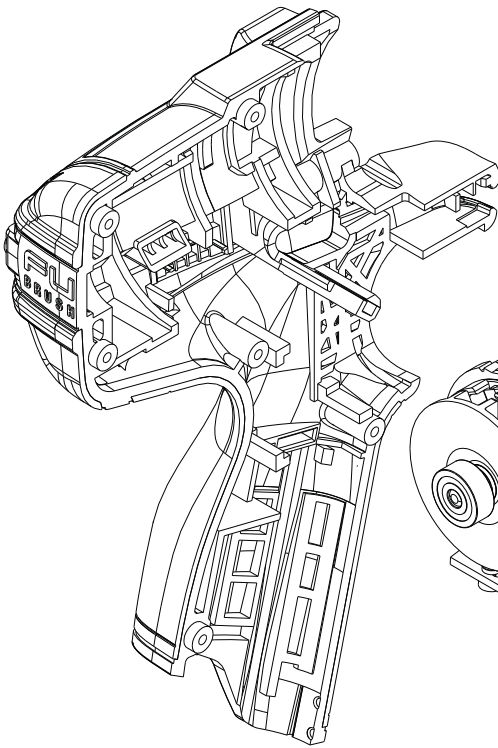

**No. 23-94-2110
146mm Service Wire Assembly
(High Voltage Protection)**

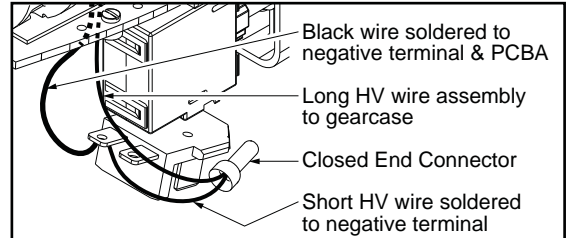
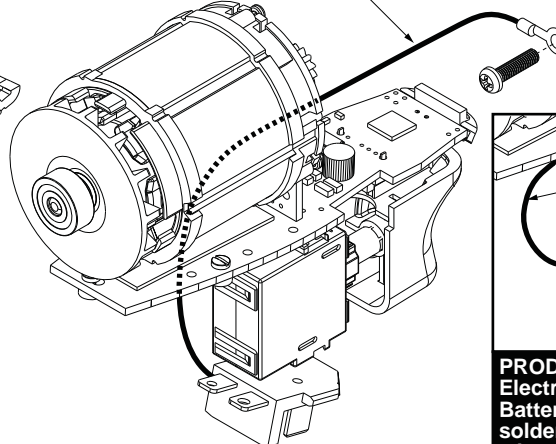
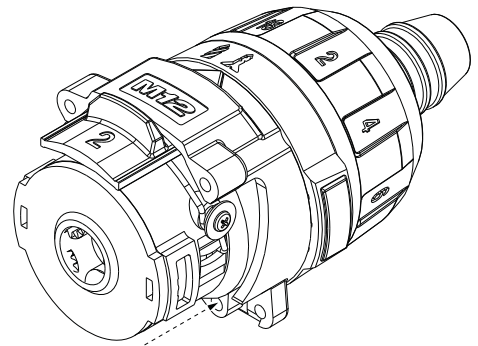

Black wire soldered to negative terminal & PCBA
Long HV wire assembly to gearcase
Closed End Connector
Short HV wire soldered to negative terminal

PRODUCTION WIRING- For ease in production, the Electronics Assembly (Switch, Stator, PCBA and Battery Terminal Block) has a short HV wire pre-soldered to the negative terminal. During production a longer HV wire is joined to the short wire with an open end connector than grounded to the gearcase.

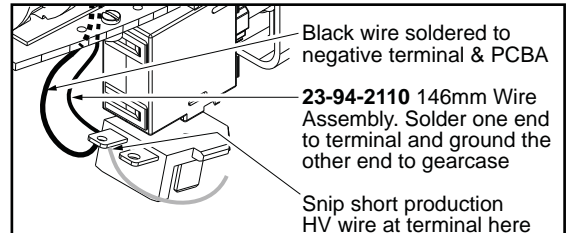

Black wire soldered to negative terminal & PCBA
23-94-2110 146mm Wire Assembly. Solder one end to terminal and ground the other end to gearcase
Snip short production HV wire at terminal here

SERVICE WIRING- When installing a service replacement High Voltage Wire (23-94-2110) it is recommended to snip the old HV wire system at the battery terminal. Remove and discard that short wire, the open end connector and longer wire. Follow the instructions to install new wire assembly.

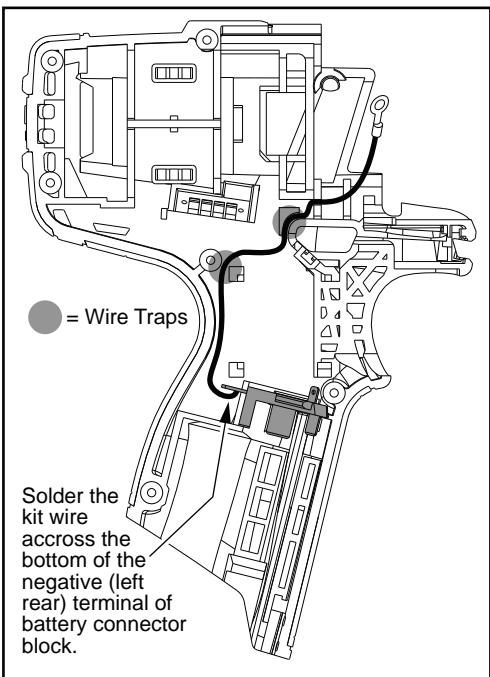
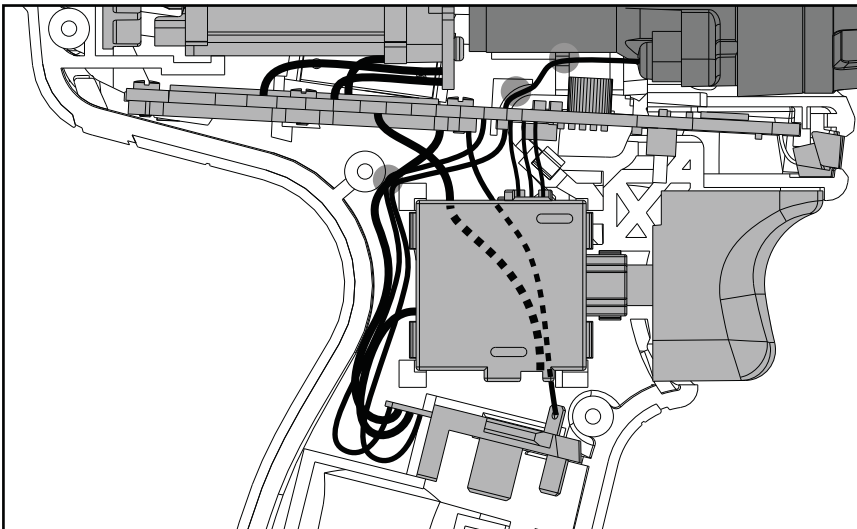

● = Wire Traps

Solder the kit wire across the bottom of the negative (left rear) terminal of battery connector block.

1. Remove the six handle screws, the housing connection clip and the four gearcase screws. Remove housing cover (right housing half). Carefully remove the electronics assembly and gearbox assembly from the housing support (left housing half).
2. With a small side cutter, snip the short production HV wire close to the terminal (see illustration above). Unscrew the ring terminal from the lower right position of the gearcase. Remove and discard the old HV system (short HV wire, the open end connector and longer HV wire).
3. Place the wire strand end of the 146mm High Voltage Wire (23-94-2110) across the bottom of the negative (rear left) terminal of the battery connector block and carefully solder in place (Note wire is to be positioned so wire extends to the left of the terminal, routing into the left housing half). See illustration above.
4. As an aid to routing the HV wire, carefully remove the gearcase assembly from the electronics assembly.
5. Loosely place the electronics assembly into the left housing half. Route the HV wire under the switch/battery connector block wires using the same wire trap at the upper left corner of the switch. Route HV wire behind the PCBA and into the small traps in the left housing half. Lay HV wire across the PCBA facing outward to the right.
6. Place the ring terminal of HV wire over the screw opening in the lower right position of the gearcase (with wire to the inside of the tool) and reinstall the screw to ground the system.
7. Carefully place the gearcase assembly back onto motor assembly. Secure the gearcase assembly with two of the gearcase screws into the front of the new left housing half.
8. Take time to make sure that all components are back in place. Press all wires firmly into traps. Be sure the LED, PCBA, switch assembly and battery connector block are squarely and firmly in place. Be sure the fwd./rev. shuttle functions properly and that the shuttle spring is in place.
9. Gently put the right housing half back in place and check for any interferences prior to securing with the six handle screws and two remaining gearcase screws. Insert housing clip.