



SERVICE PARTS LIST

BULLETIN NO.
54-06-2355

SPECIFY CATALOG NO. AND SERIAL NO. WHEN ORDERING PARTS		REVISED BULLETIN	DATE
CORDLESS M12™ LED STICK LIGHT			Feb. 2013
CATALOG NO. 2351-20	STARTING SERIAL NO. F29A	WIRING INSTRUCTION	

00
0

EXAMPLE:
Component Parts (Small #) Are Included
When Ordering The Assembly (Large #).

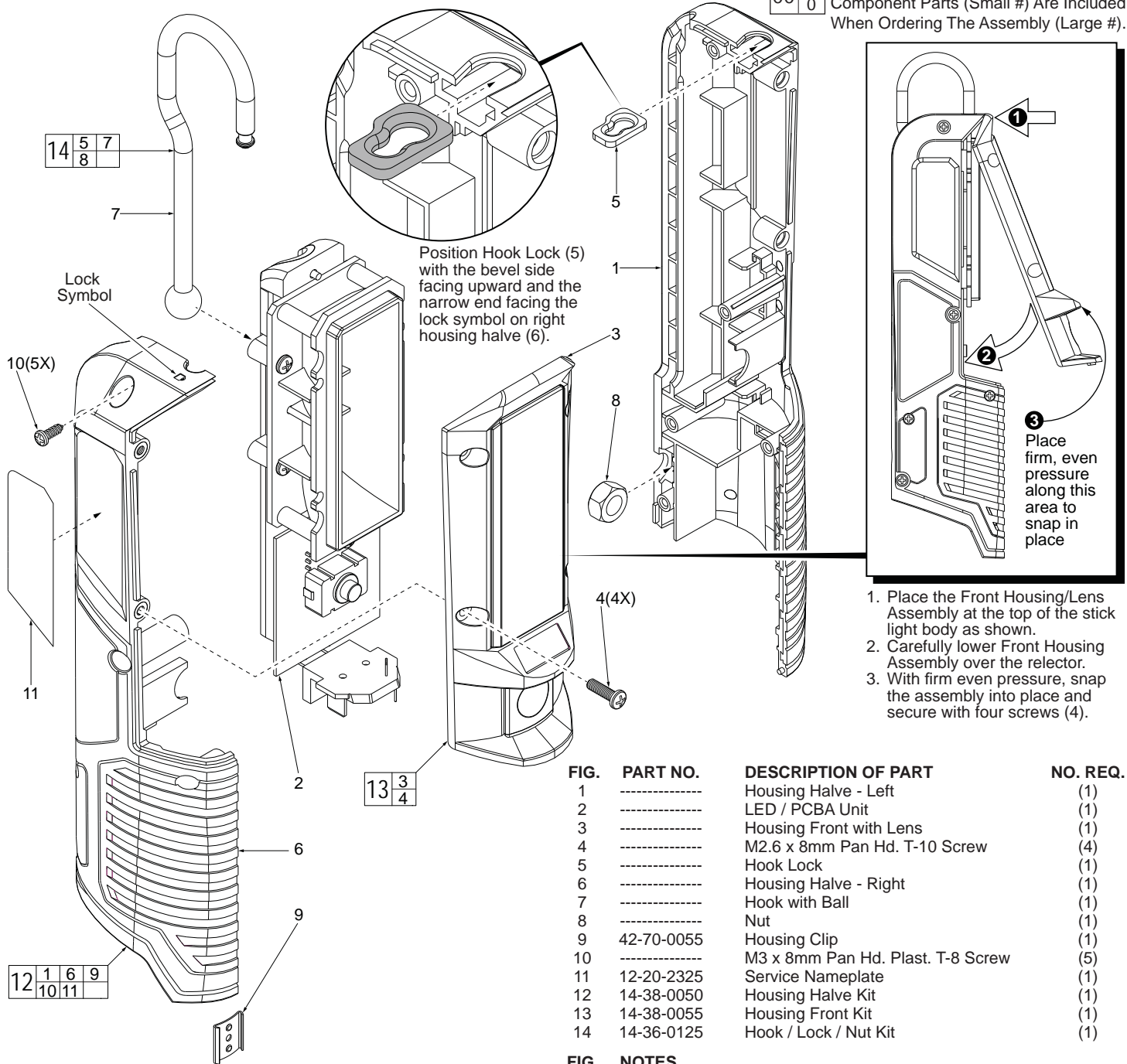

1. Place the Front Housing/Lens Assembly at the top of the stick light body as shown.
2. Carefully lower Front Housing Assembly over the relector.
3. With firm even pressure, snap the assembly into place and secure with four screws (4).

FIG.	PART NO.	DESCRIPTION OF PART	NO. REQ.
1	-----	Housing Half - Left	(1)
2	-----	LED / PCBA Unit	(1)
3	-----	Housing Front with Lens	(1)
4	-----	M2.6 x 8mm Pan Hd. T-10 Screw	(4)
5	-----	Hook Lock	(1)
6	-----	Housing Half - Right	(1)
7	-----	Hook with Ball	(1)
8	-----	Nut	(1)
9	42-70-0055	Housing Clip	(1)
10	-----	M3 x 8mm Pan Hd. Plast. T-8 Screw	(5)
11	12-20-2325	Service Nameplate	(1)
12	14-38-0050	Housing Halve Kit	(1)
13	14-38-0055	Housing Front Kit	(1)
14	14-36-0125	Hook / Lock / Nut Kit	(1)

FIG. NOTES
4,10 Care must be used when securing fasteners in tool. To prevent stripping do not over tighten. It is not recommended to use power tools, hand tighten only. Torque screws #4 to 5-7 in/lbs (6-8 kg/cm). Torque screws #10 to 3-4 in/lbs (3.5-4.5 kg/cm).

22 A clean, dry surface is essential for proper performance for any adhesive system. The area intended for application of any adhesive label or nameplate must be prepared by cleaning with isopropyl alcohol. The solvent is to be applied with a clean, lint free applicator and the surface allowed to dry before applying the label or nameplate.