



# SERVICE PARTS LIST

**BULLETIN NO.**  
54-30-0201

SPECIFY CATALOG NO. AND SERIAL NO. WHEN ORDERING PARTS		REVISED BULLETIN 54-30-0201	DATE May '82
<b>MAG STAND CONTROL PANEL</b>			
<b>CATALOG NO. 23-35-0101</b>	STARTING SERIAL NO.	WIRING INSTRUCTION 115 V 58-01-0900 230 V 58-01-0905	

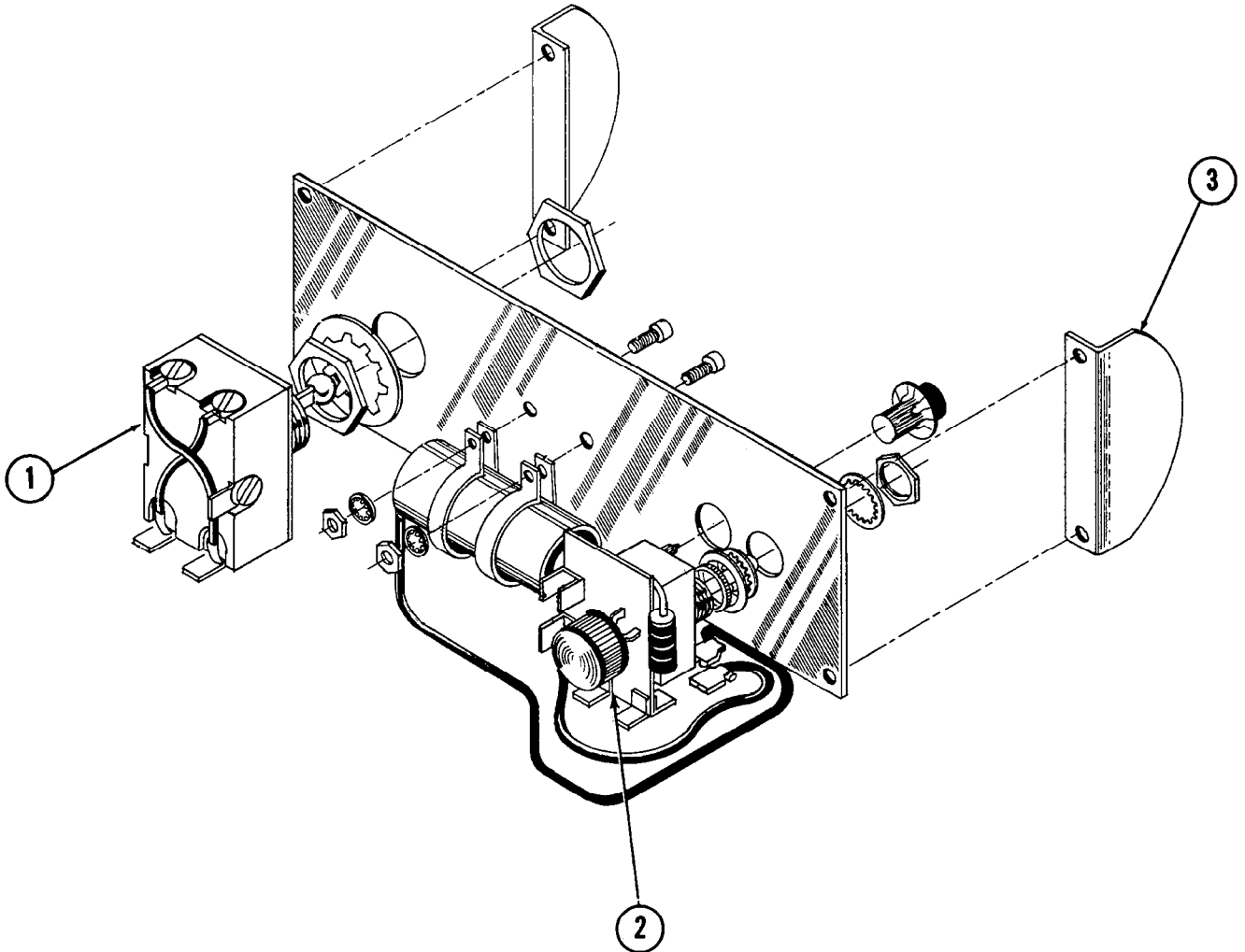

FIG.	PART NO.	DESCRIPTION OF PART	NO. REQ.
1	23-66-0340	Switch (With Fasteners)	
2	14-46-0380	Control Assembly	
3	43-54-0170	Panel Guard	(2)