

Cordless Drill Driver - F 012 223 600 - 2236

Item	Part Number	Description	Illustration	Price	Quantity	Price Group
1	2 610 358 578	Housing	1	-,-	1	21
2/1	2 610 351 015	Toothed Gear	1	-,-	1	11
4	2 610 968 740	Switch	1	-,-	1	22
21	2 610 351 016	Toothed Gear	1	-,-	6	11
22	2 610 351 023	Support	1	-,-	1	11
23	2 610 352 624	Lever	1	-,-	1	11
25	2 610 907 640	Chuck	1	-,-	1	30
26	2 610 351 048	Plate	1	-,-	1	15
27	2 610 351 049	Plate	1	-,-	1	16
29	2 610 358 560	Support	1	-,-	2	11
32	2 610 351 046	Support	1	-,-	1	13
60	2 610 026 126	Washer	1	-,-	1	11
61	2 610 068 005	Screw	1	-,-	1	11
63	2 610 351 011	Shim washer	1	-,-	1	12
64	2 610 351 034	Bearing	1	-,-	2	13
65	2 610 354 729	Washer	1	-,-	2	11
66	2 610 904 751	Support	1	-,-	1	11
67	2 610 908 334	Toothed Gear	1	-,-	1	13
91	2 610 902 304	Battery 3.6V	1	-,-	2	-
101	2 610 315 386	Screw ST3,9x19	1	-,-	5	11
651	2 610 902 302	Battery Charger 120V	1	-,-	1	33
653	2 610 315 835	Key	1	-,-	1	19
802	2 610 991 892	Motor 7,2V	1	-,-	1	37
824	2 610 904 752	Axle	1	-,-	1	22

Illustration - Type E

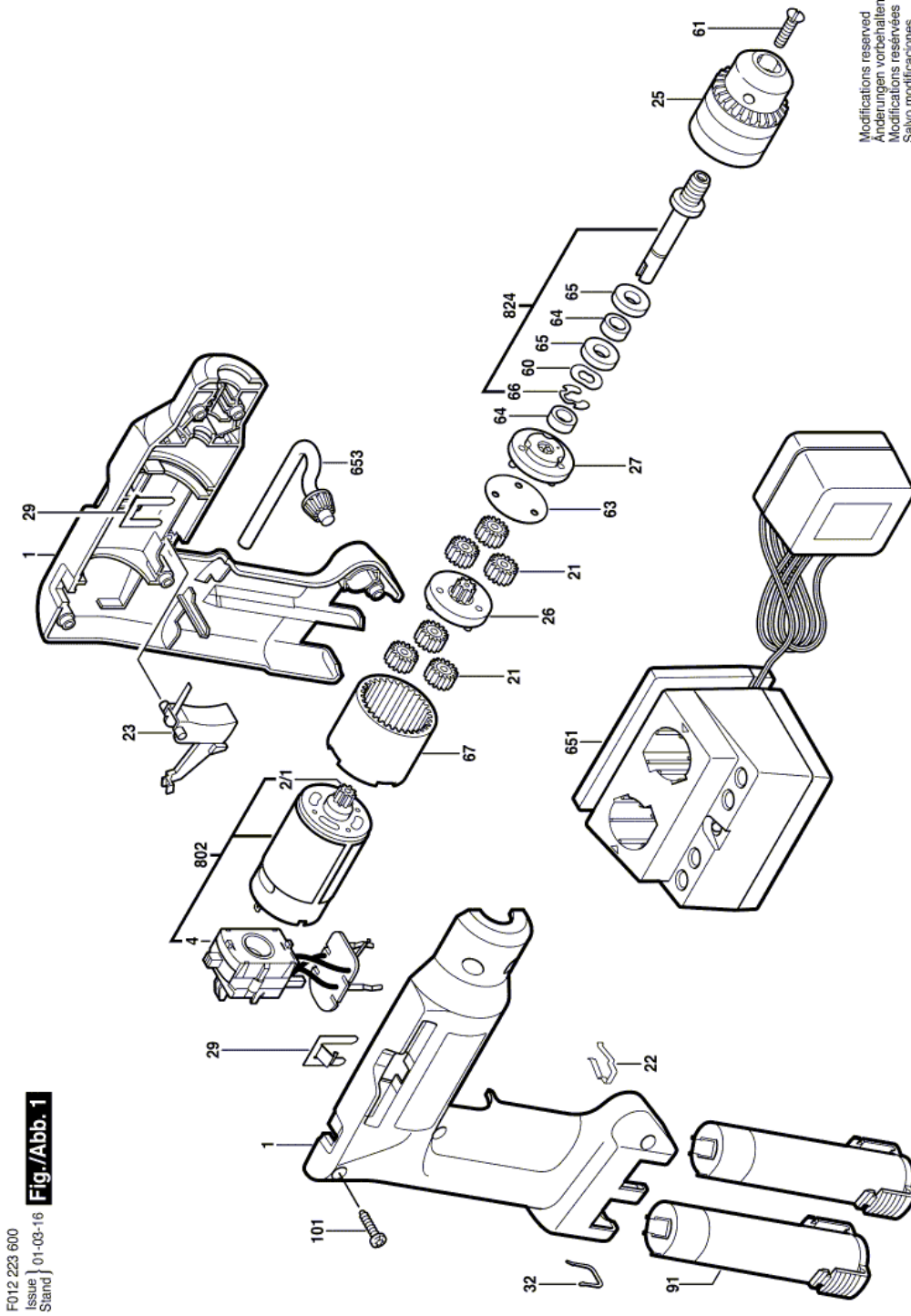

Information subject to change without further notice.