



# SERVICE PARTS LIST

**BULLETIN NO.**  
**55-12-1302**

SPECIFY CATALOG NO. AND SERIAL NO. WHEN ORDERING PARTS		REVISED BULLETIN	DATE
<b>SUPER HOLE-SHOOTER</b>			May '91
CATALOG NO. 1854-3	SERIAL NUMBER 567-145000	WIRING INSTRUCTION <b>58-01-0940</b>	

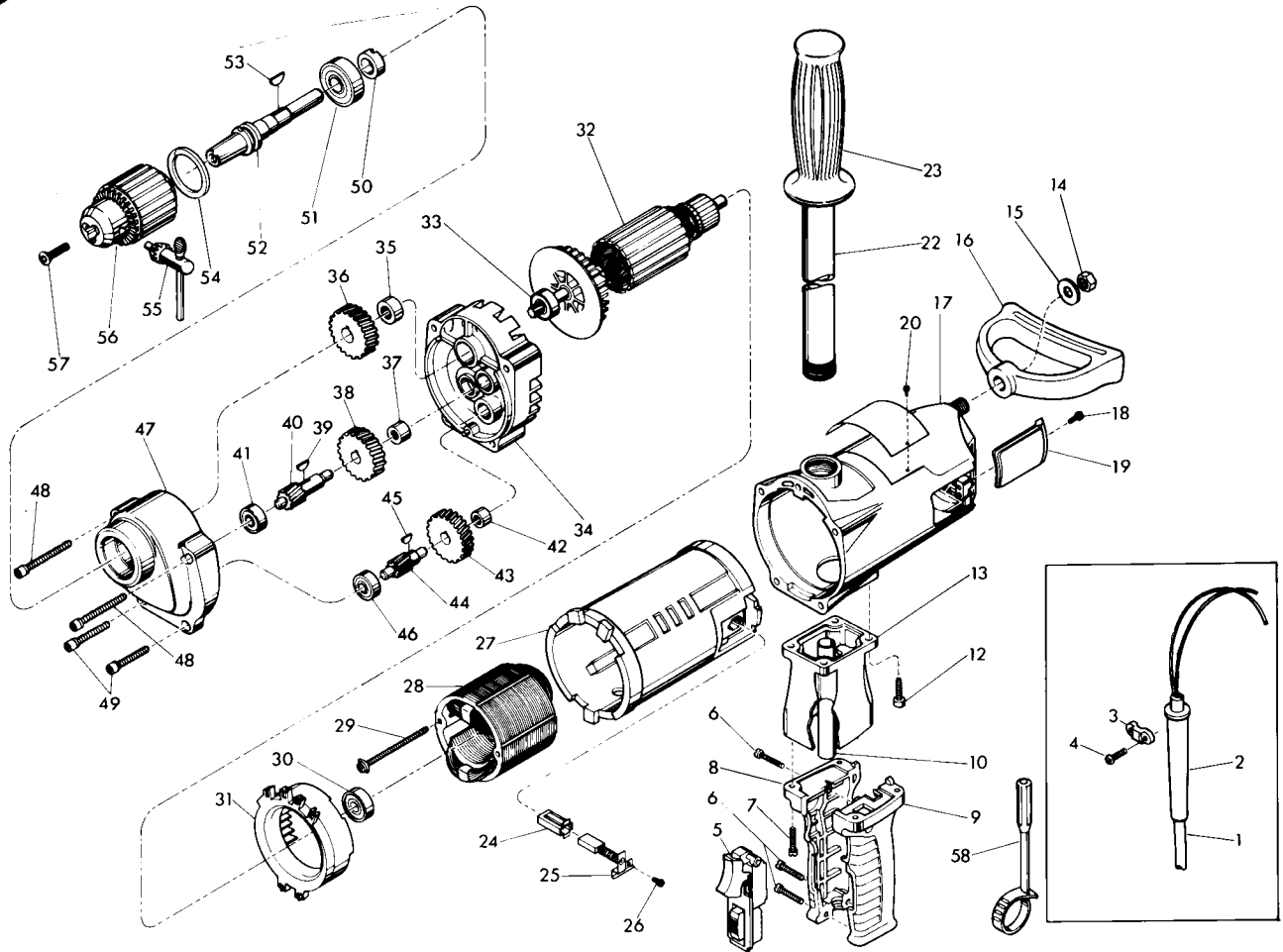

FIG.	PART NO.	DESCRIPTION OF PART	NO. REQ.
1	22-64-2230	Cord Set	(1)
2	44-76-0140	Cord Protector	(1)
3	31-17-0156	Cord Clamp	(1)
4	06-82-7270	8-16 x 5/8" Slotted Torx Plastite Screw	(2)
5	23-66-1420	Switch	(1)
6	06-82-7326	8-16 x 1" Slotted Torx Plastite Screw	(3)
7	06-82-5358	12-24x3/4" Pan Hd. Taptite Screw	(4)
8	31-44-1440	Right Handle Half	(1)
9	31-44-1445	Left Handle Half	(1)
10	23-16-1440	Insulating Tube	(1)
12	06-95-5645	1/4-20 x 3/4" Pan Hd. Taptite Screw	(4)
13	28-86-1611	Handle Spacer	(1)
14	06-55-2850	1/2-13 Hex Nut	(1)
15	45-88-7150	Thrust Washer	(1)
16	31-44-1450	Spade Handle	(1)
17	28-50-6365	Motor Housing	(1)
	06-14-0010	1/2x13x1-3/8" Hex Hd. Bolt (Included)	(1)
18	06-82-7252	8-32x3/8" Slotted Pan Hd. Taptite Screw	(2)
19	22-32-0350	Brush Cover	(2)
20	06-85-0200	Nameplate Screw	(2)
22	43-62-0121	Pipe Handle	(1)
23	43-62-0246	Handle Grip	(1)
24	22-20-0680	Brush Tube	(2)
25	22-18-0706	Carbon Brush Assembly	(2)
26	06-82-8835	8-32x5/16" Pan Torx Sems	(2)
27	23-16-1420	Insulated Housing	(1)
28	18-76-0310	240 V. Field	(1)
29	06-82-9072	10-24x2-1/8" Pan Hd. Sems	(2)
30	02-04-1041	Ball Bearing	(1)
31	2-14-0291	Baffle	(1)
32	16-76-0340	240 V. Armature	(1)
	22-84-0790	Fan (included with Item 32)	(1)
33	02-04-1229	Ball Bearing	(1)
34	14-13-0240	Diaphragm	(1)
	06-65-1155	Pin (Included)	(1)

FIG.	PART NO.	DESCRIPTION OF PART	NO. REQ.
35	02-50-4040	Needle Bearing	(1)
36	32-75-1001	Spindle Gear	(1)
37	02-50-2450	Needle Bearing	(1)
38	32-44-1181	Intermediate Gear	(1)
39	06-42-1600	Woodruff Key	(1)
40	36-66-0501	Intermediate Pinion Shaft	(1)
41	02-04-0910	Ball Bearing	(1)
42	02-50-2450	Needle Bearing	(1)
43	32-40-1001	Intermediate Gear	(1)
44	36-66-2601	Intermediate Pinion Shaft	(1)
45	06-42-1200	Woodruff Key	(1)
46	02-04-0910	Ball Bearing	(1)
47	28-14-0401	Gear Case	(1)
48	06-82-8440	1/4-20x2-1/2" Fil. Taptite Torx Sems	(2)
49	06-82-8330	1/4-20x1-7/8" Fil. Taptite Torx Sems	(2)
50	45-36-0200	Spacer	(1)
51	02-04-2031	Ball Bearing	(1)
52	38-50-5500	Reversing Spindle	(1)
53	06-42-2400	Woodruff Key	(1)
54	34-80-3450	Retaining Ring	(1)
55	48-66-3160	Chuck Key	(1)
56	48-66-2085	Chuck (Includes Fig. No. 55)	(1)
57	06-81-3100	5/16-18x1" Socket Hd. Screw	(1)
58	48-66-4020	Chuck Key Holder	(1)

### FIG. LUBRICATION

47 7-3/4 Oz. "E" Grease, No. 49-08-4121.

### FIG. NOTES

- 12 Tighten one screw until lockwasher is touching handle spacer. Tighten the diagonally opposite screw (70-80 lbs./in. on new motor housing) and then sequentially tighten the other screws.

48,49 Apply type 242 Blue Loctite.

**MILWAUKEE ELECTRIC TOOL CORPORATION**  
13135 W. LISBON RD., BROOKFIELD, WI 53005