

**ILLUSTRATED PARTS LIST**

**MODEL NUMBER 1827EXLT**

**PRODUCT NUMBER 961 93 00-77**

**MFG. ID. NUMBER 96193007700**

# REPAIR PARTS

# AUGER HOUSING / IMPELLER ASSEMBLY

SNOW THROWER - MODEL NO. 1827EXLT (96193007700), PRODUCT NO. 961 93 00-77

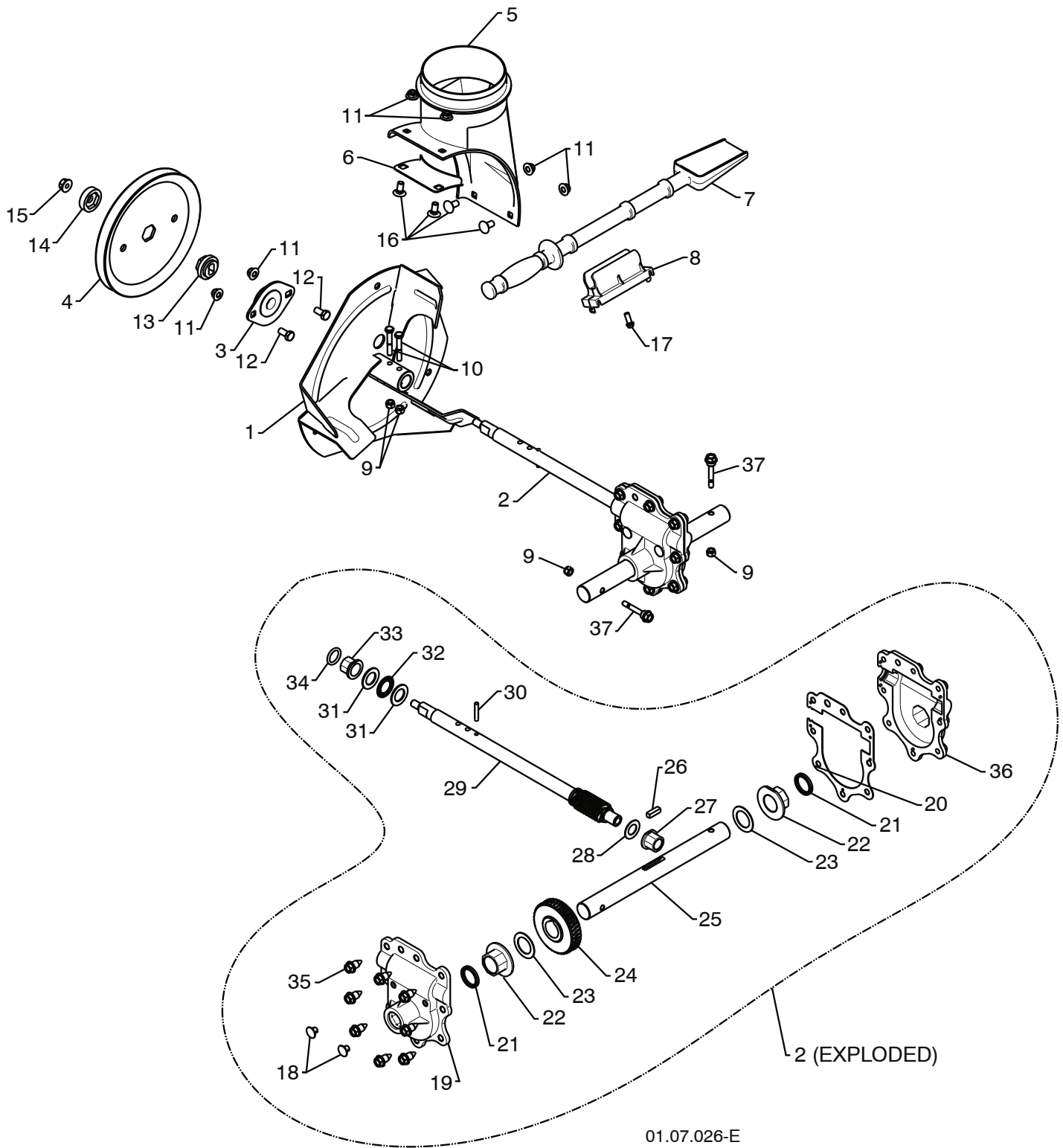

**NOTE:** All component dimensions given in U.S. inches. 1 inch = 25.4 mm  
**IMPORTANT:** Use only Original Equipment Manufacturer (O.E.M.) replacement parts.  
Failure to do so could be hazardous, damage your snow thrower and void your warranty.

## REPAIR PARTS

## AUGER HOUSING / IMPELLER ASSEMBLY

SNOW THROWER - MODEL NO. **1827EXLT** (96193007700), PRODUCT NO. 961 93 00-77

KEY NO.	PART NO.	DESCRIPTION
1	532 18 41-05	IMPELLER
2	532 42 71-48	GEARBOX ASSEMBLY
3	532 18 89-09	BEARING
4	532 42 71-46	IMPELLER PULLEY
5	532 44 24-38	DISCHARGE BASE
6	532 18 40-95	CORNER BRACKET
7	532 19 21-99	CLEAN OUT TOOL
8	532 40 54-00	TOOL CLIP
9	873 80 04-00	NUT 1/4-20
10	874 78 04-26	SCREW 1/4-20 X .625
11	532 42 79-42	NUT 5/16-18
12	532 16 31-83	SCREW 5/16-18 X .625
13	532 42 71-45	IMPELLER HUB
14	532 42 71-54	IMPELLER SLEEVE
15	873 90 06-00	NUT 3/8-16
16	532 18 03-55	CARRIAGE BOLT
17	532 19 41-89	SCREW 13-16 X .625
18	532 40 77-60	PLUG
19	532 42 73-02	GEARBOX COVER RH
20	532 42 73-45	GASKET
21	532 40 77-70	SEAL
22	532 40 77-62	BEARING
23	532 17 46-97	THRUST WASHER 1.00
24	532 40 77-63	WORM GEAR
25	532 40 77-64	AUGER SHAFT
26	532 18 92-82	SQUARE KEY
27	532 40 77-58	BEARING
28	532 17 46-83	THRUST WASHER
29	532 42 71-47	IMPELLER SHAFT
30	532 18 42-05	ROLL PIN
31	532 17 46-81	THRUST WASHER
32	532 17 46-84	THRUST BEARING
33	532 40 77-69	BEARING
34	532 40 77-68	O-RING
35	532 40 77-67	SCREW 5/16-18 X .750
36	532 42 73-17	GEARBOX COVER LH
37	532 19 20-90	SHEAR BOLT

**NOTE:** All component dimensions given in U.S. inches. 1 inch = 25.4 mm

**IMPORTANT:** Use only Original Equipment Manufacturer (O.E.M.) replacement parts. Failure to do so could be hazardous, damage your snow thrower and void your warranty.

# REPAIR PARTS

# AUGER HOUSING / IMPELLER ASSEMBLY

SNOW THROWER - MODEL NO. 1827EXLT (96193007700), PRODUCT NO. 961 93 00-77

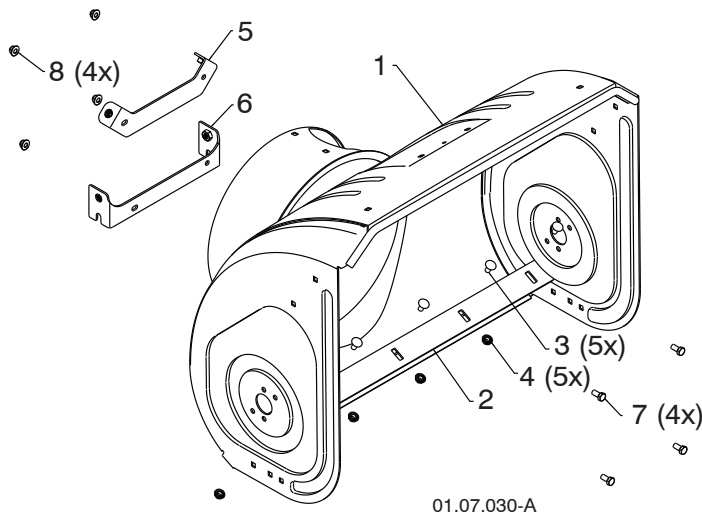

KEY NO.	PART NO.	DESCRIPTION
1	532 44 36-84	AUGER HOUSING 27
2	532 41 53-71	SCRAPPER BAR
3	872 27 05-05	CARRIAGE BOLT 5/16 – 18 X .625
4	532 15 53-77	NUT 5/16 – 18
5	532 44 32-90	UPPER BRACKET ASSEMBLY
6	532 44 32-91	LOWER BRACKET ASSEMBLY
7	532 16 31-83	CAPSCREW 5/16 – 18 X .625
8	532 42 79-42	NUT NYLOCK 5/16 – 18

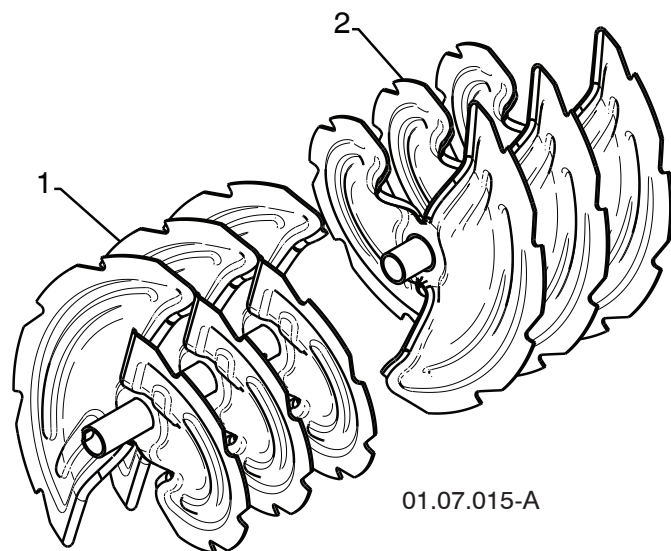

KEY NO.	PART NO.	DESCRIPTION
1	532 42 96-57	AUGER ASSEMBLY 27 LH
2	532 42 69-58	AUGER ASSEMBLY 27 RH

**NOTE:** All component dimensions given in U.S. inches. 1 inch = 25.4 mm  
**IMPORTANT:** Use only Original Equipment Manufacturer (O.E.M.) replacement parts.  
 Failure to do so could be hazardous, damage your snow thrower and void your warranty.

# REPAIR PARTS

# AUGER HOUSING / IMPELLER ASSEMBLY

SNOW THROWER - MODEL NO. 1827EXLT (96193007700), PRODUCT NO. 961 93 00-77

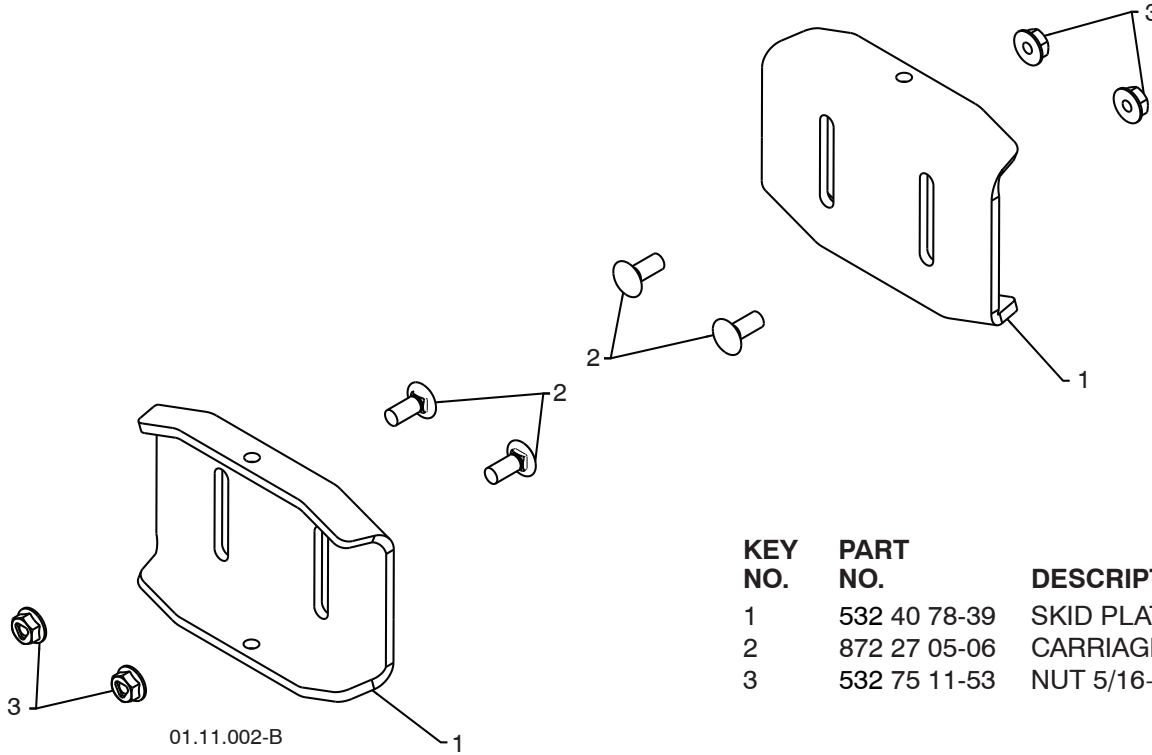

KEY NO.	PART NO.	DESCRIPTION
1	532 40 78-39	SKID PLATE
2	872 27 05-06	CARRIAGE BOLT 5/16-18 X .750
3	532 75 11-53	NUT 5/16-18

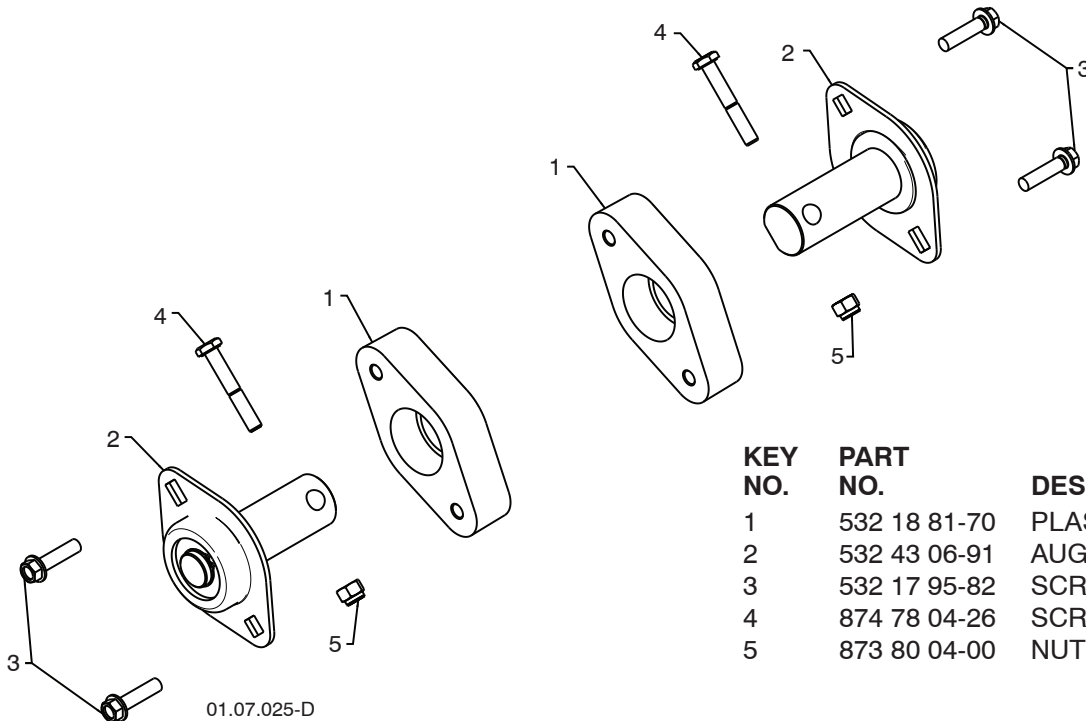

KEY NO.	PART NO.	DESCRIPTION
1	532 18 81-70	PLASTIC RETAINER
2	532 43 06-91	AUGER BALL BEARING
3	532 17 95-82	SCREW 5/16-18 x 1.00
4	874 78 04-26	SCREW 1/4-20 x .625
5	873 80 04-00	NUT 1/4-20

**NOTE:** All component dimensions given in U.S. inches. 1 inch = 25.4 mm  
**IMPORTANT:** Use only Original Equipment Manufacturer (O.E.M.) replacement parts.  
 Failure to do so could be hazardous, damage your snow thrower and void your warranty.

# REPAIR PARTS

# AUGER HOUSING / IMPELLER ASSEMBLY

SNOW THROWER - MODEL NO. 1827EXLT (96193007700), PRODUCT NO. 961 93 00-77

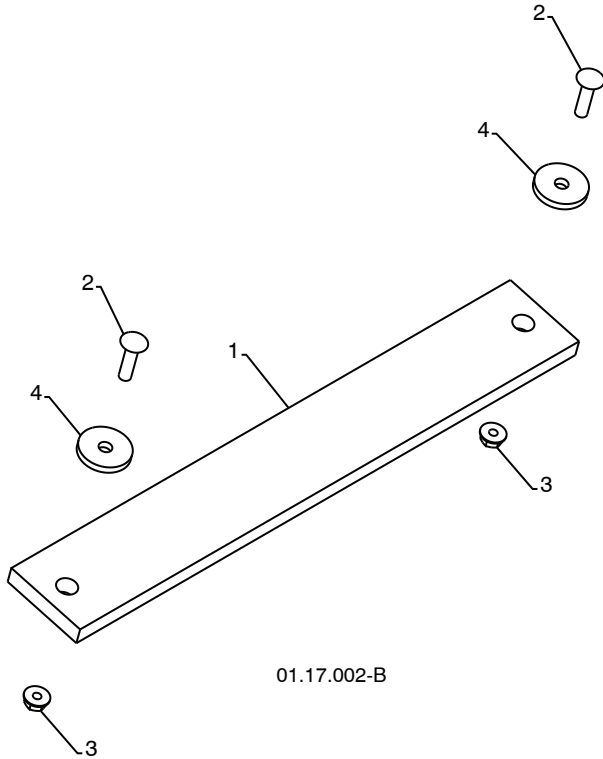

01.17.002-B

KEY NO.	PART NO.	DESCRIPTION
1	532 18 25-15	WEIGHT BAR
2	872 11 05-10	CARRIAGE BOLT 5/16-18 X 1.25
3	532 75 11-53	NUT 5/16-18
4	819 11 22-06	WASHER

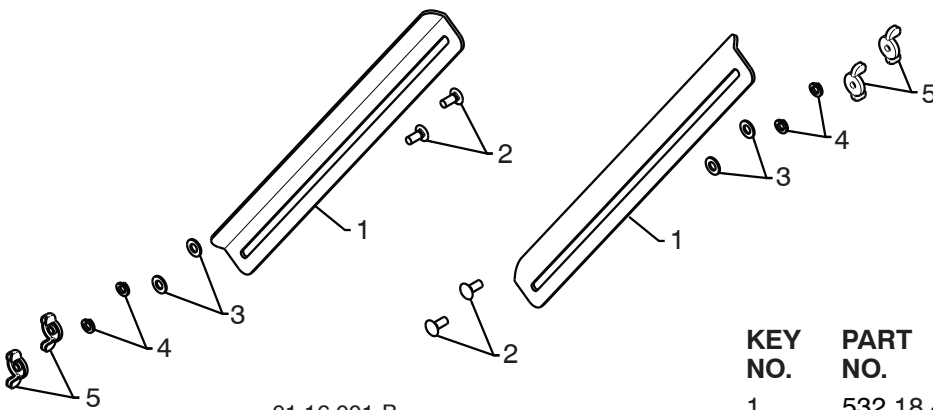

01.16.001-B

KEY NO.	PART NO.	DESCRIPTION
1	532 18 47-47	DRIFT CUTTER BAR
2	872 27 05-06	CARRIAGE BOLT 5/16-18 X .750
3	532 17 92-46	PLASTIC WASHER
4	810 04 05-00	LOCKWASHER 5/16
5	532 12 86-38	NUT 5/16-18

**NOTE:** All component dimensions given in U.S. inches. 1 inch = 25.4 mm  
**IMPORTANT:** Use only Original Equipment Manufacturer (O.E.M.) replacement parts.  
 Failure to do so could be hazardous, damage your snow thrower and void your warranty.

# REPAIR PARTS

# CONTROL PANEL / DISCHARGE CHUTE

SNOW THROWER - MODEL NO. **1827EXLT** (96193007700), PRODUCT NO. 961 93 00-77

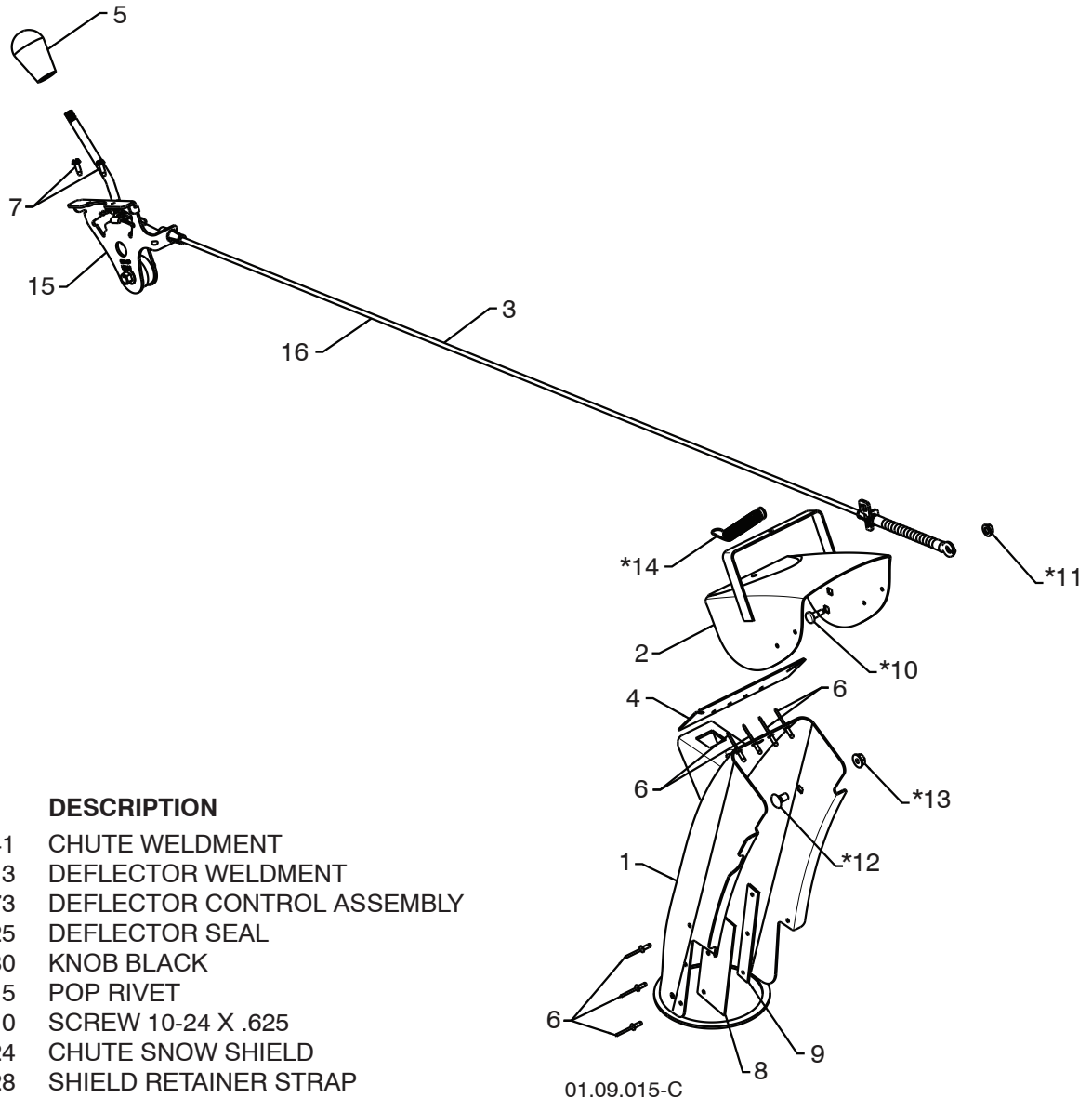

KEY NO.	PART NO.	DESCRIPTION
1	532 44 40-41	CHUTE WELDMENT
2	532 18 41-13	DEFLECTOR WELDMENT
3	532 42 06-73	DEFLECTOR CONTROL ASSEMBLY
4	532 42 03-25	DEFLECTOR SEAL
5	532 41 42-80	KNOB BLACK
6	532 12 84-15	POP RIVET
7	817 50 10-10	SCREW 10-24 X .625
8	532 43 03-24	CHUTE SNOW SHIELD
9	532 42 17-28	SHIELD RETAINER STRAP
*10	532 17 98-29	SHOULDER BOLT 1/4-20 X .375
*11	532 19 17-30	NUT 1/4-20
*12	872 25 05-05	CARRIAGE BOLT 3/8-16 X .625
*13	532 75 11-53	NUT 5/16-18
*14	532 18 45-05	DEFLECTOR SPRING
15	532 42 06-79	(SERVICE PART) DEFLECTOR CONTROL
16	532 42 06-72	(SERVICE PART) DEFLECTOR CABLE BLACK

## NOTE:

1. ALL ITEMS INDICATED WITH AN \* ARE PROVIDED IN THE BAG OF ITEMS SHIPPED LOOSE WITH PRODUCT.
2. ITEMS 15 AND 16 ARE SERVICE PART NUMBERS TO ALLOW PURCHASE OF INDIVIDUAL ITEMS IF NECESSARY.

**NOTE:** All component dimensions given in U.S. inches. 1 inch = 25.4 mm  
**IMPORTANT:** Use only Original Equipment Manufacturer (O.E.M.) replacement parts.  
 Failure to do so could be hazardous, damage your snow thrower and void your warranty.

# REPAIR PARTS

# CONTROL PANEL / DISCHARGE CHUTE

SNOW THROWER - MODEL NO. 1827EXLT (96193007700), PRODUCT NO. 961 93 00-77

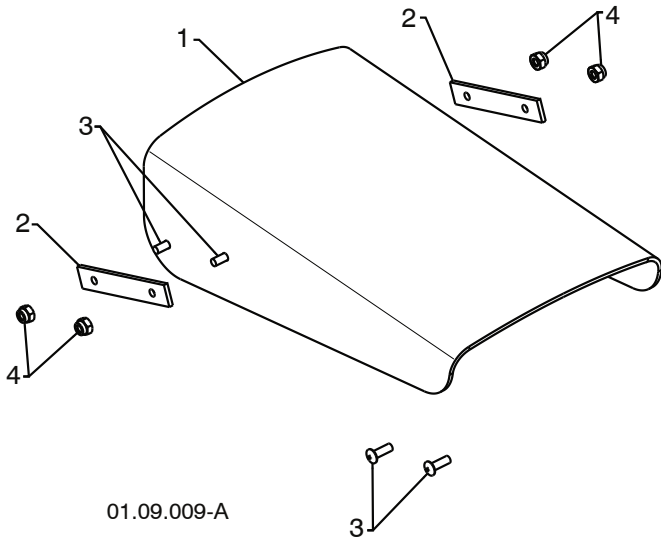

KEY NO.	PART NO.	DESCRIPTION
1	532 42 11-38	SHIELD DEFLECTOR
2	532 42 32-47	STRAP
3	532 18 22-27	SCREW 8-32 X .50
4	532 18 22-28	NUT 8-32

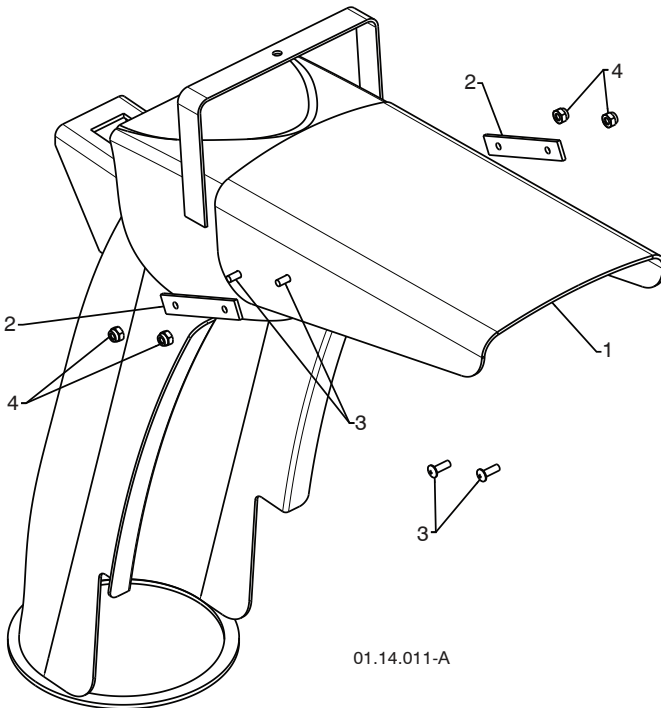

KEY NO.	PART NO.	DESCRIPTION
1	532 42 11-38	SHIELD DEFLECTOR
2	532 42 32-47	STRAP
3	532 18 22-27	SCREW 8-32 X .50
4	532 18 22-28	NUT 8-32

**NOTE:** All component dimensions given in U.S. inches. 1 inch = 25.4 mm  
**IMPORTANT:** Use only Original Equipment Manufacturer (O.E.M.) replacement parts.  
 Failure to do so could be hazardous, damage your snow thrower and void your warranty.



# REPAIR PARTS

# CONTROL PANEL / DISCHARGE CHUTE

SNOW THROWER - MODEL NO. **1827EXLT** (96193007700), PRODUCT NO. 961 93 00-77

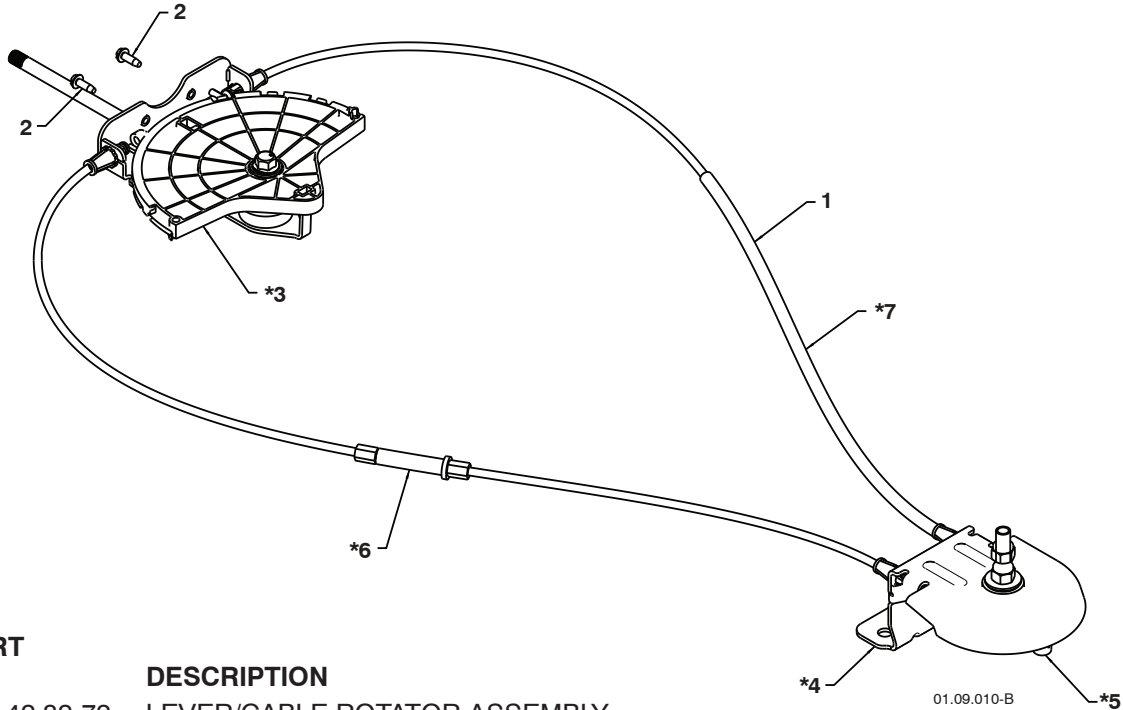

KEY NO.	PART NO.	DESCRIPTION
1	532 42 82-72	LEVER/CABLE ROTATOR ASSEMBLY
2	817 50 10-10	SCREW 10-24 X .625
*3	532 42 06-78	ROTATOR HEAD
*4	532 40 59-32	ROTATOR PIVOT BRACKET
*5	532 42 06-75	PULLEY PIVOT
*6	532 42 82-73	CABLE ASSEMBLY ADJUSTABLE
*7	532 42 83-10	CABLE ASSEMBLY HEAT SHIELD

**NOTES:**

1. ITEMS INDICATED WITH AN \* ARE LISTED AS REFERENCE FOR SERVICE PARTS ONLY.

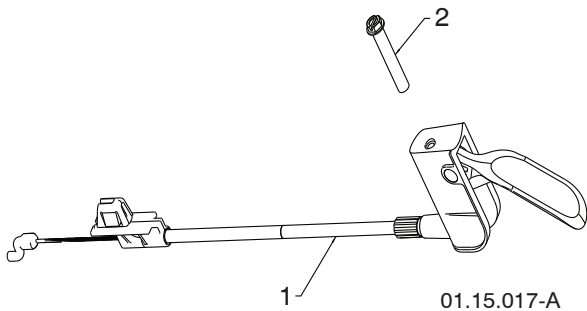

KEY NO.	PART NO.	DESCRIPTION
1	532 43 86-29	STEER CABLE
2	874 04 10-24	SCREW 10-24 X 1.50

**NOTE:** All component dimensions given in U.S. inches. 1 inch = 25.4 mm  
**IMPORTANT:** Use only Original Equipment Manufacturer (O.E.M.) replacement parts. Failure to do so could be hazardous, damage your snow thrower and void your warranty.

# REPAIR PARTS

# HANDLES

SNOW THROWER - MODEL NO. 1827EXLT (96193007700), PRODUCT NO. 961 93 00-77

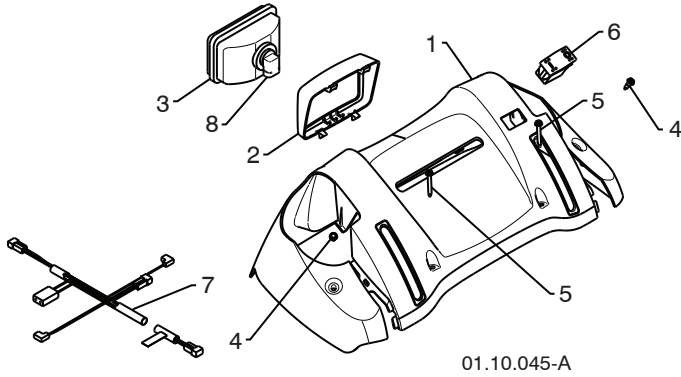

KEY NO.	PART NO.	DESCRIPTION
1	532 42 13-51	CONSOLE PANEL GRAY
2	532 42 14-48	HEADLIGHT BEZEL GRAY
3	532 17 86-66	HALOGEN HEADLIGHT
4	532 18 44-71	SHOULDER SCREW 10-24 X .625
5	532 17 52-62	SCREW 10-24 X 1.25
6	532 41 77-60	GRIP SWITCH
7	532 44 49-78	WIRE HARNESS
8	532 40 16-20	BULB

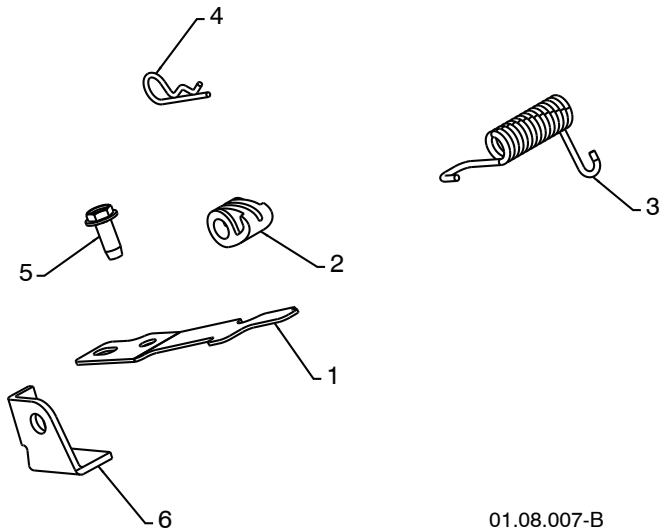

KEY NO.	PART NO.	DESCRIPTION
1	532 41 62-88	INTERLOCK SPRING
2	532 41 45-72	INTERLOCK CAM
3	532 17 88-31	TORSION SPRING
4	532 16 96-75	RETAINER
5	817 06 04-10	SCREW 1/4-20 X .625
6	532 42 18-14	INTERLOCK STOP

**NOTE:** All component dimensions given in U.S. inches. 1 inch = 25.4 mm  
**IMPORTANT:** Use only Original Equipment Manufacturer (O.E.M.) replacement parts. Failure to do so could be hazardous, damage your snow thrower and void your warranty.

# REPAIR PARTS

# HANDLES

SNOW THROWER - MODEL NO. **1827EXLT** (96193007700), PRODUCT NO. 961 93 00-77

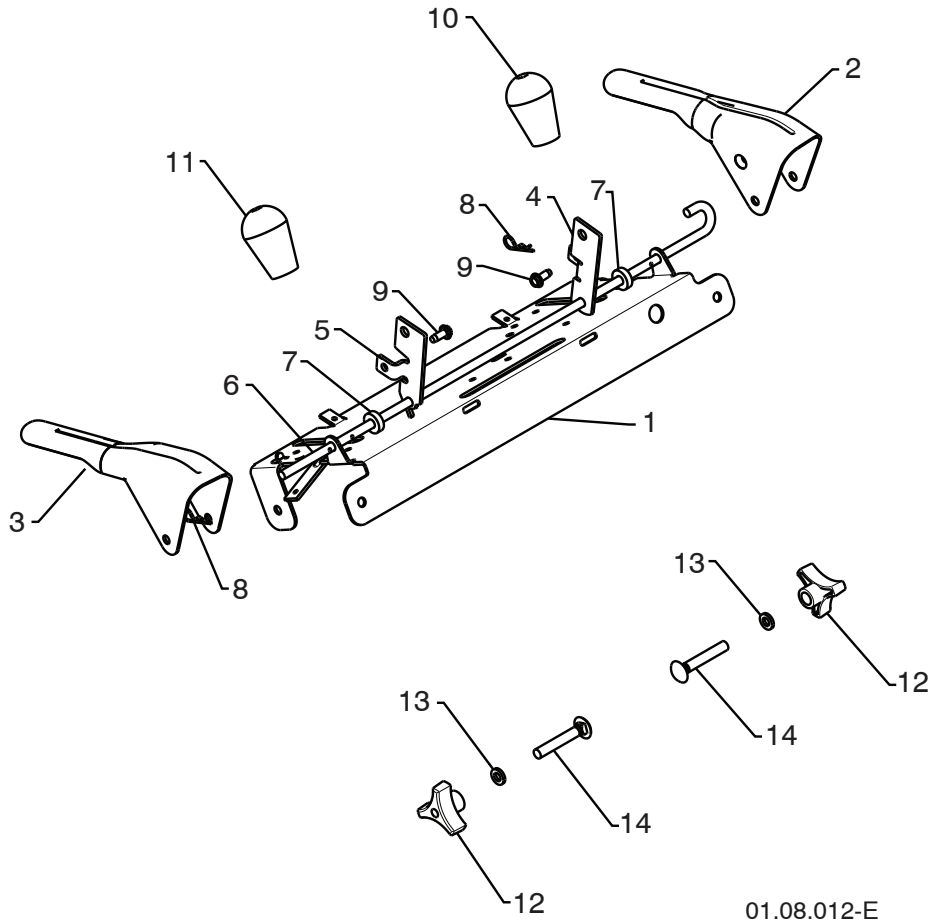

KEY NO.	PART NO.	DESCRIPTION
1	532 41 55-39	CONTROL PANEL
2	532 42 91-50	CONTROL LEVER LH
3	532 42 91-51	CONTROL LEVER RH
4	532 41 55-46	TRACTION ROD ARM
5	532 42 90-98	IMPELLER ROD ARM
6	532 41 26-77	INTERLOCK ROD
7	532 42 16-13	SPACER
8	532 16 96-75	RETAINER
9	817 06 04-10	SCREW 1/4-20 X .62
10	532 41 42-80	KNOB BLACK
11	532 41 42-81	KNOB RED
12	532 17 88-99	HANDLE KNOB
13	819 13 13-16	WASHER 3/8
14	872 12 06-18	CARRIAGE BOLT 3/8-16 X 2.25

**NOTE:** All component dimensions given in U.S. inches. 1 inch = 25.4 mm  
**IMPORTANT:** Use only Original Equipment Manufacturer (O.E.M.) replacement parts. Failure to do so could be hazardous, damage your snow thrower and void your warranty.

# REPAIR PARTS

# HANDLES

SNOW THROWER - MODEL NO. 1827EXLT (96193007700), PRODUCT NO. 961 93 00-77

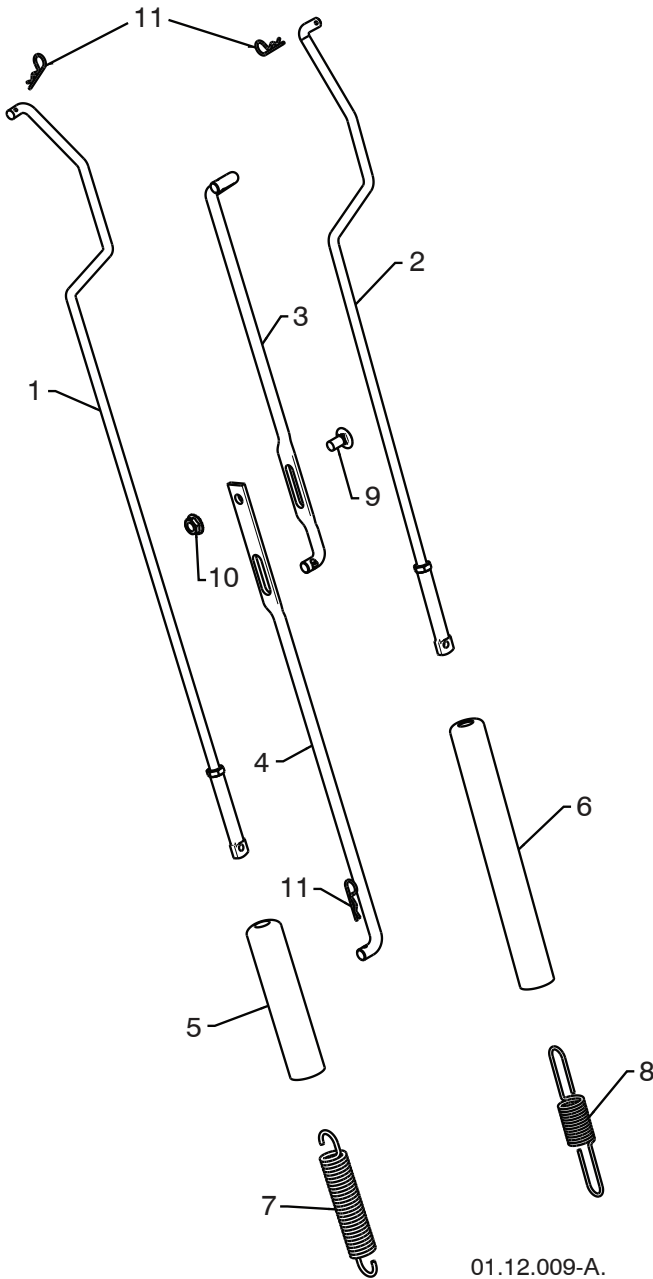

KEY NO.	PART NO.	DESCRIPTION
1	532 42 17-63	IMPELLER ROD ASSEMBLY
2	532 42 98-32	TRACTION ROD ASSEMBLY
3	532 18 77-82	SHIFTER ROD TOP
4	532 18 77-84	SHIFTER ROD BOTTOM
5	532 18 04-47	SPRING SLEEVE
6	532 19 20-91	SPRING SLEEVE
7	532 17 86-69	IMPELLER SPRING
8	532 18 09-26	TRACTION SPRING
9	872 27 05-05	CARRIAGE BOLT 5/16-18 X .750
10	532 15 53-77	NUT 5/16-18
11	532 16 96-75	RETAINER

**NOTE:** All component dimensions given in U.S. inches. 1 inch = 25.4 mm  
**IMPORTANT:** Use only Original Equipment Manufacturer (O.E.M.) replacement parts.  
Failure to do so could be hazardous, damage your snow thrower and void your warranty.

# REPAIR PARTS

# HANDLES

SNOW THROWER - MODEL NO. 1827EXLT (96193007700), PRODUCT NO. 961 93 00-77

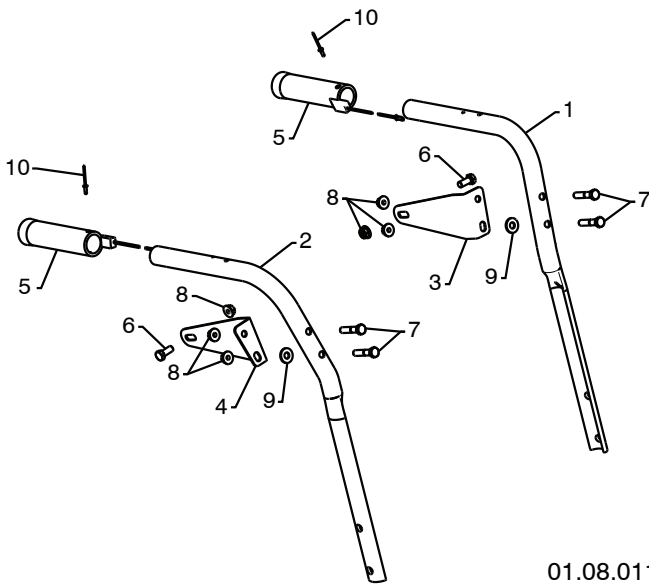

KEY NO.	PART NO.	DESCRIPTION
1	532 42 17-08	PLOW HANDLE LH
2	532 42 17-09	PLOW HANDLE RH
3	532 42 91-48	PANEL BRACKET LH
4	532 42 91-49	PANEL BRACKET RH
5	532 41 45-15	HEATED HANDLE GRIP
6	874 78 05-12	SCREW 5/16-18 X .750
7	874 78 05-24	SCREW 5/16-18 X 1.50
8	532 75 11-53	NUT 5/16-18
9	532 15 54-15	WASHER
10	532 17 87-75	POP RIVET 1/8

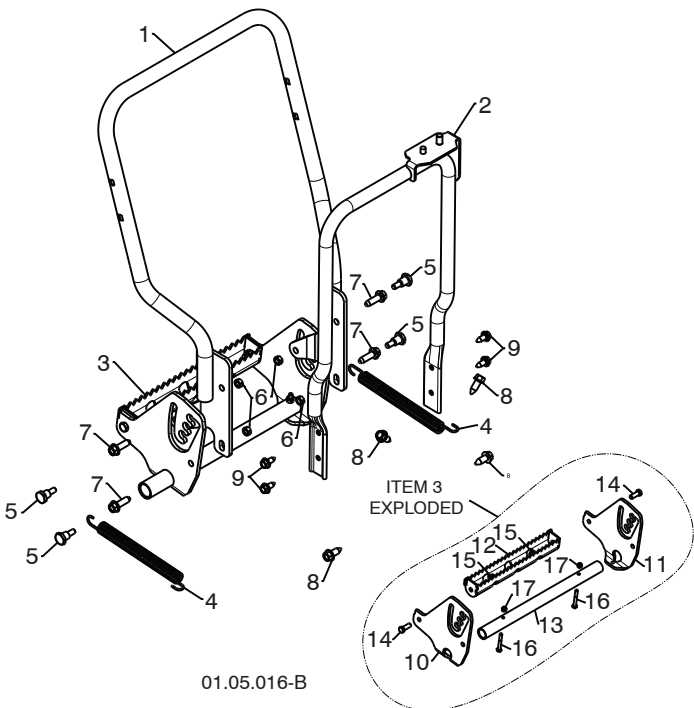

KEY NO.	PART NO.	DESCRIPTION
1	532 44 42-32	LOWER TUBE WELDMENT GRAY
2	532 44 36-17	PIVOT SUPPORT
3	532 44 35-55	FOOT ADJUST ASSEMBLY
4	532 44 32-48	EXTENSION SPRING
5	532 44 36-60	SHOULDER BOLT 5/16-18
6	873 93 05-00	LOCKNUT 5/16-18
7	817 06 06-20	SCREW 3/8-16 X 1.25
8	817 00 06-16	SCREW 3/8-16 X 1.00
9	817 00 05-10	SCREW 5/16-18 X .750
10	532 44 28-44	RIGHT GUIDE PLATE
11	532 44 28-45	LEFT GUIDE PLATE
12	532 44 28-46	FOOT ADJUST PEDAL
13	532 44 28-49	ANTI-ROTATE TUBE
14	874 78 06-16	CAPSCREW 3/8-16 X 1.00
15	873 80 06-00	NUT NYLOCK 3/8-16
16	847 46 04-32	CAPSCREW 1/4-20 X 2.00
17	873 80 04-00	NUT NYLOCK 1/4-20

**NOTE:** All component dimensions given in U.S. inches. 1 inch = 25.4 mm  
**IMPORTANT:** Use only Original Equipment Manufacturer (O.E.M.) replacement parts.  
 Failure to do so could be hazardous, damage your snow thrower and void your warranty.

# REPAIR PARTS

# DRIVE

SNOW THROWER - MODEL NO. 1827EXLT (96193007700), PRODUCT NO. 961 93 00-77

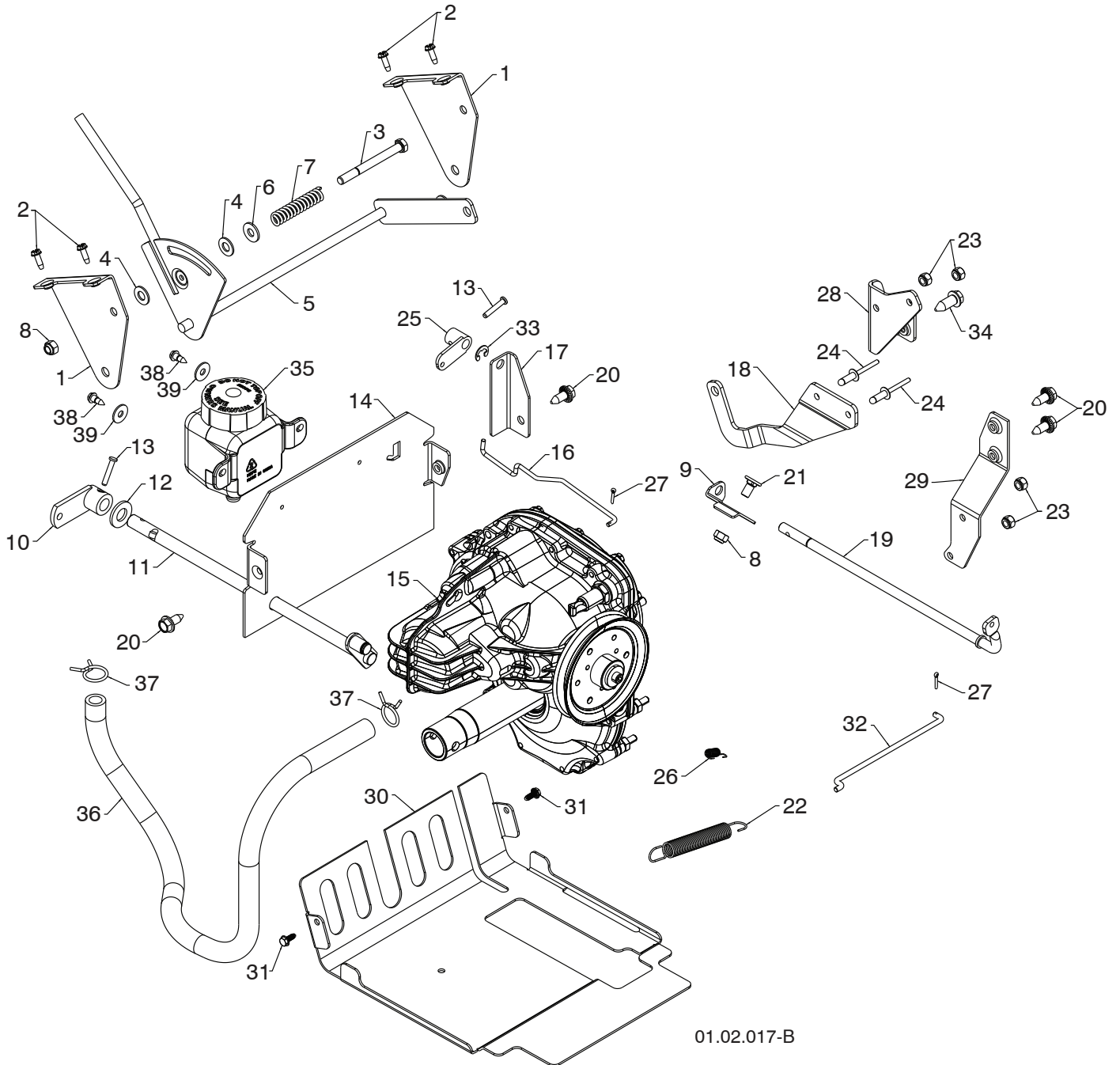

**NOTE:** All component dimensions given in U.S. inches. 1 inch = 25.4 mm  
**IMPORTANT:** Use only Original Equipment Manufacturer (O.E.M.) replacement parts.  
Failure to do so could be hazardous, damage your snow thrower and void your warranty.

**REPAIR PARTS****DRIVE****SNOW THROWER - MODEL NO. 1827EXLT (96193007700), PRODUCT NO. 961 93 00-77**

KEY NO.	PART NO.	DESCRIPTION
1	532 44 33-44	SHIFT BRACKET
2	817 50 10-10	SCREW 10-24 X .625
3	874 76 05-52	SCREW 5/16-18 X 3.25
4	532 17 92-46	PLASTIC WASHER
5	532 19 20-01	SHIFT ASSEMBLY
6	532 15 54-15	WASHER
7	532 19 21-95	FRICTION SPRING
8	873 80 05-00	NUT 5/16-18
9	532 42 98-03	FRONT CLUTCH BRACKET
10	532 44 31-91	CONTROL ARM
11	532 42 75-42	CONTROL SHAFT
12	532 18 89-06	WASHER
13	532 19 85-80	CLEVIS PIN
14	532 40 78-68	REAR PLATE
15	532 44 50-58	TRANSMISSION
16	532 19 32-56	ROD
17	532 42 98-05	REAR CLUTCH BRACKET
18	532 18 77-87	CONTROL ARM
19	532 19 82-51	CLUTCH SHAFT
20	532 42 88-67	SCREW 5/16-18 X .750
21	532 18 03-55	CARRIAGE BOLT 5/16-18 X .625
22	532 17 88-28	BRAKE SPRING
23	873 80 04-00	NUT 1/4-20
24	532 19 19-95	POP RIVET 1/4 X .475
25	532 19 82-49	CLUTCH ARM
26	532 19 28-73	TRACTION SPRING
27	532 70 02-79	RETAINER CLIP
28	532 40 78-58	ANTI-ROTATE BRACKET
29	532 41 47-71	TORQUE STRAP BRACKET
30	532 44 42-33	BOTTOM PAN
31	532 44 33-84	SCREW 10-32 X .500
32	532 19 82-50	CLUTCH ROD
33	532 42 82-88	E-RING .375
34	817 06 05-16	SCREW 5/16-18 X 1.00
35	574 81 13-01	REMOTE EXPANSION TANK
36	532 44 50-59	HOSE EXPANSION TANK
37	532 44 51-52	SPRING HOSE CLAMP .750
38	532 18 44-71	SHOULDER BOLT 10-24 X 6.25
39	532 05 38-47	WASHER

**NOTE:** All component dimensions given in U.S. inches. 1 inch = 25.4 mm

**IMPORTANT:** Use only Original Equipment Manufacturer (O.E.M.) replacement parts. Failure to do so could be hazardous, damage your snow thrower and void your warranty.

# REPAIR PARTS

# DRIVE

SNOW THROWER - MODEL NO. 1827EXLT (96193007700), PRODUCT NO. 961 93 00-77

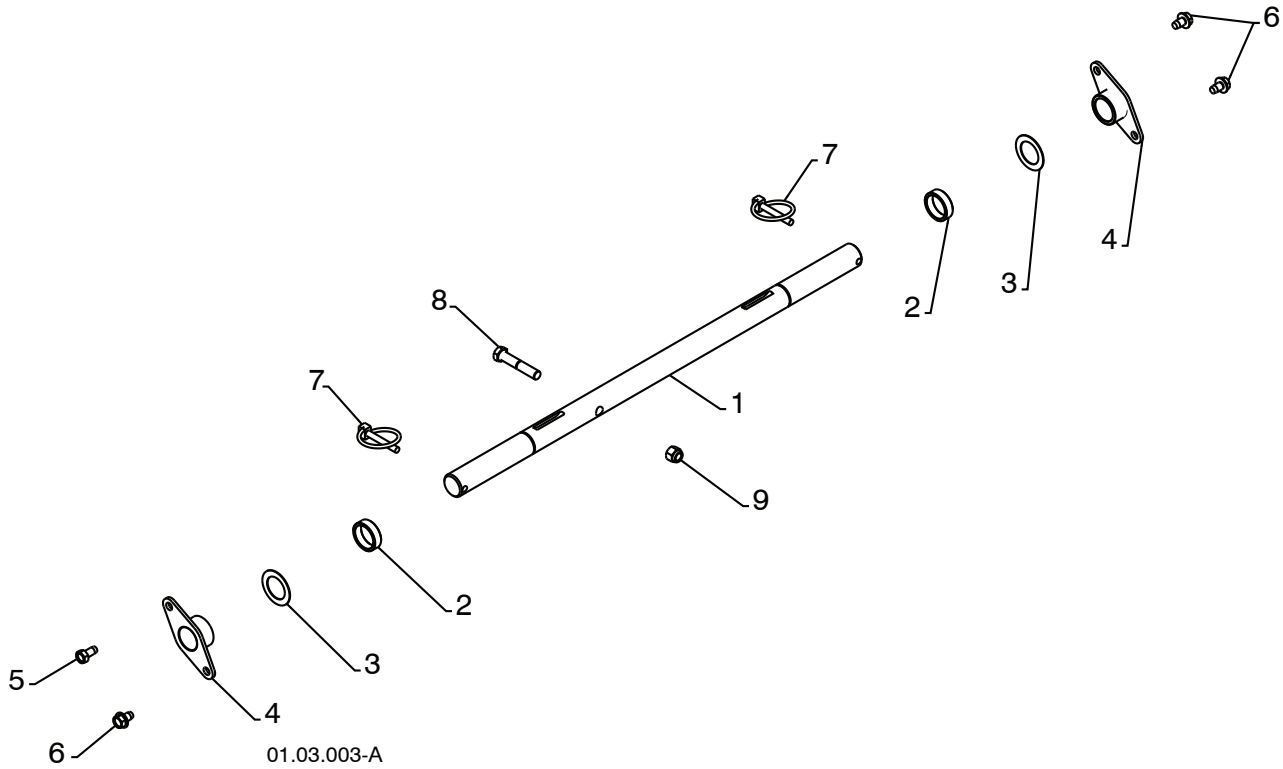

KEY NO.	PART NO.	DESCRIPTION
1	532 40 43-08	AXLE SHAFT
2	532 18 77-94	SPACER
3	532 17 46-97	THRUST WASHER
4	532 17 98-30	BEARING
5	532 14 63-15	SCREW 5/16-18 X .625
6	817 49 05-08	BOLT 5/16-18 X .500
7	532 15 54-43	CLIK PIN
8	874 78 06-32	SCREW 3/8-16 X 2.00
9	873 80 06-00	NUT 3/8-16

**NOTE:** All component dimensions given in U.S. inches. 1 inch = 25.4 mm  
**IMPORTANT:** Use only Original Equipment Manufacturer (O.E.M.) replacement parts.  
Failure to do so could be hazardous, damage your snow thrower and void your warranty.



# REPAIR PARTS

# CHASSIS / PULLEYS

SNOW THROWER - MODEL NO. 1827EXLT (96193007700), PRODUCT NO. 961 93 00-77

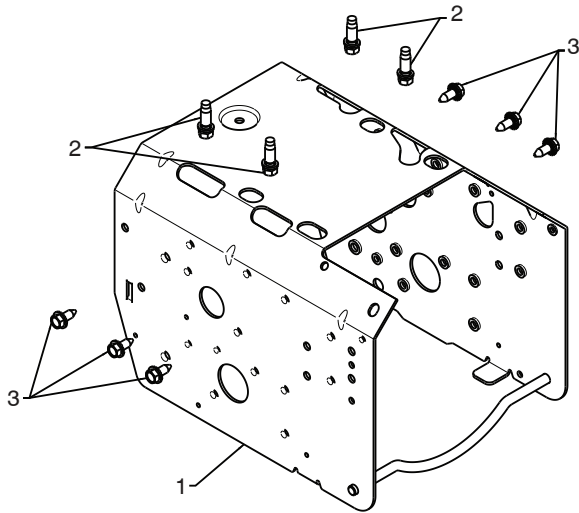

01.00.033-A

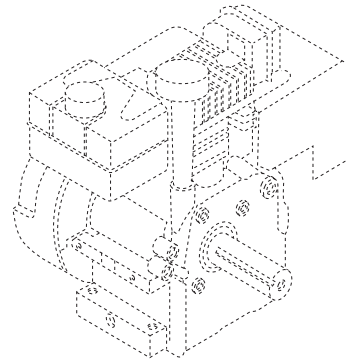

KEY NO.	PART NO.	DESCRIPTION
--	532 44 33-26	COMPLETE LCT ENGINE PW4HK191150781E
1	532 42 92-03	FRAME
2	532 15 04-06	BOLT 3/8-16
3	532 42 88-67	SCREW 5/16-18 X .750

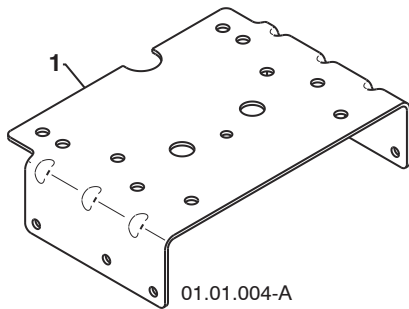

01.01.004-A

KEY NO.	PART NO.	DESCRIPTION
1	532 42 92-69	ENGINE MOUNTING PLATE

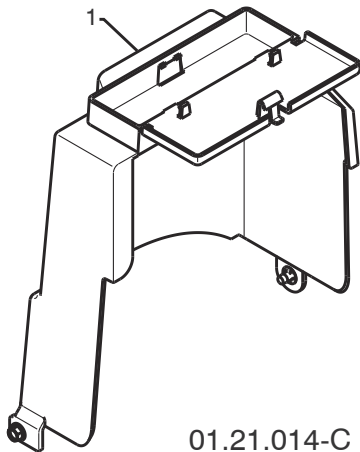

01.21.014-C

KEY NO.	PART NO.	DESCRIPTION
1	532 42 86-85	COVER ASSEMBLY

**NOTE:** All component dimensions given in U.S. inches. 1 inch = 25.4 mm  
**IMPORTANT:** Use only Original Equipment Manufacturer (O.E.M.) replacement parts. Failure to do so could be hazardous, damage your snow thrower and void your warranty.

# REPAIR PARTS

# CHASSIS / PULLEYS

SNOW THROWER - MODEL NO. 1827EXLT (96193007700), PRODUCT NO. 961 93 00-77

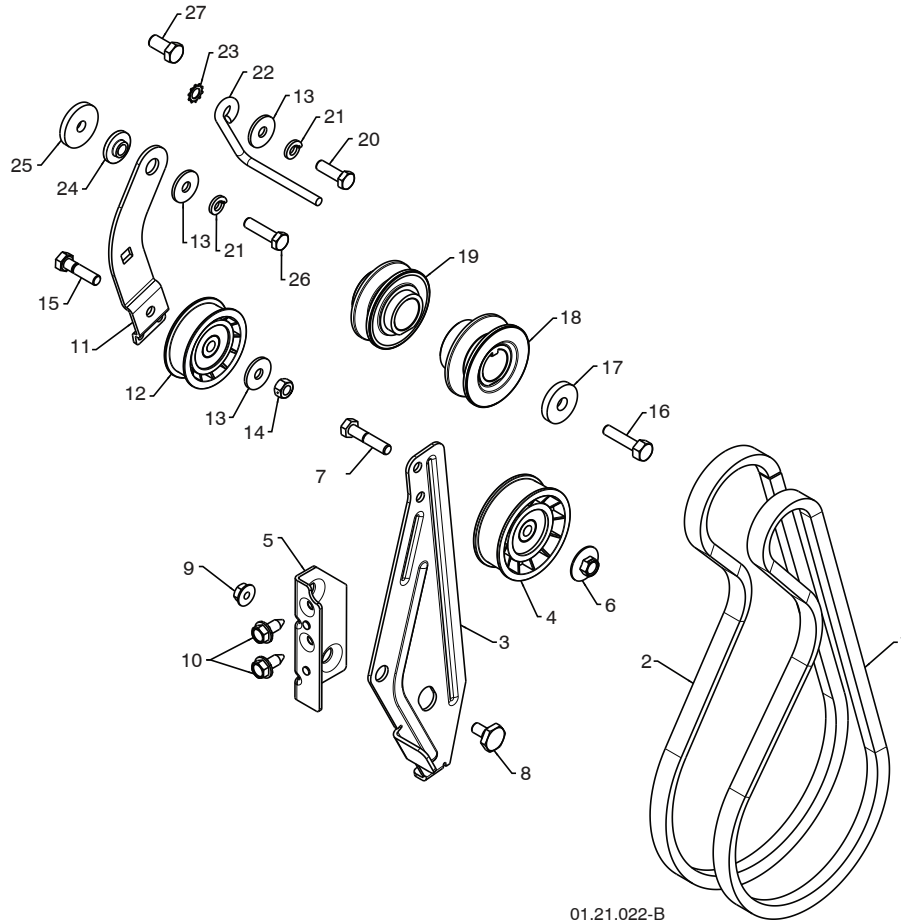

01.21.022-B

KEY NO.	PART NO.	DESCRIPTION	KEY NO.	PART NO.	DESCRIPTION
1	532 41 98-88	IMPELLER BELT	15	874 78 05-20	SCREW 5/16-18 X 1.25
2	532 42 84-54	TRACTION BELT	16	532 85 10-84	SCREW 3/8-24 X 1 .375
3	532 42 92-71	IDLER ARM BRACKET	17	819 13 20-05	WASHER
4	532 18 05-23	IDLER PULLEY	18	532 42 59-34	PULLEY ENG IMPELLER
5	532 42 92-70	IDLER BRACKET	19	532 42 59-33	PULLEY ENG TRACTION
6	532 42 65-89	NUT 5/16-18	20	874 61 05-16	SCREW 5/16-24 X 1.00
7	874 78 05-24	SCREW 5/16-18 X 1.50	21	810 04 05-00	LOCKWASHER 5/16
8	532 42 42-97	SHOULDER BOLT 5/16-18 X .50	22	532 19 36-07	BELT GUIDE
9	532 75 11-53	NUT 5/16-18 LOCK	23	811 05 05-00	LOCKWASHER 5/16
10	817 00 05-10	SCREW 5/16-18 X .625	24	532 17 53-31	IDLER BUSHING
11	532 42 75-76	TRACTION IDLER BRACKET	25	819 11 22-06	WASHER
12	532 18 05-22	TRACTION PULLEY	26	874 61 05-20	SCREW 5/16-24 X 1.25
13	532 05 92-89	WASHER	27	874 76 06-08	SCREW 3/8-16 X .750
14	873 80 05-00	NUT 5/16-18			

**NOTE:** All component dimensions given in U.S. inches. 1 inch = 25.4 mm  
**IMPORTANT:** Use only Original Equipment Manufacturer (O.E.M.) replacement parts.  
 Failure to do so could be hazardous, damage your snow thrower and void your warranty.

# REPAIR PARTS

# TRACKS

SNOW THROWER - MODEL NO. **1827EXLT** (96193007700), PRODUCT NO. 961 93 00-77

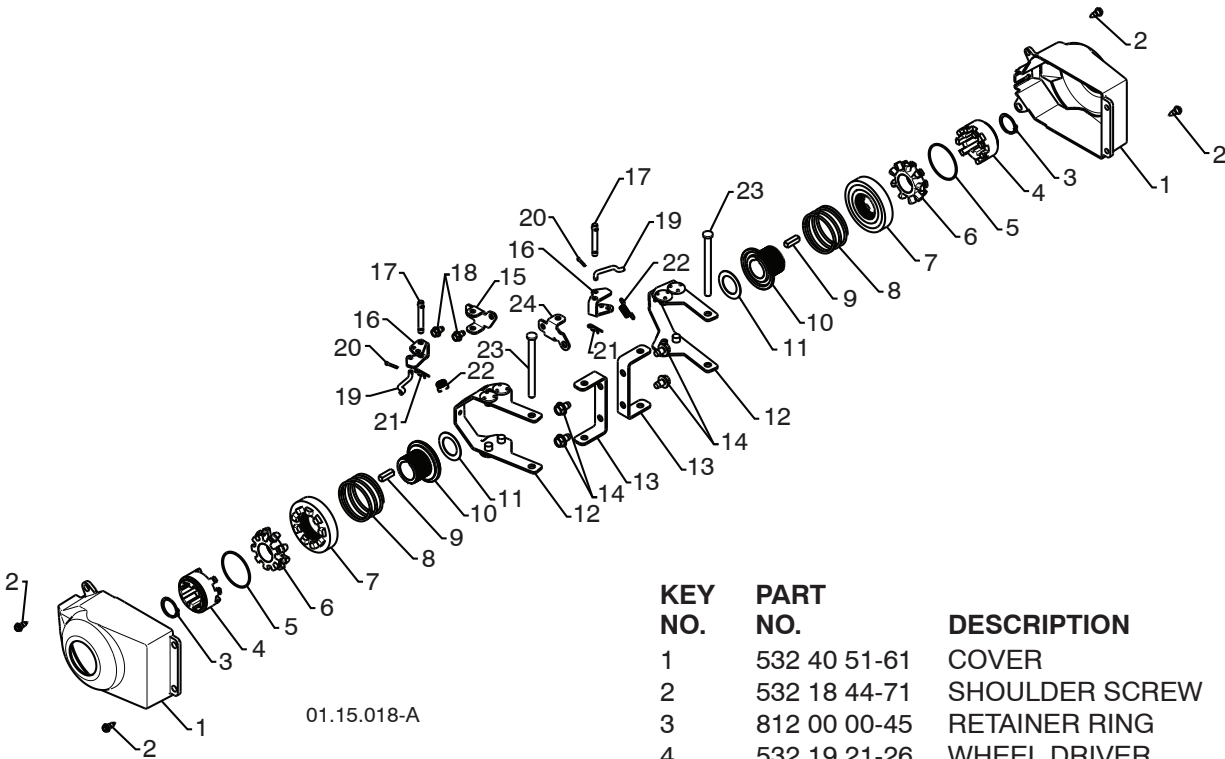

KEY NO.	PART NO.	DESCRIPTION
1	532 40 51-61	COVER
2	532 18 44-71	SHOULDER SCREW
3	812 00 00-45	RETAINER RING
4	532 19 21-26	WHEEL DRIVER
5	532 18 24-66	RETAINER RING
6	532 18 76-22	WHEEL LOBE
7	532 44 38-84	CLUTCH SLIDE
8	532 17 91-39	SPRING
9	532 18 92-82	SQUARE KEY
10	532 19 49-40	AXLE LOBE
11	532 17 46-97	THRUST WASHER
12	532 19 95-19	STEERING YOKE
13	532 18 41-97	STEERING BRACKET
14	817 49 05-08	SCREW 5/16-18 X .50
15	532 19 95-11	PIVOT BRACKET
16	532 19 95-18	BELLCRANK
17	532 18 18-47	BELLCRANK PIN
18	817 60 04-06	SCREW 1/4-20 X .375
19	532 40 50-77	STEERING LINK
20	532 70 02-79	RETAINER
21	532 08 51-79	RETAINER
22	532 19 38-85	SPRING
23	532 18 20-15	LEVER PIN
24	532 19 95-12	PIVOT BRACKET

**NOTE:** All component dimensions given in U.S. inches. 1 inch = 25.4 mm

**IMPORTANT:** Use only Original Equipment Manufacturer (O.E.M.) replacement parts. Failure to do so could be hazardous, damage your snow thrower and void your warranty.

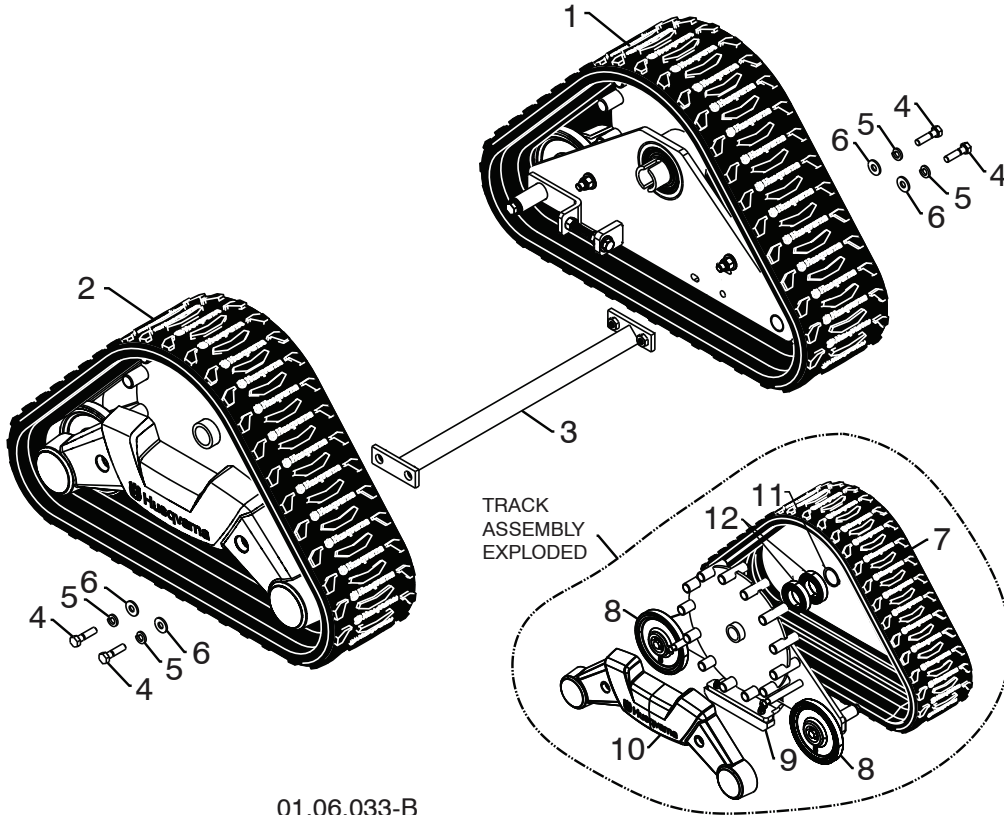

01.06.033-B

KEY NO.	PART NO.	DESCRIPTION	KEY NO.	PART NO.	DESCRIPTION
1	532 44 33-89	TRACK ASSEMBLY LH	7	532 44 33-90	TRACK BELT
2	532 44 33-88	TRACK ASSEMBLY RH	8	532 44 31-19	IDLER WHEEL
3	532 44 32-67	SUPPORT BRACE ASSEMBLY	9	532 44 33-91	NYLON SKID
4	874 78 05-20	CAPSCREW 5/16 – 18 X 1.25	10	532 44 27-45	COVER
5	810 04 05-00	LOCKWASHER 5/16	11	532 44 38-31	SNAP RING
6	532 15 54-15	FLAT WASHER	12	532 44 33-92	BALL BEARING

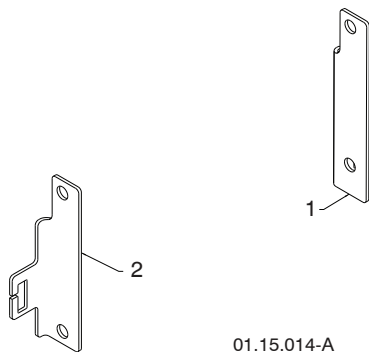

01.15.014-A

KEY NO.	PART NO.	DESCRIPTION
1	532 44 33-22	STEER CABLE BRACKET LH
2	532 43 84-45	STEER CABLE BRACKET RH

**NOTE:** All component dimensions given in U.S. inches. 1 inch = 25.4 mm  
**IMPORTANT:** Use only Original Equipment Manufacturer (O.E.M.) replacement parts. Failure to do so could be hazardous, damage your snow thrower and void your warranty.

# REPAIR PARTS

# BAG OF PARTS

SNOW THROWER - MODEL NO. 1827EXLT (96193007700), PRODUCT NO. 961 93 00-77

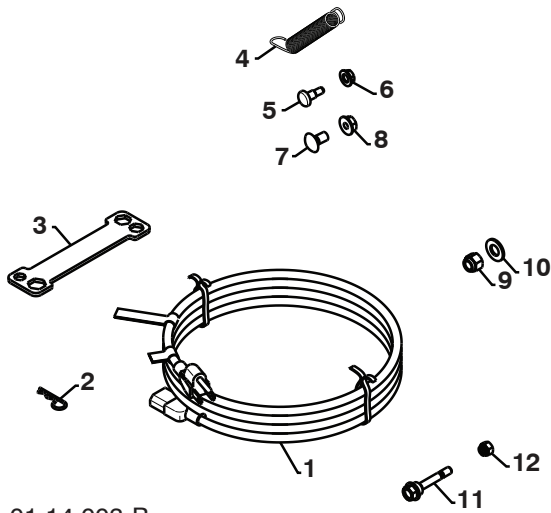

01.14.003-B

KEY NO.	PART NO.	DESCRIPTION
1	532 19 85-63	POWER CORD
2	532 16 96-75	RETAINER PIN
3	532 18 06-84	WRENCH
4	532 18 45-05	REMOTE SPRING
5	532 17 98-29	SHOULDER BOLT 1/4-20
6	532 19 17-30	LOCKNUT 1/4-20
7	872 25 05-05	CARRIAGE BOLT 5/16-18 X 5/8
8	532 75 11-53	LOCKNUT 5/16-18
9	873 80 06-00	LOCKNUT 3/8-16
10	819 13 13-16	WASHER 3/8
11	532 19 20-90	SHEAR BOLT 1/4-20 X 1-13/16
12	873 80 04-00	LOCKNUT 1/4-20

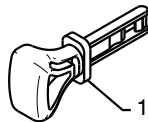

01.14.009-B

KEY NO.	PART NO.	DESCRIPTION
1	532 44 30-59	SAFETY IGNITION KEY KIT

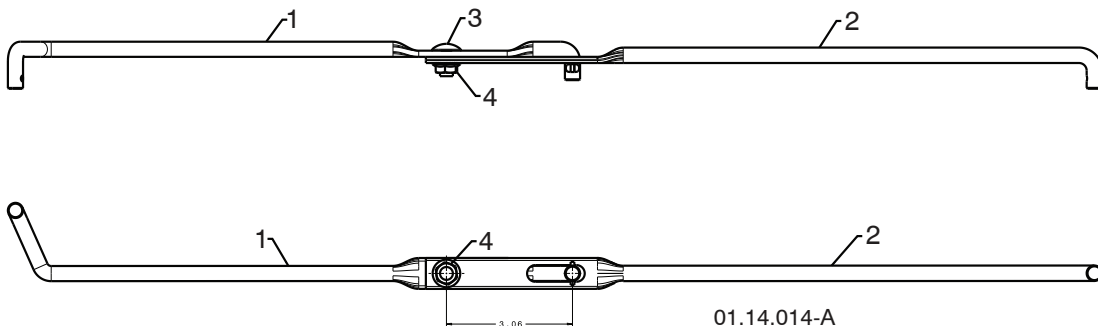

01.14.014-A

KEY NO.	PART NO.	DESCRIPTION
1	532 18 77-82	SHIFTER ROD TOP
2	532 18 77-84	SHIFTER ROD BOTTOM
3	872 27 05-05	CARRIAGE BOLT 5/16-18 X .75
4	532 15 53-77	NUT 5/16-18

**NOTE:** All component dimensions given in U.S. inches. 1 inch = 25.4 mm  
**IMPORTANT:** Use only Original Equipment Manufacturer (O.E.M.) replacement parts. Failure to do so could be hazardous, damage your snow thrower and void your warranty.

# REPAIR PARTS

# DECALS

SNOW THROWER - MODEL NO. 1827EXLT (96193007700), PRODUCT NO. 961 93 00-77

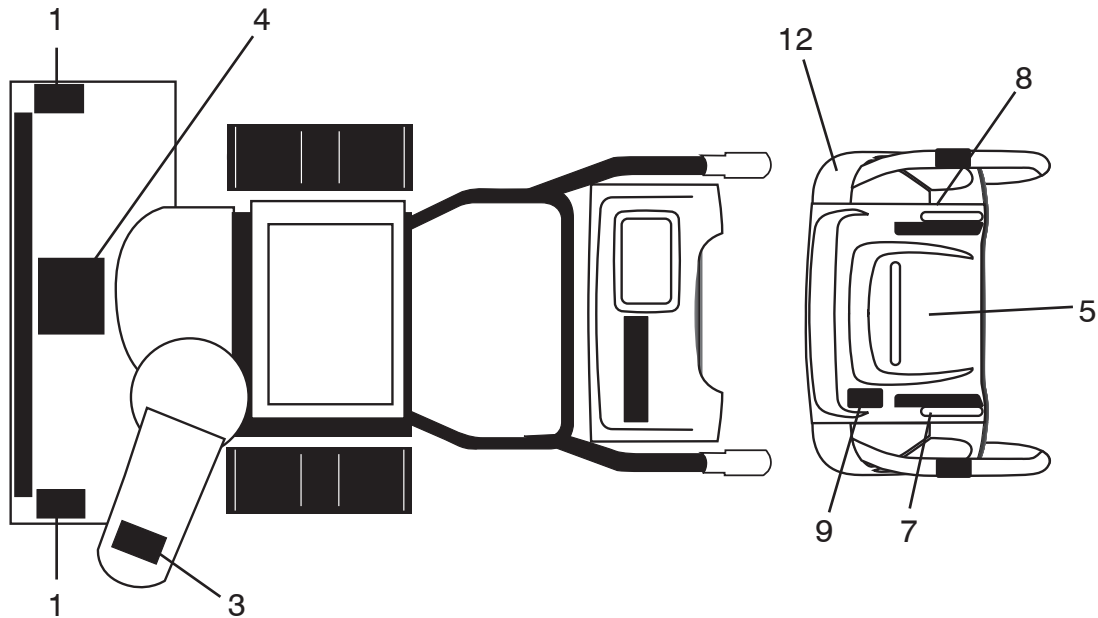

KEY NO.	PART NO.	DESCRIPTION
1	532 18 10-37	DECAL, DANGER
3	532 18 10-35	DECAL, DANGER, DEFLECTOR
4	532 18 10-42	DECAL, DANGER
5	532 42 95-73	DECAL, INSTRUTION
7	532 44 42-24	DECAL, LH TRIGGER
8	532 42 95-71	DECAL, RH TRIGGER
9	532 44 42-25	DECAL, HEIGHT ADJUST
12	532 44 47-68	DECAL, HANDWARMER
--	532 44 35-56	OPERATOR'S MANUAL, ENGLISH
--	532 44 35-57	OPERATOR'S MANUAL, FRENCH