

Replacement Parts

Replacement Parts are listed on the following pages. To order parts or reach our service department, call 1-800-274-6848, Monday through Friday (see our website for business hours, www.waltermeier.com). Having the Model Number and Serial Number of your machine available when you call will allow us to serve you quickly and accurately.

Breakdown for PM1900TX Dust Collector (Base Machine)

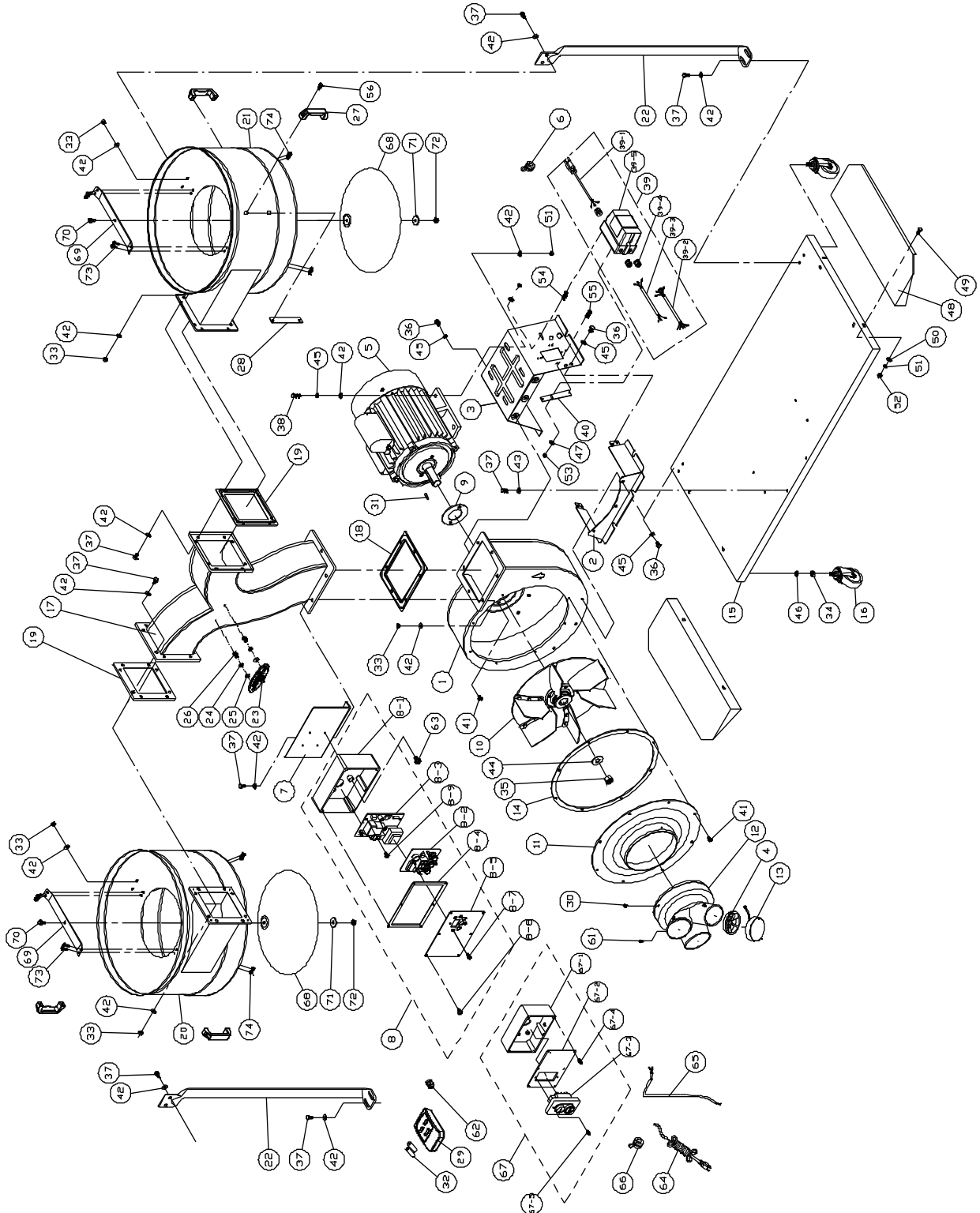

Parts List for PM1900TX Dust Collector (Base Machine)

Index No.	Part No.	Description	Size	Qty
1	PM1900-101	Impeller Housing		1
2	PM1900-102	Impeller Housing Bracket		1
3	PM1900-103-1	Motor Bracket	1Ph	1
	PM1900-103-3	Motor Bracket	3Ph	1
4	PM1300-151	Inlet Guard		3
5	PM1900-105-1	Motor	3HP, 230V, 1Ph	1
	PM1900-105-1MF	Motor Fan (not shown)		1
	PM1900-105-1MFC	Motor Fan Cover (not shown)		1
	PM1900-105-1SC	Starting Capacitor (not shown)	600MFD, 125VAC	1
	PM1900-105-1RC	Running Capacitor (not shown)	50µF, 250VAC	2
	PM1900-105-1CS	Centrifugal Switch (not shown)		1
	PM1900-105-3	Motor	3HP, 230/460V, 3Ph	1
	PM1900-105-1MF	Motor Fan (not shown)		1
	PM1900-105-1MFC	Motor Fan Cover (not shown)		1
6	998630	Strain Relief	7P-2	2
7	PM1900-107	Mount Plate		1
8	PM1900-108	Remote Control Switch Assembly	For 3HP, 230V, 1Ph	1
8-1	DCRC-108	Switch Box		1
8-2	PM1900-108-2	Circuit Board		1
8-3	PM1900-108-3	Digital Switch		1
8-4	DCRC-104	Seal		1
8-5	DCRC-103	Switch Plate		1
8-6	PM1900-108-6	Pan Head Screw	M5x8	4
8-7	DCRC-102	Flat Head Screw	1/8" x 1/4"	3
8-8	ST039304	Tapping Screw	M3.5x12(AB)	6
8-9	DCRC-111	Tapping Screw	M4x10	1
	PM1900-108-10	Display Label (not shown)		1
9	420051	Motor Gasket		1
10	431006	Impeller	Dia. 14"	1
11	PM1900-111	Inlet Guard	8"	1
12	499025	Inlet Port	3 @ 4"	1
13	420203	Inlet Cap		2
14	431034	Rubber Gasket		1
15	PM1900-115	Base		1
16	402036	Caster		4
17	PM1900-117	Connector Tube		1
18	430035	Rubber Gasket		1
19	430036	Rubber Gasket		2
20	PM1900-120	Left Housing		1
21	PM1900-121	Right Housing		1
22	PM1900-122	Support Bar		2
23	PWBS14-254SN	POWERMATIC Nameplate, Small		1
24	TS-2361061	Lock Washer	M6	2
25	TS-1550041	Flat Washer	M6	2
26	6715154	Hex Cap Screw	1/4-20 x 3/8	2
27	PM1900-127	Handle		4
28	PM1900-128	Fastening Plate		4
29	PM1900-129	Remote Control		1
	PM1900-129-1	Remote Control Label (not shown)		1
30	990855	Pan Head Flange Screw	3/16 x 1/2	1
31	992021	Key	7x7x20	1
32		Battery (local purchase)	AAA	2
33	TS-1540061	Hex Nut	M8	30
34	TS-0561031	Hex Nut	3/8-16	4
35	TS-0561072	Hex Nut	5/8-18 UNF	1
36	TS-1490011	Hex Cap Screw	M8x12	10
37	TS-1490031	Hex Cap Screw	M8x20	36

Index No.	Part No.	Description	Size	Qty
38	TS-1490041	Hex Cap Screw	M8x25	4
39	PM1900-139	Magnetic Switch	for 3HP, 230V, 1Ph	1
39-1	PM1900-139-1	Power Cord	14AWG x 3C	1
39-2	PM1900-139-2	Motor Cord	14AWG x 3C	1
39-3	PM1900-139-3	Switch Cord	14AWG x 3C	1
40	PM1900-140	Fastening Plate		1
41	SF069300	Pan Head Flange Screw	M6x12	10
42	TS-1550061	Flat Washer	M8	64
43	TS-1550071	Flat Washer	M10	6
44	TS-155010	Flat Washer	M16	1
45	TS-2361081	Lock Washer	M8	14
46	TS-2361101	Lock Washer	M10	4
47	TS-1550031	Flat Washer	M5	2
48	PM1900-148	Base Extension		2
49	TS-1490031	Hex Cap Screw	M8x20	4
50	TS-1550061	Flat Washer	M8	4
51	TS-2361081	Lock Washer	M8	4
52	TS-1540061	Hex Nut	M8	4
53	TS-1540031	Hex Nut	M5	2
54	TS-1533042	Pan Head Screw	M5x12	2
55	PM1900-108-6	Tapping Screw	M5x8	2
56	TS-1504021	Socket Head Cap Screw	M8x12	8
57	DCRC-111	Tapping Screw	M3.5x10(AB)	6
58	31A-208-2	Strain Relief	PG13.5	1
59	PM1900-157	Power Cord	14AWG x 4C (for 3HP, 3Ph)	1
60	PM1900-158	Motor Cord	14AWG x 4C (for 3HP, 3Ph)	1
61	998630	Strain Relief		1
62	PM1900-160	Switch Assembly	For 3HP, 230/460V, 3Ph	1
62-1	PM1900-160-1	Switch Box		1
62-2	PM1900-160-2	Switch Plate		1
62-3	PM1900-160-3	Push Button Switch		1
62-4	ST039304	Tapping Screw	M3.5x12	6
62-5	PM1900-160-5	Tapping Screw	M5x12	2
	PM1900-BMHP	Base Machine Hardware Package (not shown)*		1
	PM1900-BEHP	Base Extension Hardware Package (not shown)**		1
68	PM1300-155	Cone		2
69	DC1100-47-1	Support Bracket		2
70	TS-1490021	Hex Cap Screw	M8x16	2
71	TS-1550061	Flat Washer	M8	2
72	TS-1540061	Hex Nut	M8	2
73	TS-1482021	Hex Head Bolt	M6x12	8
74	TS-2311061	Hex Nut	M6	8
	PM1900-BMHP	Base Machine Hardware Package (not shown)*		1
	PM1900-BEHP	Base Extension Hardware Package (not shown)**		1
	DC1100-HP2	Hardware Package for Cone Assembly (index # 70 thru 74)		2

* Base Machine Hardware Package includes index # 30, 33, 37, 41, 42 and 43.

** Base Extension Hardware Package includes index # 49 thru 52.

Parts List and Breakdown for PM1900TX Filter Bag System

Index No.	Part No.	Description	Size	Qty
.....	1791075B.....	Collection and Filter Bag System (includes #1 thru 6).....		1
1.....	1791075F.....	Filter Bag.....	30 micron.....	2
2.....	430005.....	Retainer Strap.....		2
3.....	708699A.....	Collection Bag.....		2
4.....	430039.....	Upper Hanger.....		2
5.....	430037.....	Support Bar.....		2
6.....	523011.....	Hanger Bracket.....		2

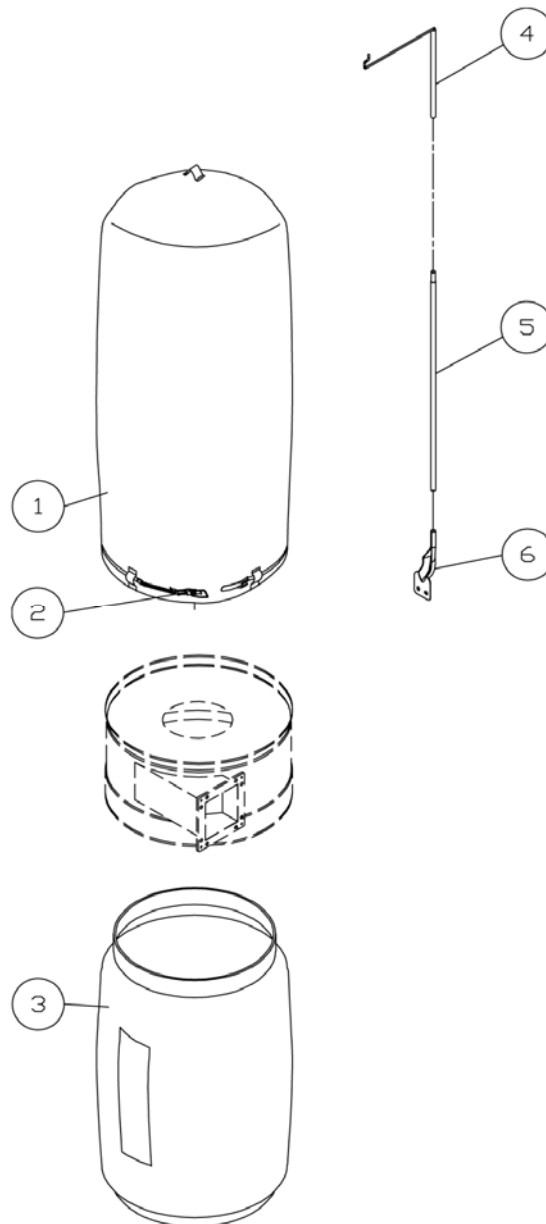

Breakdown for PM1900TX Canister Filter System

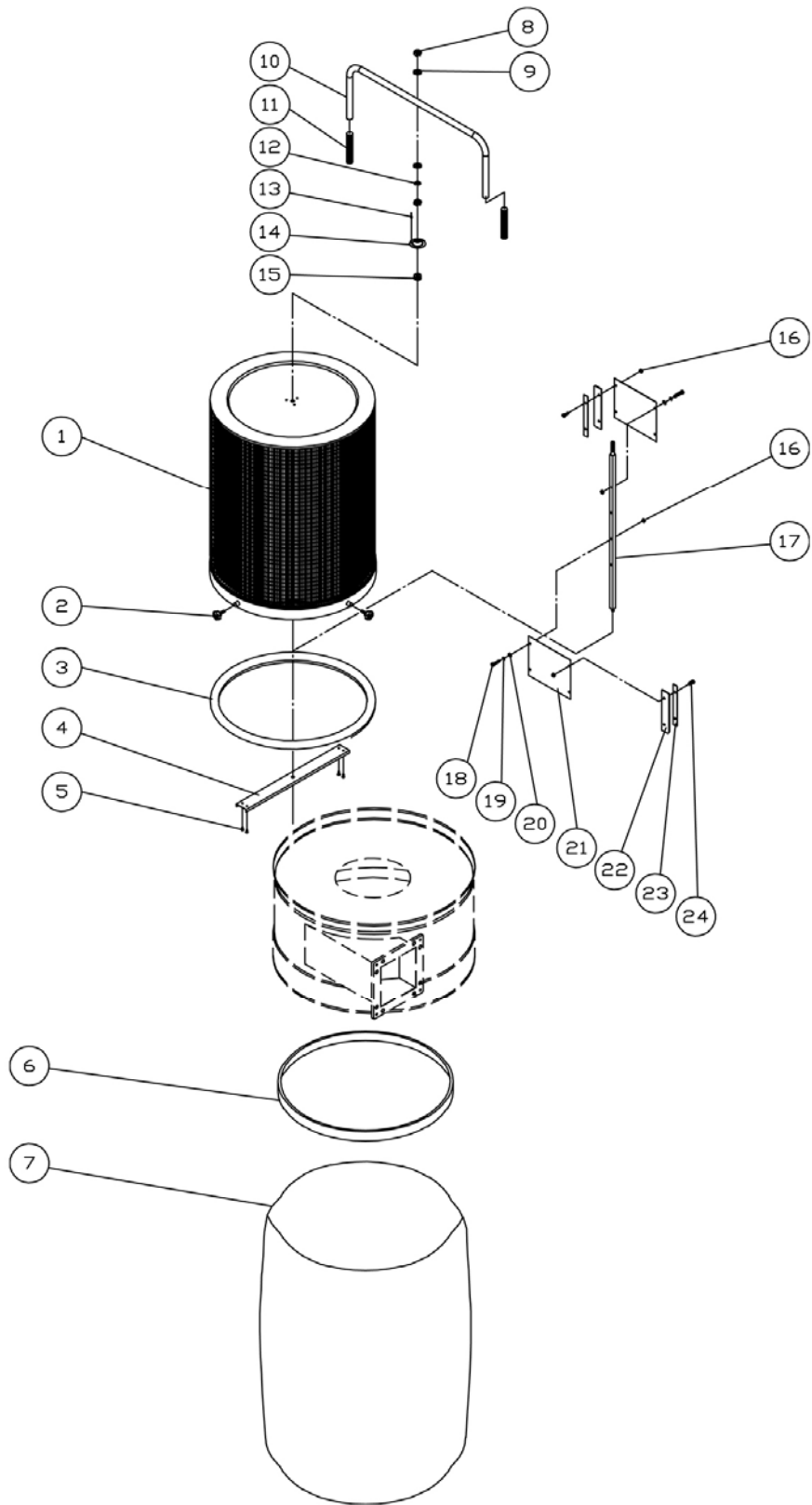

Parts List for PM1900TX Canister Filter System

Index No.	Part No.	Description	Size	Qty
	1791086	Canister Filter System (includes #1 thru 24)		2
1	PM1900-301	Canister Filter		1
2	PM1900-302	Knob	M6x20	4
3	331031	Pad		1
4	331009	Support		1
5	ST049200	Tapping Screw	M4x8	4
6	331038	Snap Ring		1
7	1791087	Plastic Collection Bag (Package of 5)	800x1050x0.1t mm	1
8	TS-1540071	Hex Nut	M10	2
9	TS-1550071	Flat Washer	M10	2
10	331050	Handle		1
11	331051	Soft Grip Handle		2
12	TS-2361101	Lock Washer	M10	1
13	BR000052	Rivet	5-2	3
14	331014	Bracket		1
15	150623	Rubber Mount		1
16	TS-1540041	Hex Nut	M6	8
17	331052	Shaft		1
18	TS-1482041	Hex Cap Screw	M6x20	4
19	TS-2361061	Lock Washer	M6	4
20	TS-1550041	Flat Washer	M6	4
21	331012	Scraper		2
22	331017	Plate		2
23	331015	Plate		2
24	TS-1482021	Hex Cap Screw	M6x12	4
	PM1300-PLO	Powermatic Label (not shown)	5-1/2x14 Oval	1
	PM1900-CHP	Canister Hardware Package (not shown) *		1

* Canister Hardware Package includes index # 2, 8, 9 and 12.

Electrical Connections

Installation work and electrical wiring must be done by qualified person(s) in accordance with all applicable codes and standards, including fire-rated construction.

