

POWERMATIC®

Operating Instructions and Parts Manual 18-, 20-, 24-inch Band Saws Models PM1800B, PM2013B, PM2415B



PM2013B shown

Powermatic
427 New Sanford Road
LaVergne, Tennessee 37086
Ph.: 800-274-6848
www.powermatic.com

Part No. M-1791800B
Revision B1 09/2018
Copyright © 2018 Powermatic

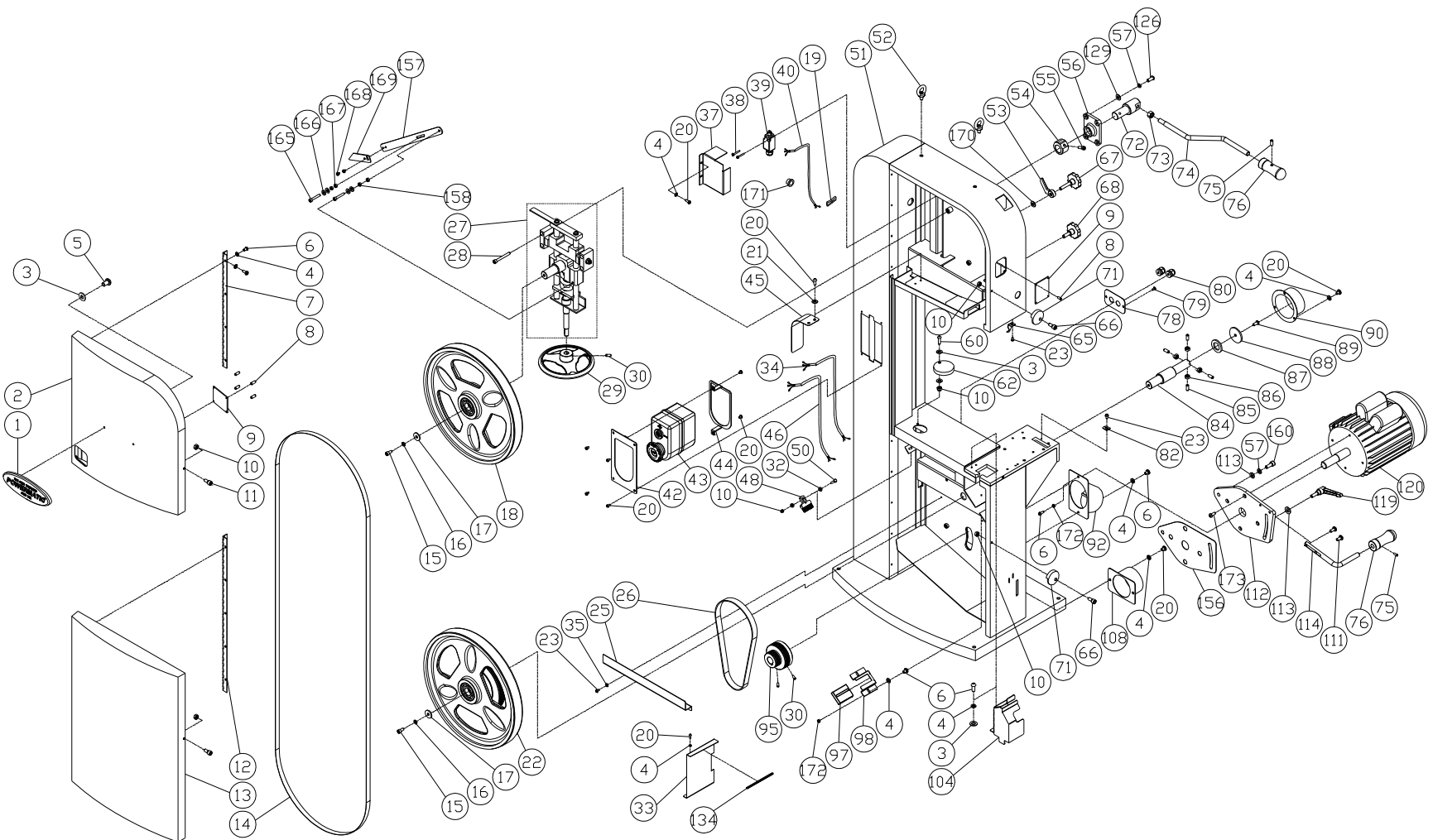

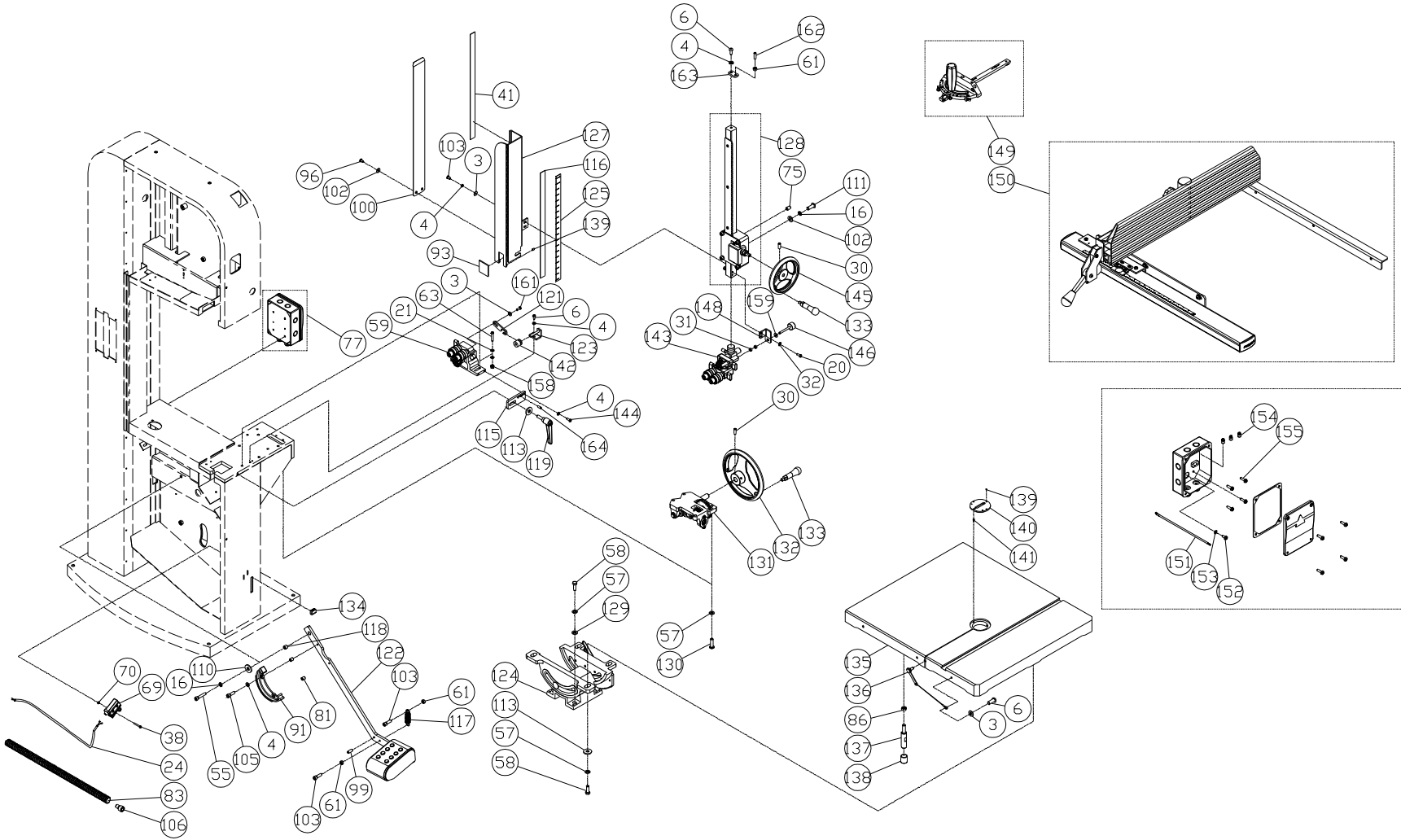

17.1.5 Complete Machine with Accessories – PM1800B, PM2013B and PM2415B – Parts List

Index No	Part No	Description	Size	Qty
1	PM2000-105	Powermatic Nameplate, Large		1
2	PM1800B-002	Upper Cabinet Door		1
	PM2013B-002	Upper Cabinet Door		1
	PM2415B-002	Upper Cabinet Door		1
3	TS-1550041	Flat Washer	M6 x ø16	10
4	TS-2361061	Spring Washer (for 1800B & 2013B)	M6	42
	TS-2361061	Spring Washer (for 2415B)	M6	44
5	TS-081F021	Phillips Pan Head Machine Screw	1/4"-20UNC x 3/8"L	2
6	TS-2246202	Hex Socket Button Hd Screw (for 1800B & 2013B)	M6x12	28
	TS-2246202	Hex Socket Button Hd Screw (for 2415B)	M6x12	30
7	PM1800B-007	Upper Door Hinge		1
	PM2013B-007	Upper Door Hinge		1
	PM2415B-007	Upper Door Hinge		1
8	TS-1521031	Set Screw	M4 x 8	8
9	PM1500-050	Viewing Window		2
10	TS-1541021	Nylon Lock Hex Nut	M6	6
11	TS-1503021	Hex Socket Hd Cap Screw	M6 x 10	2
12	PM1800B-012	Lower Door Hinge		1
	PM2013B-012	Lower Door Hinge		1
	PM2415B-012	Lower Door Hinge		1
13	PM1800B-013	Lower Cabinet Door		1
	PM2013B-013	Lower Cabinet Door		1
	PM2415B-013	Lower Cabinet Door		1
14	PM1800B-014	Saw Blade, Hook type	160"L / 3/4" / 0.65mm THK	1
	PM2013B-014	Saw Blade, Hook type	170"L / 1" / 0.9mm THK	1
	PM2415B-014	Saw Blade, Hook type	183"L / 1" / 0.9mm THK	1
15	TS-1490031	Hex Cap Screw	M8 x 20	2
16	TS-2361081	Lock Washer	M8	7
17	PM1800B-017	Special Flat Washer		2
18	PM1800B-018	Upper Wheel Assembly		1
	PM2013B-018	Upper Wheel Assembly		1
	PM2415B-018	Upper Wheel Assembly		1
19	PM1500-040	Wire Connector	224-201	1
20	TS-2246082	Hex Socket Button Hd Screw (for 1800B & 2013B)	M6 x 8	19
	TS-2246082	Hex Socket Button Hd Screw (for 2415B)	M6 x 8	17
21	TS-1550041	Flat Washer (for 1800B & 2013B)	M6 x ø16	4
	TS-1550041	Flat Washer (for 2415B)	M6 x ø16	2
22	PM1800B-022	Lower Wheel Assembly		1
	PM2013B-022	Lower Wheel Assembly		1
	PM2415B-022	Lower Wheel Assembly		1
23	PM1800B-023	Hex Socket Button Head Screw	M5 x 8	4
24	PM1800B-024	Limit Switch Cord	18AWG x 2C x 2.8M	1
25	PM1800B-025	Brake Cable Bracket	L:456mm	1
	PM2013B-025	Brake Cable Bracket	L:507mm	1
	PM2415B-025	Brake Cable Bracket	L:613mm	1
26	PM1800B-026	Belt	PK x 7 ribs x 37"	1
	PM2013B-026	Belt	PK x 7 ribs x 35"	1
	PM2415B-026	Belt	PK x 7 ribs x 32"	1
27	PM1800B-027	Upper Wheel Sliding Bracket Assembly		1
	PM2013B-027	Upper Wheel Sliding Bracket Assembly		1
	PM2415B-027	Upper Wheel Sliding Bracket Assembly		1
28	PM1800B-028	Hex Head Bolt	M10 x 55	4
29	PM1800B-029	Hand wheel		1
30	TS-1523041	Set Screw	M6 x 12	8
31	PM1800B-031	Hex Nut	M8 x 1.25 (LH)	2
32	TS-1550041	Flat washer	M6 x ø13	4
33	PM1800B-033	Protective Cover (for 1800B)		1
	PM2013B-033	Protective Cover (for 2013B & 2415B)		1

Index No	Part No	Description	Size	Qty
34	PM1800B-034-1	Motor Cord	12AWG x 3C, 300V, SJT, 105°C, CSA/UL	1
	PM1800B-034-3	Motor Cord	14AWG x 4C, 600V, ST, 105°C, CSA/UL	1
35	TS-2361051	Lock Washer	M5	2
37	PM1800B-037	Limit Switch Guard		1
	PM2013B-037	Limit Switch Guard		1
	PM2415B-037	Limit Switch Guard		1
38	TS-2284302	Phillips Pan Head Machine Screw	M4 x 30	4
39	PM1500-051	Limit Switch	AZD-1112(UL)	1
40	PM1800B-040	Switch Cord	18AWG x 2C x 1.1M	1
41	PM1800B-041	Magnet Strip		1
42	PM1500-043	Switch Plate		1
43	PM1800B-043A	Magnetic Switch(C-18D/NTH-25)	5HP/230V/60Hz/1PH	1
	PM1800B-043B	Magnetic Switch(C-12D10/NTH-17)	5HP/230V/60Hz/3PH	1
	PM1800B-043C	Magnetic Switch(C-09D10/NTH-8)	5HP/460V/60Hz/3PH	1
	PM2000-298	Safety Key		1
44	PM1500-006	Switch Bracket		1
45	PM1800B-045	Guide Plate (for 1800B & 2013B)		1
46	PM1800B-045-1	Power Cord	12AWG x 3C, 300V, SJT, 105°C, CSA/UL	1
	PM1800B-045-3	Power Cord	14AWG x 4C, 600V, ST, 105°C, CSA/UL	1
48	PM1500-058	Brush		1
50	TS-1482051	Hex Cap Screw	M6 x 25	1
51	PM1800B-051	Machine Main Body Frame		1
	PM2013B-051	Machine Main Body Frame		1
	PM2415B-051	Machine Main Body Frame		1
52	DT45-309	Lifting Eye Bolt	M10	2
53	PM1800B-053	Lock Handle	M10	1
54	PM1800B-054	Cam		1
55	TS-1490041	Hex Cap Screw	M8 x 25	2
56	PM1800B-056	Shaft Fixed Block		1
57	TS-2361101	Lock Washer	M10	17
58	TS-1491041	Hex Cap Screw	M10 x 30	8
59	PM1800B-059	Lower Blade Guide Support Assembly		1
60	TS-2246302	Hex Socket Button Head Screw	M6 x 30	1
61	TS-1540041	Hex Nut (for 1800B & 2013B)	M6	3
	TS-1540041	Hex Nut (for 2415B)	M6	2
62	PM1800B-062	Bracket		1
63	PM1800B-063	Hex Socket Button Head Screw	M5 x 35	1
65	PM1500-063	Pointer		1
66	TS-1503061	Hex Socket Hd Cap Screw	M6 x 25	2
67	PM1500-067	Lock Knob	M10 x 50	1
68	PM1500-055	Lock Knob	M10 x 30	1
69	PM1800B-069	Limit Switch	MN-5141	1
70	TS-1540021	Hex Nut	M4	2
71	PM1500-060	Door Lock Knob		2
72	PM1800B-072	Tension Quick Release Lever Shaft		1
73	TS-154009	Hex Nut	M14	1
74	PM1800B-074	Tension Quick Release Lever	L:371mm	1
	PM2013B-074	Tension Quick Release Lever	L:397mm	1
	PM2415B-074	Tension Quick Release Lever	L:450mm	1
75	TS-1524011	Set Screw	M8 x 8	6
76	PM1800B-076	Tension Quick Release Handle		2
77	PM1800B-077	Wire Connection Box		1
78	PM1500-083	Strain Relief Fixed Plate		1
79	PM1500-039	Tapping Screw	M4 x 8	2
80	PM1800B-080	Strain Relief	M20	2
81	PM1500-127	Bushing		2
82	PM1800B-082	Pointer		1
83	PM1800B-083	Protective Tube	ø12 x 1100mm	1
84	PM1800B-084	Lower Wheel Shaft		1
85	TS-2279301	Set Screw	M10 x 30	4
86	TS-2311101	Hex Nut	M10	5

Index No	Part No	Description	Size	Qty
87	PM1800B-087	Special Washer		1
88	PM1800B-088	Special Washer		1
89	TS-1504051	Socket Head Cap Screw	M8 x 25	1
90	PM1800B-090	Cover		1
91	PM1500-128	Brake Pad		1
92	PM1800B-092	Dust Chute		1
93	PM1800B-093	Viewing Window		1
95	PM1800B-095	Motor Pulley	ø100mm/60mm	1
	PM2013B-095	Motor Pulley	ø91mm/55mm	1
	PM2415B-095	Motor Pulley	ø82mm/55mm	1
96	TS-2248122	Hex Socket Button Head Screw	M8 x 12	2
97	JWBS18DX-249	Insert Block		1
98	PM1800-243	Shelf		1
99	PM1500-124	Nylon Set Screw	M7 x 10	1
100	PM1800B-100	Sliding Plate		1
102	TS-1550061	Flat Washer	M8 x ø18	6
103	TS-1482031	Hex Cap Screw	M6 x 16	4
104	PM1800B-104	Lower Blade Guard		1
105	TS-1482051	Hex Cap Screw	M6 x 25	2
106	PM1800B-106	Wire Bushing		1
108	PM1800B-108	Dust Chute		1
110	TS-1550061	Flat Washer	M8 x ø30	1
111	TS-2248202	Hex Socket Button Head Screw	M8 x 20	6
112	PM1800B-112	Motor Mount Plate		1
113	TS-1550071	Flat Washer	M10 x ø27 x 3	7
114	PM1800B-114	Lift Lever		1
115	PM1800B-115	Bracket		1
116	PM1800B-116	Sponge		1
117	PM1500-122	Spring		1
118	PM1500-133	Bushing		1
119	PM1800B-119	Tension Quick Release Handle		2
120	PM1800B-120A	Motor	230V,5HP,1Ph	1
	PM1800B-120MF	Motor Fan (not shown)		1
	PM1800B-120MFC	Motor Fan Cover (not shown)		1
	PM1800B-120SC	Starting Capacitor (not shown)	300MFD, 250VAC	1
	PM1800B-120RC	Running Capacitor (not shown)	45µf, 450VAC	1
	PM1800B-120CC	Capacitor Cover (not shown)		1
	PM1800B-120JB	Junction Box (not shown)		1
	PM1800B-120JBC	Junction Box Cover (not shown)		1
	PM1800B-120CS	Centrifugal Switch (not shown)		1
	PM1800B-120B	Motor	230/460V,5HP,3Ph	1
121	PM1800B-121	Connection Plate		1
122	PM1800B-122	Brake Linkage Assembly		1
	PM2013B-122	Brake Linkage Assembly		1
	PM2415B-122	Brake Linkage Assembly		1
123	PM1800B-123	Fixed Bracket		1
124	PM1800B-124	Trunnion Support Bracket Assembly		1
125	PM1800B-125	Guide Post Scale (for 1800B & 2013B)		1
	PM2415B-125	Guide Post Scale		1
126	TS-2249252	Hex Socket Button Head Screw	M10 x 25	4
127	PM1800B-127	Blade Guard Cover		1
128	PM1800B-128	Guide Bar Bracket Assembly		1
129	TS-1550071	Flat Washer	M10 x ø20 x 2	8
130	TS-2248302	Hex Socket Button Head Screw	M8 x 30	4
131	PM1800B-131	Gear Bracket Assembly		1
132	PM1800B-132	Handwheel		1
133	3520B-126	Handle		2
134	PM1800B-134	Rubber Set	9 x 160	1
135	PM1800B-135	Table (for 1800B & 2013B)	24" x 27"	1
	PM2415B-135	Table	24" x 34"	1
136	PM1800B-136	Table Pin Assembly		1

Index No	Part No	Description	Size	Qty
137	PM1800B-137	Stop Bolt		1
138	PM1800B-138	Sheath		1
139	PM1800B-139	Set Screw	M4 x 5	5
140	PM1800B-140	Table Insert		1
141	PM1800B-141	Pin	ø4 x 10	2
142	PM1800B-142	Adjusting Knob		1
143	PM1800B-143	Upper Blade Guide Support Assembly		1
144	TS-2246202	Hex Socket Button Head Screw	M6 x 20	2
145	PM1500-090	Handwheel		1
146	PM1800B-146	Adjusting Knob		1
148	PM1800B-148	Fixed Bracket		1
149	PM1800B-149	Miter Gauge Assembly		1
150	PM1800B-150	Fence Assembly		1
	PM2013B-150	Fence Assembly		1
	PM2415B-150	Fence Assembly		1
151	PM1800B-151	Ground Wire		1
152	TS-1533032	Phillips Pan Head Machine Screw	M5 x 10	2
153	JWS25X-405	Star Washer	M5	2
154	PM1800B-154	Wire Cap	P4	3
155	PM1800B-155	Phillips Pan Head Machine Screw (Big)	M5 x 10	4
156	PM1800B-156	Motor Protective Plate		1
157	PM1800B-157	Tension Pointer		1
158	TS-1541011	Nylon Lock Hex Nut	M5	3
159	PM1800B-159	Special Washer	ø16 x ø8.2 x 0.4t	1
160	TS-1505051	Socket Head Cap Screw	M10 x 35	1
161	TS-1482021	Hex Cap Screw	M6 x 12	1
162	TS-1523081	Set Screw (for 1800B & 2013B)	M6 x 30	1
	PM2415B-162	Adjust Block (for 2415B)		1
163	PM1800B-163	Plate (for 1800B & 2013B)		1
164	TS-1523021	Set Screw	M6 x 8	2
165	PM1800B-165	Hex Socket Button Head Screw	M5 x 35	2
166	PM1800B-166	Plastic Flat Washer	ø6 x ø13 x 1.5t	4
167	TS-1540031	Hex Nut	M5	2
168	PM1800B-168	Phillips Pan Head Machine Screw (Big)	M4 x 5	2
169	PM1800B-169	Tension Scale Indicator	L:75mm	1
	PM2013B-169	Tension Scale Indicator	L:115mm	1
	PM2415B-169	Tension Scale Indicator	L:175mm	1
170	PM1800B-170	Copper Washer	ø10 x ø20 x 0.5t	1
171	PM1800B-171	Bushing	Type 0813C	1
172	PM1800B-172	Hex Flange Nut	M6	2
173	TS-2288202	Phillips Flat Head Machine Screw	M8 x 20	4
	3520B-157	Upper (Narrow) Stripe, 50"L (not shown)		3
	3520B-158	Lower (Wide) Stripe, 50"L (not shown)		1
	PM1500-WL	Warning Label (not shown)	4"H x 5-1/4"W	1
	PM1800B-ID-1	I.D. Label (not shown)	1791800B	1
	PM1800B-ID-3	I.D. Label (not shown)	1791801B	1
	PM2013B-ID-1	I.D. Label (not shown)	1791257B	1
	PM2013B-ID-3	I.D. Label (not shown)	1791258B	1
	PM2014B-ID-1	I.D. Label (not shown)	1791259B	1
	PM2014B-ID-3	I.D. Label (not shown)	1791260B	1
	PM1800B-TLL	Tension Lever Label (not shown)		1
	PM1800B-BTL	Blade Tension Label (not shown)		1
	PM2013B-BTL	Blade Tension Label (not shown)		1
	PM2415B-BTL	Blade Tension Label (not shown)		1
	PM1800B-ML-1	Motor Label (not shown)	1791800B	1
	PM1800B-ML-3	Motor Label (not shown)	1791801B	1
	PM2013B-ML-1	Motor Label (not shown)	1791257B	1
	PM2013B-ML-3	Motor Label (not shown)	1791258B	1
	PM2014B-ML-1	Motor Label (not shown)	1791259B	1
	PM2014B-ML-3	Motor Label (not shown)	1791260B	1

17.2.1 Upper Wheel Assembly – Exploded View

Part Assembly No.: PM1800B-018 (#1-6) / PM2013B-018 (#1-5) / PM2415B-018 (#1-5)

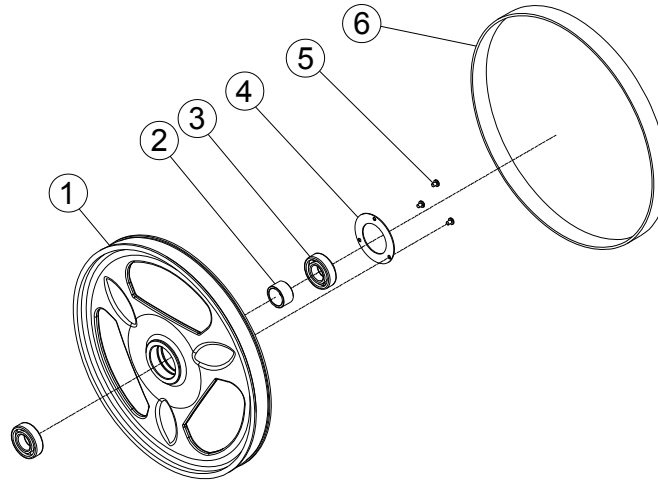

17.2.2 Upper Wheel Assembly – Parts List

Index No	Part No	Description	Size	Qty
1	PM1800B-018-01	Upper Wheel		1
	PM2013B-018-01	Upper Wheel (Rubber Coating)		1
	PM2415B-018-01	Upper Wheel (Rubber Coating)		1
2	PM1800B-018-02	Spacer		1
3	BB-6306LLU	Ball Bearing	6306LLU	2
4	PM1800B-018-04	Plate		1
5	PM1800B-018-05	Phillips Pan Head Machine Screw	M6 x 8	3
6	PM1800B-018-06	Tire		1

17.3.1 Lower Wheel Assembly – Exploded View

Part Assembly No.: PM1800B-022 (#1~8) / PM2013B-022 (#1~7) / PM2415B-022 (#1~7)

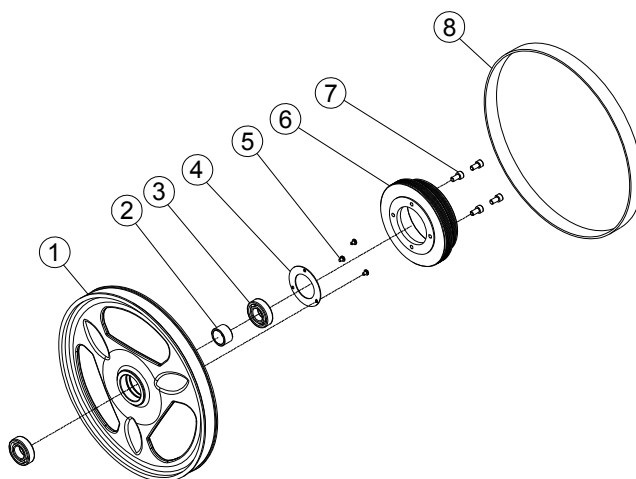

17.3.2 Lower Wheel Assembly – Parts List

Index No.	Part No.	Description	Size	Qty
1	PM1800B-022-01	Lower Wheel		1
	PM2013B-022-01	Lower Wheel (Rubber Coating)		1
	PM2415B-022-01	Lower Wheel (Rubber Coating)		1
2	PM1800B-018-02	Spacer		1
3	BB-6306LLU	Ball Bearing	6306LLU	2
4	PM1800B-018-04	Plate		1
5	PM1800B-018-05	Phillips Pan Head Machine Screw	M6 x 8	3
6	PM1800B-022-06	Pulley	ø190mm/218mm	1
7	TS-1504041	Socket Head Cap Screw	M8 x 20	4
8	PM1800B-018-06	Tire		1

17.4.1 Upper Wheel Sliding Bracket Assembly –Exploded View

Part Assembly No.: PM1800B-027 (#1~26) / PM2013B-027 (#1~7-1, 8~26) / PM2415B-027 (#1~7-2, #8~26)

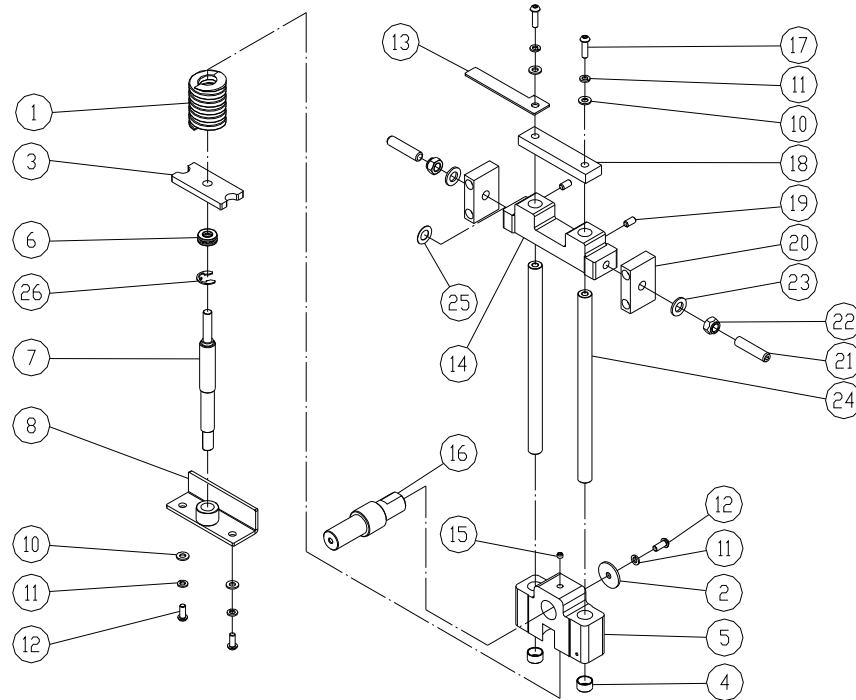

17.4.2 Upper Wheel Sliding Bracket Assembly –Part List

1	PM1800B-027-01	Spring		1
2	PM1800B-027-02	Flat Washer		1
3	PM1800B-027-03	Plate		1
4	PM1800B-027-04	Bushing	DU20 x 20	4
5	PM1800B-027-05	Upper Wheel Sliding Bracket		1
6	BB-51201	Thrust Bearing	51201	1
7	PM1800B-027-07	Adjusting Bolt	L:244mm	1
7-1	PM2013B-027-07	Adjusting Bolt	L:281mm	1
7-2	PM2415B-027-07	Adjusting Bolt	L:329mm	1
8	PM1800B-027-08	Adjust Plate Weldment		1
10	TS-1550061	Flat Washer	M8 x ø18	4
11	TS-2361081	Lock Washer	M8	5
12	TS-2248202	Hex Socket Button Head Screw	M8 x 20	3
13	PM1800B-027-13	Adjust Plate		1
14	PM1800B-027-14	Block		1
15	5302731	Set Screw	M8 x 6	1
16	PM1800B-027-16	Wheel Shaft		1
17	TS-2248302	Hex Socket Button Head Screw	M8 x 30	2
18	PM1800B-027-18	Block		1
19	TS-1525011	Socket Set Screw	M10 x 10	2
20	PM1800B-027-20	Locate Block		2
21	PM1800B-027-21	Set Screw	M14 x 60	2
22	TS-2342141	Hex Nylon Lock Nut	M14	2
23	TS-155009	Flat Washer	M14 x ø25	2
24	PM1800B-027-024	Shaft		2
25	PM1800B-027-025	Brass Washer	ø16.1 x ø23.5 x 1.0t	2
26	PM1800B-027-026	E-Ring ¹	ø15 x 1.5t	1

¹ serial no break: 1791800B from 15050014; 1791801B from 15050003; 1791257B from 15050004; 1791258B from 15050005; 1791259B from 15050005; 1791260B from 15050006.

17.5.1 Brake Linkage Assembly – Exploded View

Part Assembly No.: PM1800B-122 / PM2013B-122 / PM2415B-122

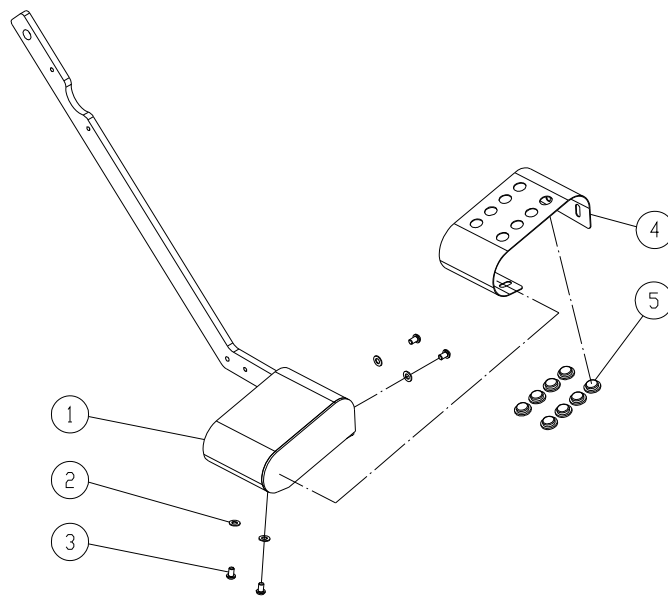

17.5.2 Brake Linkage Assembly – Parts List

Index No.	Part No.	Description	Size	Qty
1	PM1800B-122-01	Brake Arm	L:573mm	1
	PM2013B-122-01	Brake Arm	L:607mm	1
	PM2415B-122-01	Brake Arm	L:662mm	1
2	TS-1550041	Flat Washer	M6 x ϕ 13	4
3	TS-2246102	Socket Head Button Screw	M6 x 10	4
4	PM1800B-122-04	Foot Brake Cover		1
5	PM1800B-122-05	Rubber Block		8

17.12.1 Fence Assembly – Exploded View

Part Assembly No.: PM1800B-150 / PM2013B-150 / PM2415B-150

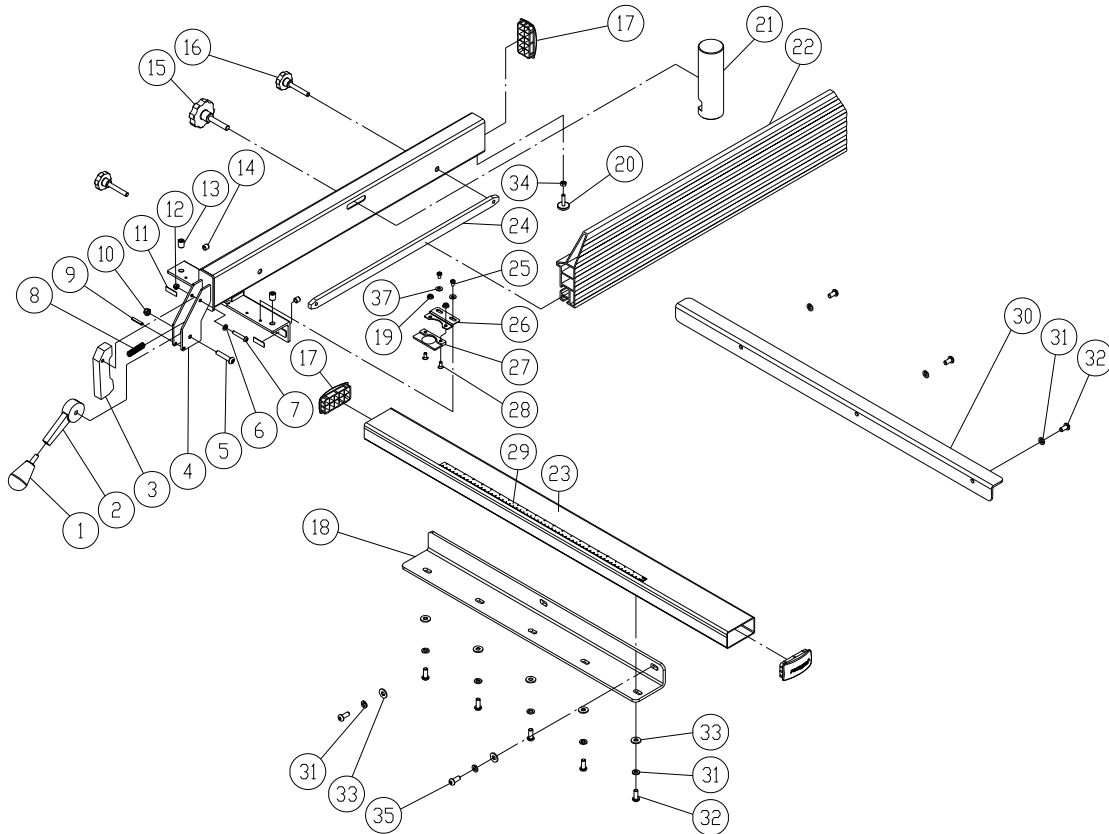

17.12.2 Fence Assembly – Parts List

Index No.	Part No.	Description	Size	Qty
1	PM1500-107-20	Knob		1
2	PM1800B-150-02	Lock Handle		1
3	PM1800B-150-03	Handle Lock Bracket		1
4	PM1800B-150-04	Fence Body		1
5	9180-56	Socket Head Button Screw	M8 x 1.25 x 35	1
6	TS-2361061	Lock Washer	M6	2
7	TS-2246352	Socket Head Button Screw	M6 x 1 x 35	1
8	PM1500-107-16	Spring		1
9	3P12312	Roll Pin	∅5 x 28	1
10	TS-1541031	Lock Nut	M8 x 1.25	1
11	PM1500-107-10	Pad	10 x 28 x 1mm	2
12	TS-1541021	Nylon Lock Hex Nut	M6	1
13	PM1800B-150-13	Nylon Set Screw	M12 x 1.75 x 16	3
14	TS-1525011	Socket Set Screw	M10 x 1.5 x 10	2
15	PM1500-107-03	Resaw Lock Knob	M10 x 50	1
16	PM1500-107-02	Lock Knob		2
17	PM1800B-150-17	Tube Plug		3
18	PM1800B-150-18	Front Rail (for 1800B & 2013B)	L:565mm	1
	PM2415B-150-18	Front Rail (for 2415B)	L:670mm	1
19	PM1500-107-22	Hex Flange Nut	M5 x 0.8	2
20	6295181	Sliding Pad		1
21	PM1800B-150-21	Resaw Pin		1
22	PM1800B-150-22	Fence Plate		1

Index No.	Part No.	Description	Size	Qty
23	PM1800B-150-23	Guide Rail (for 1800B)	L:890mm	1
	PM2013B-150-23	Guide Rail (for 2013B)	L:928mm	1
	PM2415B-150-23	Guide Rail (for 2415B)	L:1033mm	1
24	PM1800B-150-24	Lock Bar		1
25	PM1900-108-6	Phillips Pan Head Machine Screw	M5 x 0.8 x 8	2
26	PM1500-107-25	Cursor Bracket		1
27	PM1500-107-26	Convex Cursor	PC	1
28	TS-2285121	Phillips Flat Head Machine Screw	M5 x 0.8 x 12	2
29	PM1800B-150-29	Scale Label		1
30	PM1800B-150-30	Rear Rail (for 1800B & 2013B)	L:767mm	1
	PM2415B-150-30	Rear Rail (for 2415B)	L:927mm	1
31	TS-2361081	Lock Washer (for 1800B & 2013B)	M8	10
	TS-2361081	Lock Washer (for 2415B)	M8	11
32	TS-2248162	Socket Head Button Screw	M8 x 1.25 x 16	8
33	TS-1550061	Flat Washer (for 1800B & 2013B)	M8 x ϕ 20	7
	TS-1550061	Flat Washer (for 2415B)	M8 x ϕ 20	8
34	TS-1540031	Hex Nut	M5 x 0.8	2
35	TS-2248202	Socket Head Button Screw (for 1800B & 2013B)	M8 x 1.25 x 20	2
	TS-2248202	Socket Head Button Screw (for 2415B)	M8 x 1.25 x 20	3
36	TS-227D081	L type Hex Wrench (not shown)	M8	1
37	TS-1550031	Flat Washer	M5 x ϕ 10	2
	PM2415B-HP	Hardware Package (not shown), see sect. 8.1 for contents		