

# PARTS LIST: Air Control Assembly (1632 Sander)

No.	Part No.	Description	Quantity
1	6293482	Filter .....	1
2	6293483	Solenoid Valve .....	1
3	6293484	Brake Cylinder .....	1
4	6293485	Multi-Hole Connector .....	1
5	6293486	Air Valve.....	1
6	6293487	Air Sensor Assembly.....	1
7	6293488	Air Sensor.....	1
8	6293489	Switching Valve .....	1
9	6293250	Cylinder .....	1
10	6293252	Oscillator Cylinder .....	1
11	6293490	Plastic Pipe.....	1
12	6293491	Plastic Joint, PT-1/8" .....	1
13	6293492	Copper Joint .....	1
14	6293493	T-Joint .....	1
15	6293494	Silencer .....	1

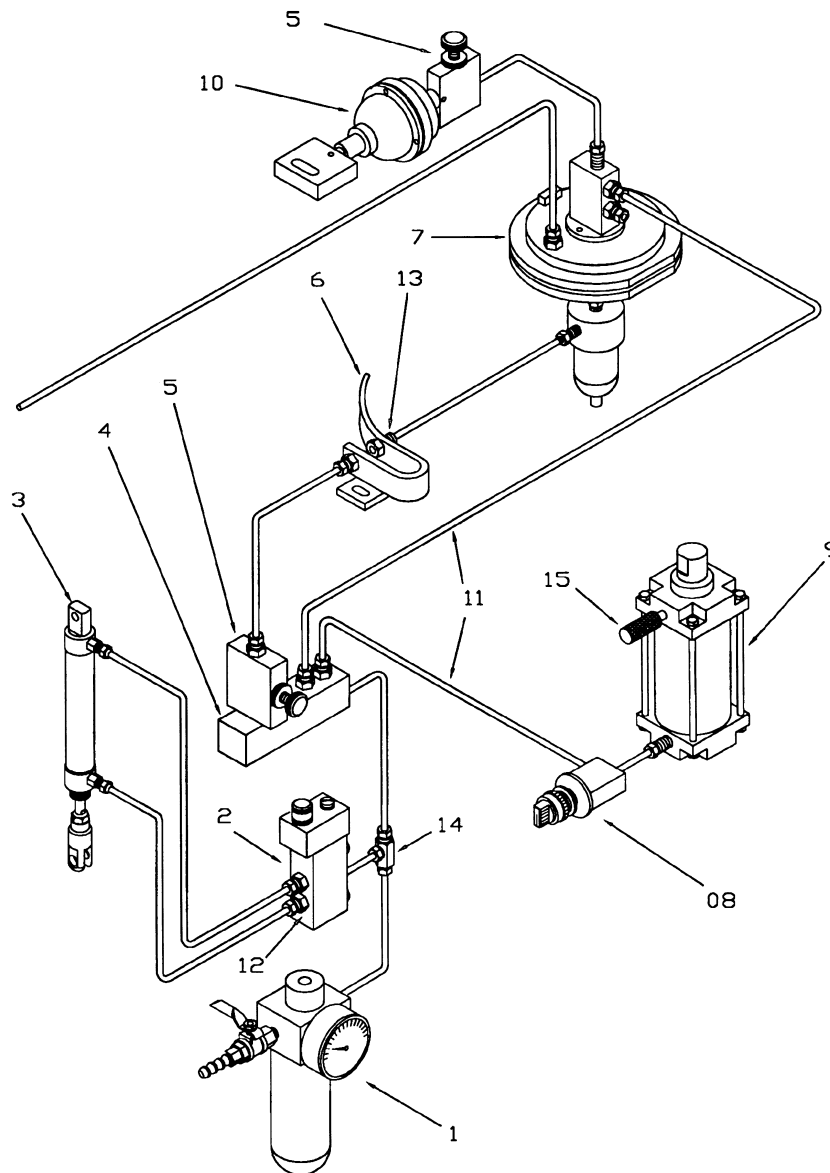

## PARTS LIST: Electricity Control & Upper Adj. Roller (1632 Sander)

No.	Part No.	Description	Quantity
1	6293203	Upper Door (L) .....	1
2	6293204	Pin for Upper Door .....	2
3	6293205	Upper Cabinet .....	1
4	6293206	Door Knob .....	2
5	6293207	Door Latch (L) .....	1
6	6293208	Upper Door (R).....	1
7	6293209	Pan Head Screw, 1/4 X 1/2.....	2
8	6293210	Flat Washer, 1/4.....	2
9	6293211	Plate .....	1
10	6293212	Hex Nut, 1/2 .....	8
11	6293213	Hex Head Screw, 3/8 X 3/4 .....	8
12	6293214	Adjust Stand (L) .....	2
13	6293215	Adjust Stand (R).....	2
14	6293216	Spring .....	4
15	6293217	Fixed Roller Stand w/ Adjust Bolt .....	4
16	6293218	Flat Washer, 3/8.....	8
17	6293219	Shaft & Rubber Roller .....	2
18	6293311	Door Latch (R).....	1
19	6293221	Ball Bearing.....	4
20	6293222	Set Screw, 1/4 X 3/4.....	4
21	6293223	Ring .....	4
22	6293224	Control Plate .....	1
23	6293225	Gear Washer, 3/16.....	6
24	6293226	Pan Head Screw, 3/16 X 3/8.....	6
25	6293227	Amp Meter .....	1
26	6293228	Feed Start Switch.....	1
	6293228	Sanding Belt Start Switch .....	1
27	6293229	Feed Stop Switch .....	1
	6293229	Sanding Belt Stop Switch .....	1
28	6293230	Stop Switch .....	1
29	6293231	Power Indicator Light.....	1
30	6293232	Current Coil.....	1
31	6293233	Fuse Stand, 5 HP .....	1
	6293312	Fuse Stand, 7-1/2 HP .....	1
32	6293234	Terminal Strip, 5 HP .....	1
	6293313	Terminal Strip, 7-1/2 HP .....	1
33	1632-233	Relay, 5 HP .....	1
	6293314	Relay, 7-1/2 HP.....	1
34	6293236	Terminal Strip, 5 HP.....	1
	6293315	Terminal Strip, 7-1/2 HP.....	1
35	1632-235	Overload Relay, 5 HP .....	1
	6293316	Overload Relay, 7-1/2 HP .....	1
36	1632-236	Relay, 5 HP .....	1
	6293317	Relay, 7-1/2 HP.....	1
37	6293239	Transformer, 5 HP.....	1
	6293318	Transformer, 7-1/2 HP.....	1

# Electricity Control & Upper Adj. Roller (1632 Sander)

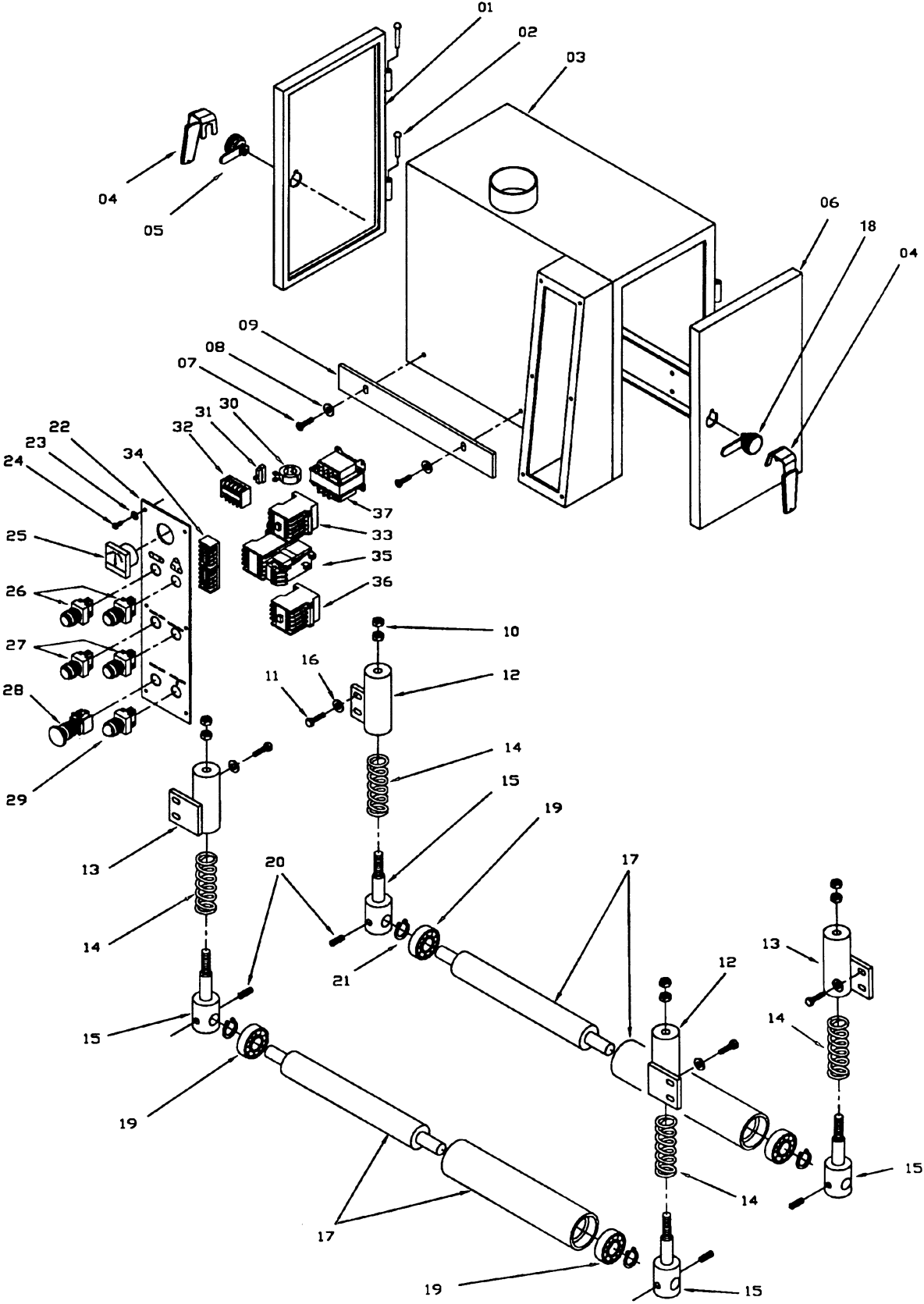

## PARTS LIST: Sanding Drum Assembly (1632 Sander)

No.	Part No.	Description	Quantity
1	6293240	Ring.....	2
2	6293241	Ball Bearing.....	2
3	6293242	Shaft.....	1
4	6293243	Upper Roller.....	1
5	6293244	Upper Roller Base (L).....	1
6	6293245	Column.....	1
7	6293246	Switch Valve.....	1
8	6293247	Eccentric Shaft Base.....	1
9	6293248	Eccentric Shaft.....	1
10	6293249	Hex Head Screw, 5/16 X 1/2.....	2
11	6293250	Air Cylinder Assembly.....	1
12	6293251	Cover (L).....	1
13	6293252	Air Oscillator Cylinder.....	1
	6293496	Air Valve Assembly (Items 14 thru 17, 74, 75, 79 & 86).....	1
14	6293253	Front Cover.....	1
15	6293254	Oscillator Shaft.....	1
16	6293255	Membrane.....	1
17	6293256	Rear Cover.....	1
18	6293257	Column.....	1
19	6293258	Cover (R).....	1
20	6293259	Air Sensor.....	1
	6293497	Air Valve Assembly (Items 21 thru 26 & 79).....	1
21	6293260	Lower Cover.....	1
22	6293261	Air Sensor Substance.....	1
23	6293262	Piston.....	1
24	6293263	Upper Cover.....	1
25	6293264	Plastic Joint Assembly.....	1
26	6293265	Membrane.....	1
27	6293266	Handle Assembly.....	1
28	6293267	Set Screw, 1/4 X 1/4.....	1
29	6293268	Handle Hub.....	1
30	6293269	Hex Head Screw, 3/8 X 1-1/4.....	4
31	6293270	Adjust Bolt, 3/8 X 1-1/4.....	2
32	6293271	Spring.....	2
33	6293272	Shaft.....	1
34	6293273	Key, 5 X 5 X 30.....	2
35	6293274	Key, 8 X 8 X 40.....	1
36	6293275	Lock Handle.....	1
37	6293276	Knob.....	1
38	6293277	Hex Head Screw, 3/8 X 1-1/2.....	2
39	6293278	Pan Head Screw, 5/32 X 3/8.....	6
40	6293279	Hex Socket Cap Screw, 1/4 X 1/2.....	12
41	6293280	Bearing Cover.....	2
42	6293281	Bearing Cover (L).....	1
	6293282	Bearing Cover (R).....	1
43	6293283	Lock Nut (counter-clockwise).....	2
44	6293284	Lock Nut (clockwise).....	1
45	6293285	Ball Bearing.....	4
46	6293286	Round Bearing Frame.....	1
47	6293287	Main Rubber Roller.....	1
48	6293288	Hex Head Screw, 5/16 X 1-3/4.....	2
49	6293289	Hex Nut, 5/16.....	2
50	6293290	Back Steel Roller.....	1
51	6293291	Blanket.....	1
52	6293292	Pad Slider.....	1
53	6293293	Hex Head Screw, 3/8 X 1.....	2

**PARTS LIST: Sanding Drum Assembly (1632 Sander) continued**

<b>No.</b>	<b>Part No.</b>	<b>Description</b>	<b>Quantity</b>
54	6293294	Pad.....	1
55	6293218	Flat Washer, 3/8.....	2
56	6293295	Pressing Bar.....	2
57	6293296	Graphite Canvas.....	1
58	6293297	Pulley (5 HP).....	1
	6293298	Pulley (7-1/2 HP).....	1
59	6293299	Flat Washer, 5/16.....	1
60	6293300	Hex Head Screw, 5/16 X 1.....	1
61	6293301	Rectangular Bearing Base.....	1
62	6293302	Cover.....	1
63	6293303	Air Sensor Assembly.....	1
64	6293304	Limit Switch.....	2
65	6293305	Disk.....	1
66	6293306	Hex Head Screw, 1/4 X 3/8.....	1
67	6293210	Flat Washer, 1/4.....	1
68	6293330	Pan Head Screw, 5/32 X 1/2.....	2
69	6293331	Pan Head Screw, 5/32 X 1.....	2
70	6293332	Hex Head Screw, 5/16 X 2.....	4
71	6293333	Cap Screw, M8 X 20.....	4
72	6293334	Hex Head Screw, 1/4 X 2.....	4
73	6293209	Pan Head Screw, 1/4 X 1/2.....	6
74	6293335	Air Valve.....	1
75	6293336	Block Connector.....	1
76	6293337	Knob.....	1
77	6293338	Cylinder Disk.....	1
78	6293339	Eccentric Roller.....	2
79	6293340	Pan Head Screw, 3/16 X 5/8.....	8
80	6293341	Gear Washer, 5/16.....	4
81	6293342	Gear Washer, 3/8.....	4
82	6293343	Flat Washer, 5/32.....	1
83	6293344	Spring Washer, 3/8.....	2
84	6293345	Hex Nut.....	1
85	6293346	Hex Head Screw, 1/4 X 1/2.....	1
86	6293347	Spring Pin, 3 X 16.....	1
87	6293348	Gear Washer, 1/4.....	4
88	6293349	Gear Washer, M8.....	4
89	6293350	Spring Washer, 1/4.....	1
90	6293501	Upper Roller Base (R).....	1

# Sanding Drum Assembly (1632 Sander)

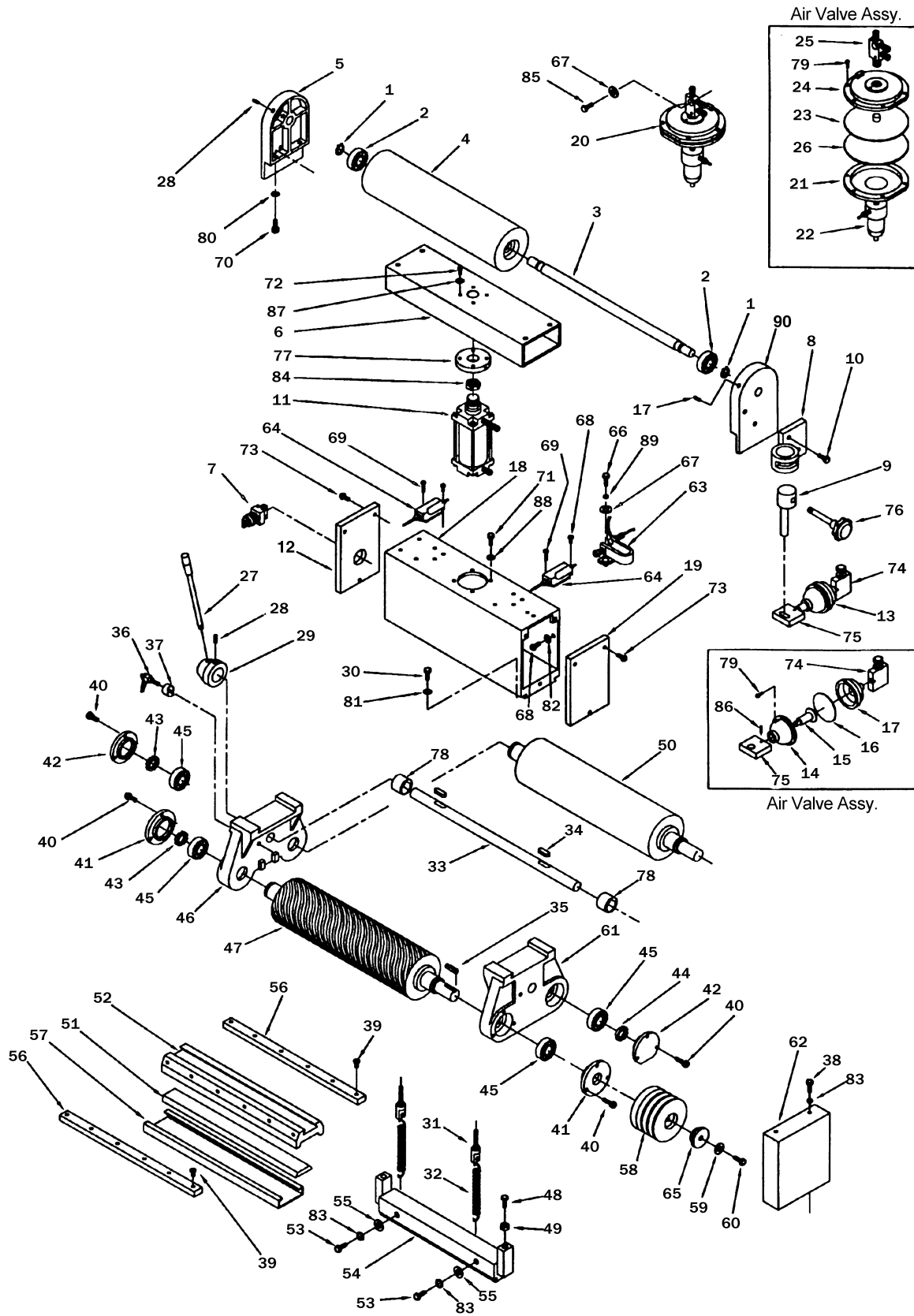

## PARTS LIST: Base & Table Adjust Assembly (1632 Sander)

No.	Part No.	Description	Quantity
1	6293240	Ring.....	2
1	6293415	Door .....	1
2	6293416	Crosspiece.....	1
3	6293417	Door Knob .....	1
4	6293418	Cover.....	1
5	6293419	Hex Head Screw, 1/4 X 1.....	4
6	6293420	Base .....	1
7	6293421	Cover.....	1
8	6293422	Hex Head Screw, 3/16 X 3/8.....	4
9	6293423	Flat Washer, 3/16 .....	4
10	1632-410	Motor (5 HP, 1 PH) .....	1
	6293425	Motor (7-1/2 HP, 3 PH) .....	1
11	6293293	Hex Head Screw, 3/8 X 1 .....	4
12	6293426	Lock Washer, 3/8.....	4
13	6293427	Brake Base .....	1
14	6293428	Brake Pole.....	1
15	6293429	Brake Spring.....	2
16	6293430	Brake.....	2
17	6293431	Bolt, 5/16 X 1-1/2.....	1
18	6293432	Bolt, 1/2 .....	1
19	6293433	Socket Head Screw, 5/16 X 1/2.....	6
20	6293434	Bolt, 3/8 X 1-1/2.....	1
21	1632-421	Pulley (5 HP) .....	1
	6293436	Pulley (7-1/2 HP) .....	1
22	6293210	Flat Washer, 1/4 .....	1
23	6293437	Hex Head Screw, 1/4 X 1 .....	1
24	1632-424	Motor Plate (5 HP).....	1
	6293439	Motor Plate (7-1/2 HP).....	1
25	6293212	Hex Nut, 1/2 .....	1
26	6293440	Base .....	1
27	6293441	Set Screw, 5/16 X 1 .....	4
28	6293442	Hex Socket Cap Screw, 5/16 X 1-1/2 .....	4
29	6293299	Flat Washer, 5/16 .....	1
30	1632-430	Belt, A-84.....	2
31	6293444	Flat Head Screw, 1/4 X 1/2 .....	2
32	6293445	Key, 19 X 3/8 X 270 .....	1
33	6293446	Base Lifting Pipe.....	1
34	6293447	Cap Screw, 3/4 .....	1
35	6293249	Hex Head Screw, 5/16 X 1/2 .....	4
36	6293341	Gear Washer, 5/16 .....	4
37	6293448	Spring Pin, 5 X 25.....	1
38	6293449	Lock Handle.....	1
39	6293450	Hex Nut, 1/4 .....	2
40	6293451	Bolt, 1/4 X 290mm .....	1
41	6293452	Lock Washer, 1/4.....	1
42	6293453	Gear .....	1
43	6293454	Ring.....	1
44	6293455	Ball Bearing.....	2
45	6293456	Bolt, 3/8 X 4.....	2
46	6293457	Hex Nut, 3/8 .....	6
47	6293218	Flat Washer, 3/8 .....	4
48	6293458	Hex Head Screw, 3/8 X 1-3/4.....	4
49	6293459	Ring.....	1
50	6293460	Gear Box .....	1
51	6293461	Ball Bearing.....	2
52	6293462	Worm Gear.....	1

**PARTS LIST: Base & Table Adjust Assembly (1632 Sander) continued**

<b>No.</b>	<b>Part No.</b>	<b>Description</b>	<b>Quantity</b>
53	6293218	Flat Washer, 3/8.....	4
54	6293463	Shaft .....	1
55	6293267	Set Screw, 1/4 X 1/4.....	2
56	6293464	Set Screw, 1/4 X 1.....	1
57	6293450	Hex Nut, 1/4.....	1
58	6293465	Wheel, 8" .....	1
59	6293466	Handle .....	1
60	6293209	Pan Head Screw, 1/4 X 1/2.....	2
61	6293467	Lower Guard .....	1
62	6293468	Upper Guard .....	1
63	6293277	Hex Head Screw, 3/8 X 1-1/2 .....	8
64	6293342	Gear Washer, 3/8.....	8
65	6293469	Air Cylinder Assembly .....	1
66	6293300	Hex Head Screw, 5/16 X 1 .....	2
67	6293289	Hex Nut, 5/16".....	2
68	6293470	Key (7-1/2 HP), 10 X 8 X 60 .....	1
	6293471	Key (5 HP) .....	1
69	6293472	Cover .....	1
70	6293210	Flat Washer 1/4.....	2
71	6293457	Hex Nut, 3/8.....	1
72	6293473	Solenoid Valve .....	1
73	6293331	Pan Head Screw, 5/32 X 1.....	2
74	6293474	Filter.....	1
75	6293475	Pan Head Screw, 5/32 X 1-3/8.....	1
76	6293476	Hookup Box .....	1
77	6293477	Screw, 3/16 X 1-3/8.....	2
78	6293478	Flat Washer, 3/16.....	2
79	6293479	Hex Nut 3/16 .....	2
80	6293210	Flat Washer, 1/4.....	4
81	6293480	Screw Lead, 3/4 .....	1
82	6293481	Lifting Pipe .....	1



# Base & Table Adjust Assembly (1632 Sander)

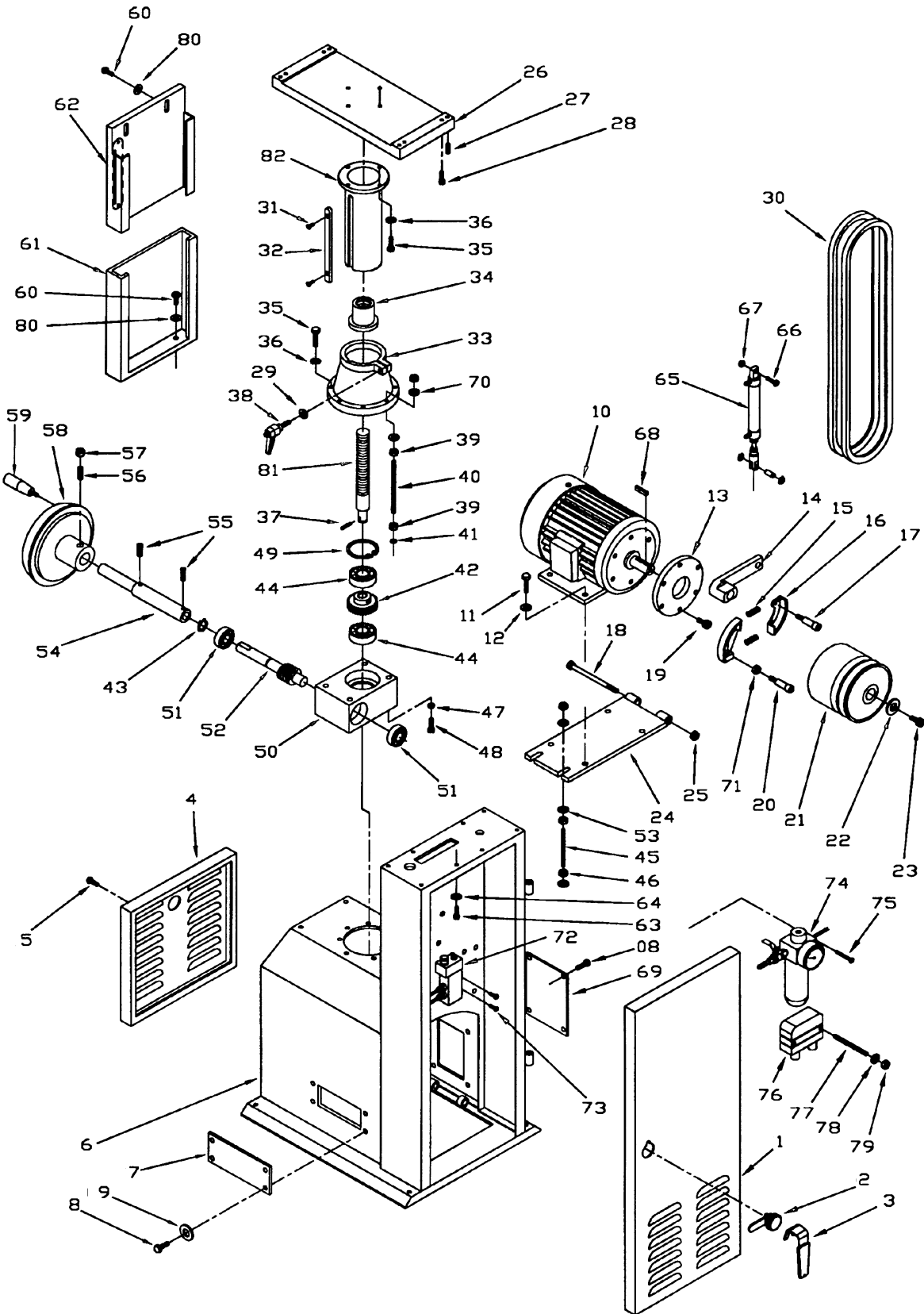

## PARTS LIST: Conveyor Belt & Table; Reduction Motor (1632 Sander)

No.	Part No.	Description	Quantity
1	6293351	Hex Socket Cap Screw, 1/4 X 1/4.....	6
2	6293352	Bearing Cover .....	2
3	6293353	Ball Bearing.....	2
4	6293354	Back Conveyor Roller Base (L) .....	1
5	6293355	Roller .....	1
6	6293356	Key, 6 X 6 X 20 .....	1
7	6293357	Back Conveyor Roller & Motor Base .....	1
8	6293358	Key, 5 X 5 X 25 .....	1
9	6293267	Set Screw, 1/4 X 1/4.....	4
10	6293359	Chain .....	1
11	6293360	Sprocket.....	1
12	6293332	Hex Head Screw, 5/16 X 2 .....	5
13	6293361	Cover.....	1
14	6293362	Hex Socket Cap Screw, 1/4 X 2.....	1
15	6293495	Reduction Motor Assembly, 1 Ph (Items 16 thru 38).....	1
	6293498	Reduction Motor Assembly, 3 Ph (Items 16 thru 38).....	1
16	6293363	Body.....	1
17	6293364	Gear B, 40T .....	1
18	6293365	Gear A, 19T .....	1
19	6293366	Ball Bearing.....	4
20	6293367	Gear B, 47T .....	1
21	6293368	Gear C, 14T .....	1
22	6293369	Output Shaft.....	1
23	6293370	Key, 5 X 5 X 10 .....	1
24	6293371	Gear D, 46T .....	1
25	6293372	Washer .....	1
26	6293373	Ball Bearing.....	1
27	6293374	Oil Seal, 20, 35, 7 .....	1
28	6293375	Rear Cover.....	1
29	6293376	Oil Seal, 12, 22, 5 .....	1
30	6293377	Needle Bearing, 1012.....	1
31	6293378	Washer .....	1
32	6293379	O-Ring .....	1
33	6293380	Fixing Screw .....	3
34	6293381	Gear A, 8T .....	1
35	6293382	Motor, 1/4 HP, 1 PH.....	1
	6293220	Motor, 1/4 HP, 3 PH.....	1
36	6293358	Key, 5 X 5 X 25 .....	1
37	6293383	Motor Label .....	1
38	6293384	Key, 4 X 4 X 10 .....	2
39	6293385	Hex Head Screw, 5/16 X 3/8.....	6
40	6293386	Sprocket.....	1
41	6293289	Hex Nut, 5/16 .....	4
42	6293341	Gear Washer, 5/16.....	8
43	6293299	Flat Washer, 5/16.....	8
44	6293249	Hex Head Screw, 5/16 X 1/2.....	4
45	6293387	Flat Head Screw, 5/32 X 1 .....	4
46	6293388	Stop Plate .....	1
47	6293277	Hex Head Screw, 3/8 X 1-1/2 .....	2
48	6293218	Flat Washer, 3/8.....	4
49	6293389	Shaft .....	2
50	6293331	Pan Head Screw, 5/32 X 1.....	8
51	6293390	Shaft Base .....	2
52	6293391	Wing Screw, 1/4 X 1/2.....	2
53	6293392	Conveyor Belt .....	1
54	6293393	Working Table.....	1

**PARTS LIST: Conveyor Belt & Table; Reduction Motor (1632 Sander) continued**

No.	Part No.	Description	Quantity
55	6293289	Hex Nut, 5/16.....	2
56	6293394	Spring Washer, 5/16.....	8
57	6293300	Hex Head Screw, 5/16 X 1.....	8
58	6293395	Stop Plate Annex.....	2
59	6293396	PVC Roller.....	2
60	6293397	Hex Head Screw, 5/16 X 1-1/2.....	2
61	6293398	Ring.....	2
62	6293241	Ball Bearing.....	2
63	6293399	Adjust Bolt, 3/8 X 1-1/2.....	2
64	6293400	Roller.....	1
65	6293401	Shaft.....	1
66	6293402	Roller Base (L).....	1
67	6293403	Roller Base (R).....	1
68	6293404	Roller Frame (L).....	2
69	6293405	Roller Frame (R).....	2
70	6293406	Roller.....	2
71	6293407	Pan Head Screw, 5/32 X 1-3/4.....	2
72	6293408	Front Plate.....	1
73	6293409	Limit Switch.....	1
74	6293330	Pan Head Screw, 5/32 X 1/2.....	1
75	6293410	Bakelite.....	1
76	6293411	Hex Head Screw, 3/8 X 1/2.....	2
77	6293212	Hex Nut, 1/2.....	8
78	6293412	Bolt, 1/2 X 1-3/8.....	8
79	6293331	Pan Head Screw, 5/32 X 1.....	1
80	6293413	Spring Washer, 1/2.....	8
81	6293414	Flat Washer.....	5
82	6293500	Roller.....	2

# Conveyor Belt & Table (1632 Sander)

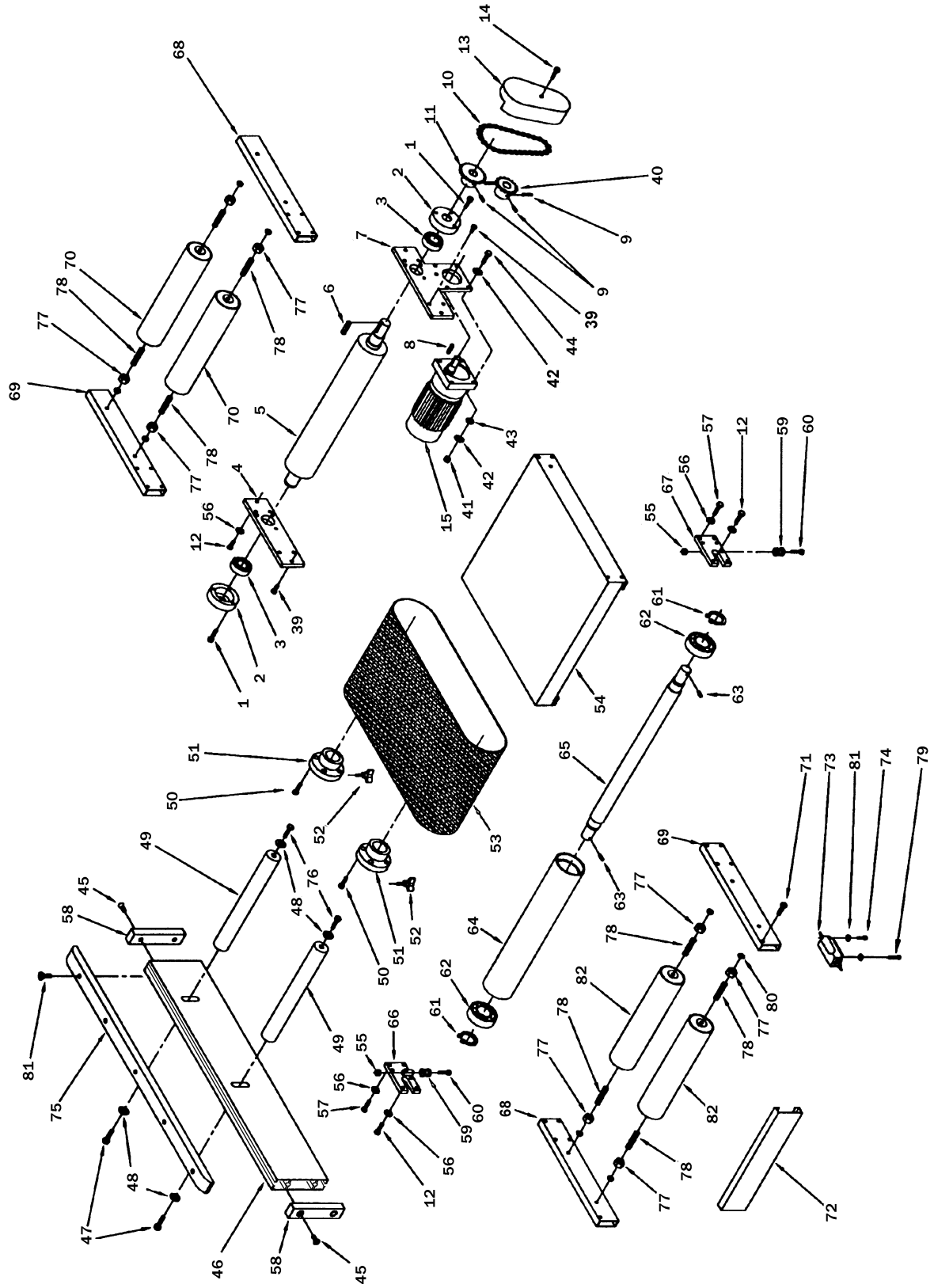

# Reduction Motor (1632 Sander)

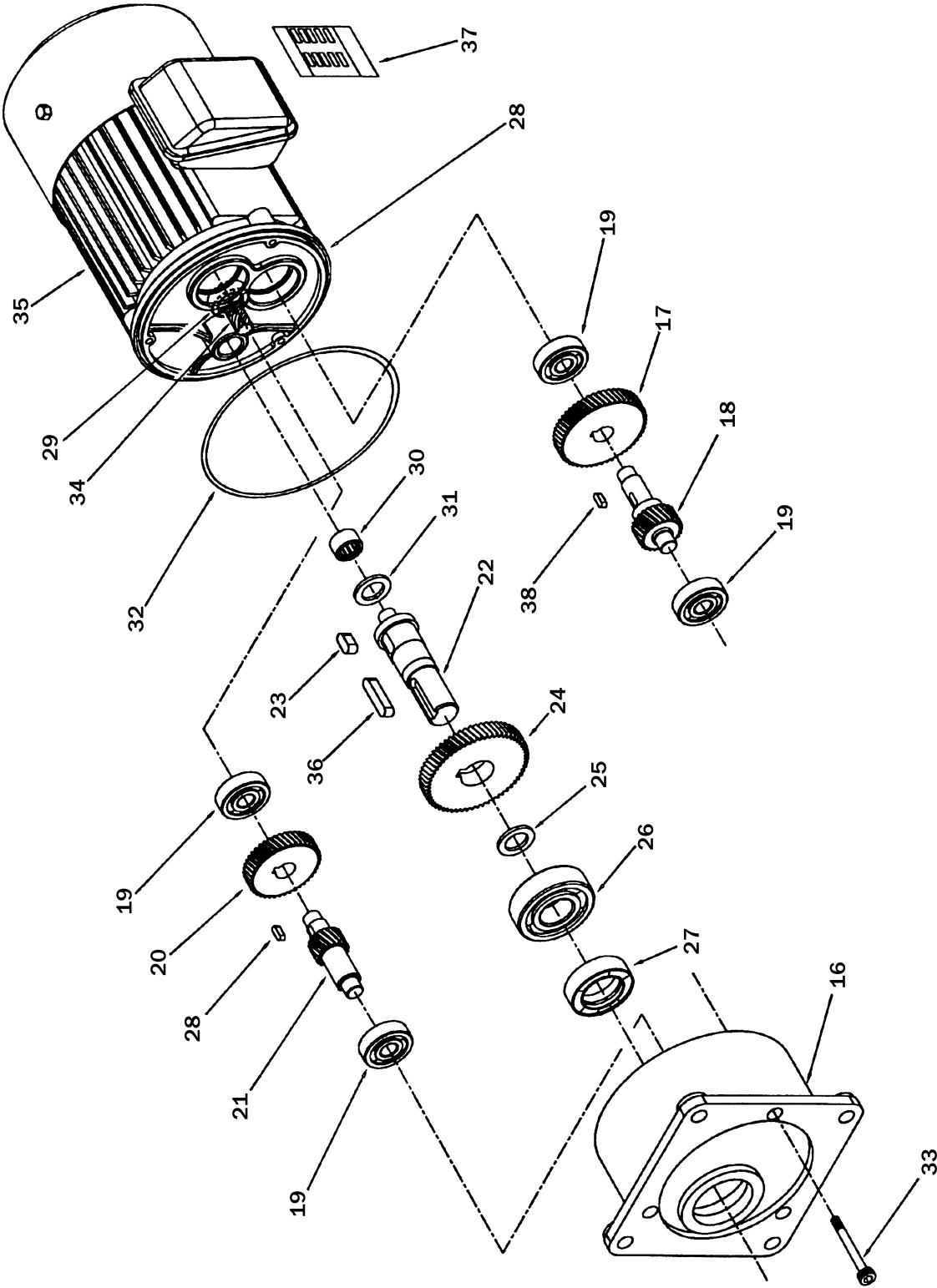

# ELECTRICAL SCHEMATIC (1632 Sander)

460V – 3 Phase

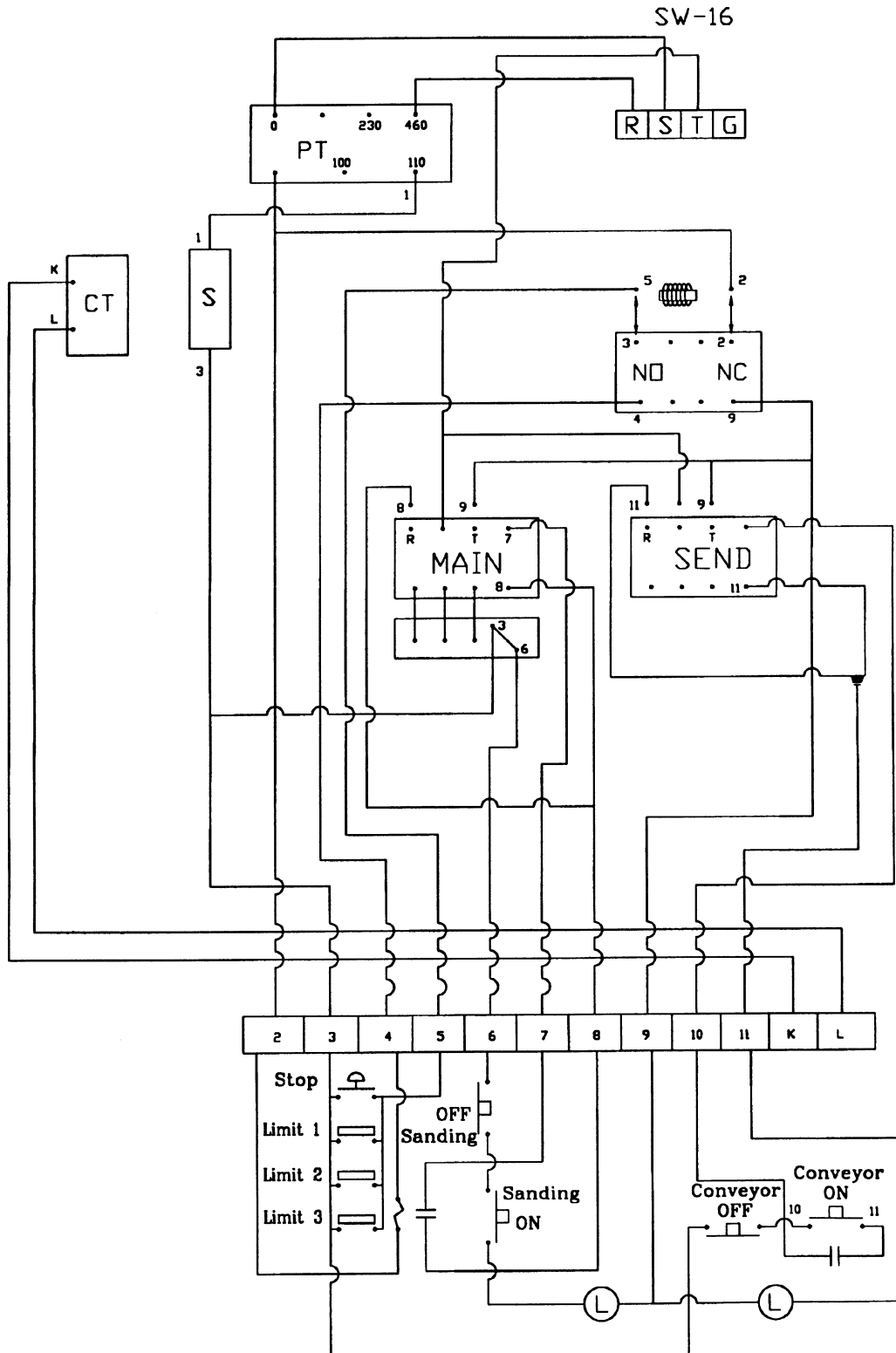

# ELECTRICAL SCHEMATIC (1632 Sander)

230V – 1 Phase / 3 Phase

