

16.1.1 Table and Cabinet Assembly – Exploded View

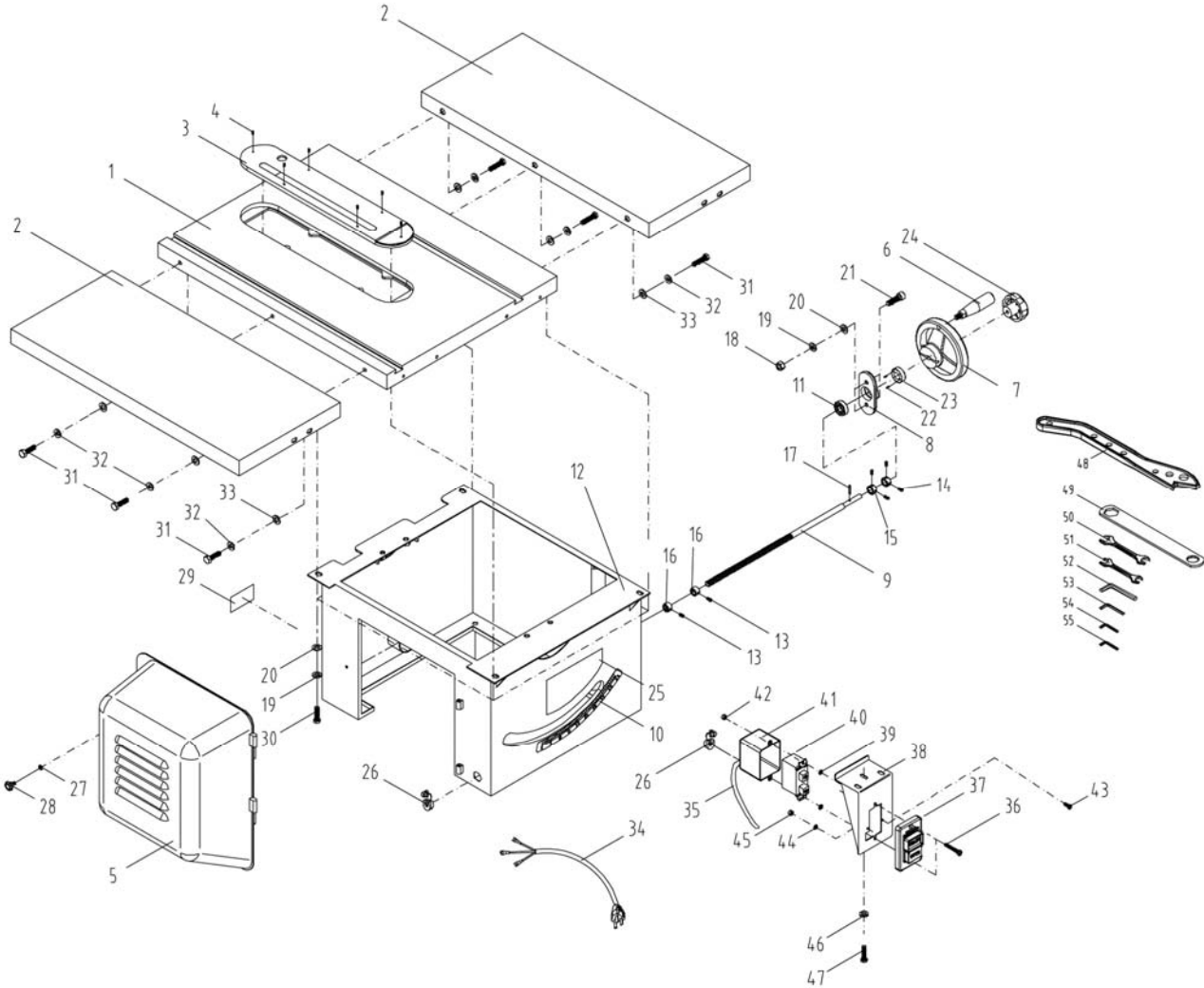

## 16.1.2 Table and Cabinet Assembly – Parts List

Index No	Part No	Description	Size	Qty
1	64B-101	Table		1
2	64B-102	Table Extension		2
	64B-TIA	Table Insert Assembly (#3 thru #4)		1
3	64B-103	Table Insert		1
4	TS-1522011	Socket Set Screw	M5x5	6
5	64B-105	Cover		1
6	3520B-126	Handle		1
7	64B-107	Handwheel		1
8	64B-108	Cover Plate		1
9	64B-109	Lead Screw		1
10	64B-110	Angle Scale		1
11	BB-6201ZZ	Ball Bearing	6201ZZ	1
12	64B-112	Cabinet		1
13	TS-1523021	Socket Set Screw	M6x8	4
14	TS-1523011	Socket Set Screw	M6x5	4
15	64B-115	Bushing		2
16	64B-116	Bushing		2
17	64B-117	Spring Pin	Ø4x25 mm	1
18	TS-1540061	Hex Nut	M8	2
19	TS-2361081	Lock Washer	M8	6
20	TS-1550061	Flat Washer	M8	6
21	TS-1504071	Socket Head Cap Screw	M8x35	2
22	64B-122	Spring Pin	Ø3x12 mm	2
23	64B-123	Lock Bushing		1
24	64B-124	Lock Knob		1
25	LM000636	Warning Label		1
26	6290630	Strain Relief	7W-2	3
27	TS-1550031	Flat Washer	M5	1
28	64B-128	Lock Knob		1
29	64B-129	I.D label		1
30	TS-1490031	Hex Cap Screw	M8x20	4
31	TS-1491041	Hex Cap Screw	M10x30	6
32	TS-2361101	Lock Washer	M10	6
33	TS-1550071	Flat Washer	M10	6
34	64B-134	Power Cord		1
35	64B-135	Motor Cord		1
36	TS-081C082	Phillips Pan Head Machine Screw	#10-24x1-1/2"	2
37	6296133	Switch Push Button		1
38	6291367	Switch Bracket		1
39	TS-0733031	Star Washer	#10	2
40	6296128	Switch		1
41	6291366	Switch Box		1
42	TS-0560071	Hex Nut	#10-24	2
43	TS-1533032	Phillips Pan Head Machine Screw	M5x10	2
44	TS-0733041	Star Washer	1/4"	2
45	TS-1540031	Hex Nut	M5	2
46	TS-0720071	Lock Washer	1/4"	1
47	TS-0050031	Hex Cap Screw	1/4"-20x3/4"	1
48	JPS10TSR-103	Push Block		1
49	6290642	Arbor Wrench		1
50	JBOS5-105	Open End Wrench	#14-#17	1
51	JBOS5-106	Open End Wrench	#10-#12	1
52	TS-152707	Hex Key	6mm	1
53	TS-152705	Hex Key	4mm	1
54	TS-152704	Hex Key	3mm	1
55	JPS10TSR-105	Hex Key	2.5mm	1
	64B-HP	Hardware Package (includes #31-33)		1

### 16.2.1 Motor and Trunnion Assembly – Exploded View

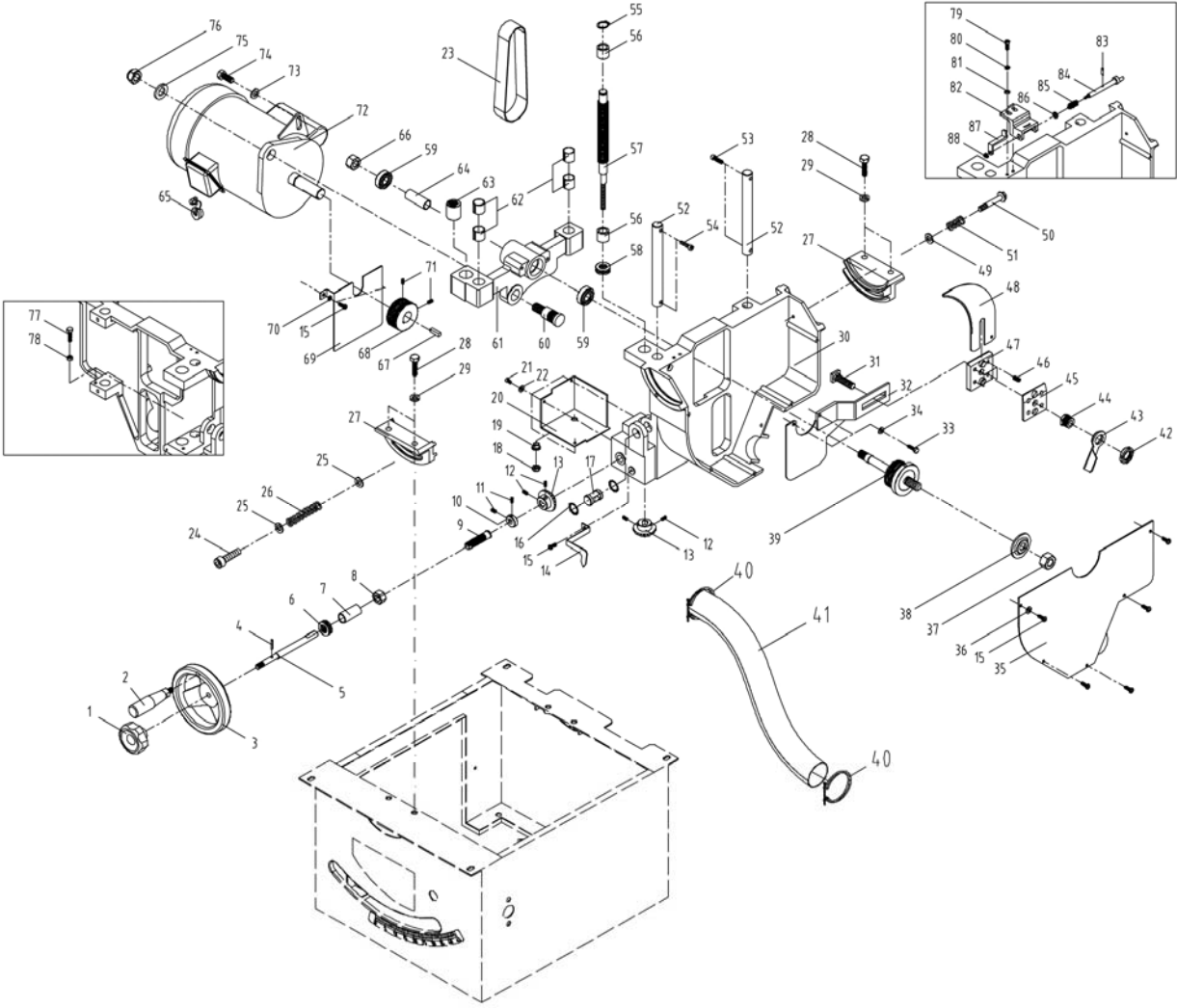

## 16.2.2 Motor and Trunnion Assembly – Parts List

Index No	Part No	Description	Size	Qty
1	64B-124	Lock Knob		1
2	3520B-126	Handle		1
3	64B-107	Handwheel		1
4	64B-117	Spring Pin	Ø4x25 mm	1
5	64B-205	Lead Screw		1
6	64B-206	Thrust Bearing	51104	1
7	64B-207	Bushing		1
8	TS-154012	Hex Nut	M20-2.5P	1
9	64B-209	Bushing		1
10	64B-210	Spacer		1
11	TS-1522031	Socket Set Screw	M5x10	2
12	TS-0267041	Socket Set Screw	1/4"-20x3/8"	4
13	64B-213	Gear		2
14	64B-214	Pointer		1
15	TS-1533052	Phillips Pan Head Machine Screw	M5x15	8
16	64B-216	Lock Washer		2
17	64B-217	Guide Shaft		1
18	TS-1541031	Nylon Lock Hex Nut	M8	1
19	64B-219	Bearing		1
20	64B-220	Gear Cover		1
21	TS-1532042	Phillips Pan Head Machine Screw	M4x12	3
22	TS-1550021	Flat Washer	M4	3
23	64B-223	Poly-V Belt	188J	1
24	64B-224	Socket Head Cap Screw	M8x65	1
25	TS-1550061	Flat Washer	M8	2
26	64B-226	Spring		1
27	64B-227	Trunnion		2
28	TS-1491031	Hex Cap Screw	M10x25	4
29	TS-2361101	Lock Washer	M10	4
30	64B-230	Center Trunnion		1
31	64B-231	Screw		1
32	64B-232	Support Base		1
33	TS-1482031	Hex Cap Screw	M6x16	2
34	TS-1550041	Flat Washer	M6	2
35	64B-235	Cover		1
36	TS-1550031	Flat Washer	M5	5
37	6290693	Arbor Nut		1
38	6290598	Flange		1
39	64B-239	Arbor		1
40	64B-240	Clamp	3"	2
41	64B-241	Hose		1
42	64B-242	Nut		1
43	64B-243	Lock Handle		1
44	64B-244	Bolt		1
45	64B-245	Holding Plate		1
46	TS-1524011	Socket Set Screw	M8x8	4
47	64B-247	Support Base		1
48	64B-248	Low Profile Riving Knife		1
49	TS-1550041	Flat Washer	M6	1
50	64B-250	Bolt		1
51	64B-251	Spring		1
52	64B-252	Moving Rod		2
53	TS-1504041	Socket Head Cap Screw	M8x20	2
54	TS-1504071	Socket Head Cap Screw	M8x35	2
55	64B-255	S-Ring	S15	1
56	64B-256	Bushing		2
57	64B-257	Lead Screw		1

Index No	Part No	Description	Size	Qty
58	64B-258	Thrust Bearing		1
59	BB-6202VV	Ball Bearing	6202LU	2
60	64B-260	Shaft		1
61	64B-261	Bracket		1
62	64B-262	Bearing		4
63	64B-263	Thread Housing		1
64	64B-264	Bushing		1
65	6290630	Strain Relief	7W-2	1
66	64B-266	Hex Nut (L.H Thread)	M14-2.0P	1
67	64B-267	Key	5x5x25 mm	1
68	64B-268	Motor Pulley		1
69	64B-269	Plate		1
70	TS-2361051	Lock Washer	M5	2
71	TS-1523031	Socket Set Screw	M6x10	2
72	64B-272	Motor		1
	64B-272MF	Motor Fan (not shown)		1
	64B-272MFC	Motor Fan Cover (not shown)		1
	64B-272CS	Centrifugal Switch (not shown)		1
	64B-272SCC	Starting Capacitor Cover (not shown)		1
	64B-272RCC	Running Capacitor Cover (not shown)		1
	64B-272SC	Starting Capacitor (not shown)	400MFD, 125VAC	1
	64B-272RC	Running Capacitor (not shown)	30µf, 250VAC	1
	64B-272JB	Junction Box (not shown)		1
	64B-272JBC	Junction Box Cover (not shown)		1
	64B-272OL	Overload (not shown)		1
	64B-272DC	Dust Cover (not shown)		1
73	TS-1550071	Flat Washer	M10	1
74	TS-1491031	Hex Cap Screw	M10x25	1
75	TS-0680081	Flat Washer	5/8"	1
76	64B-276	Nylon Lock Hex Nut	5/8"-11	1
77	TS-1482061	Hex Cap Screw	M6x30	2
78	TS-2311061	Hex Nut	M6	2
	64B-ALA	Arbor Lock Assembly (82# thru 88#)		1
79	TS-1502041	Socket Head Cap Screw	M5x16	2
80	TS-2361051	Lock Washer	M5	2
81	TS-1550031	Flat Washer	M5	2
82	64B-282	Bracket		1
83	64B-283	Spring Pin	Ø3x25 mm	1
84	64B-284	Lock Shaft		1
85	64B-285	Spring		1
86	TS-1550061	Flat Washer	M8	1
87	64B-287	Handle		1
88	TS-1541001	Hex Nylon Lock Nut	M4	1

### 16.3.1 Stand Assembly – Exploded View

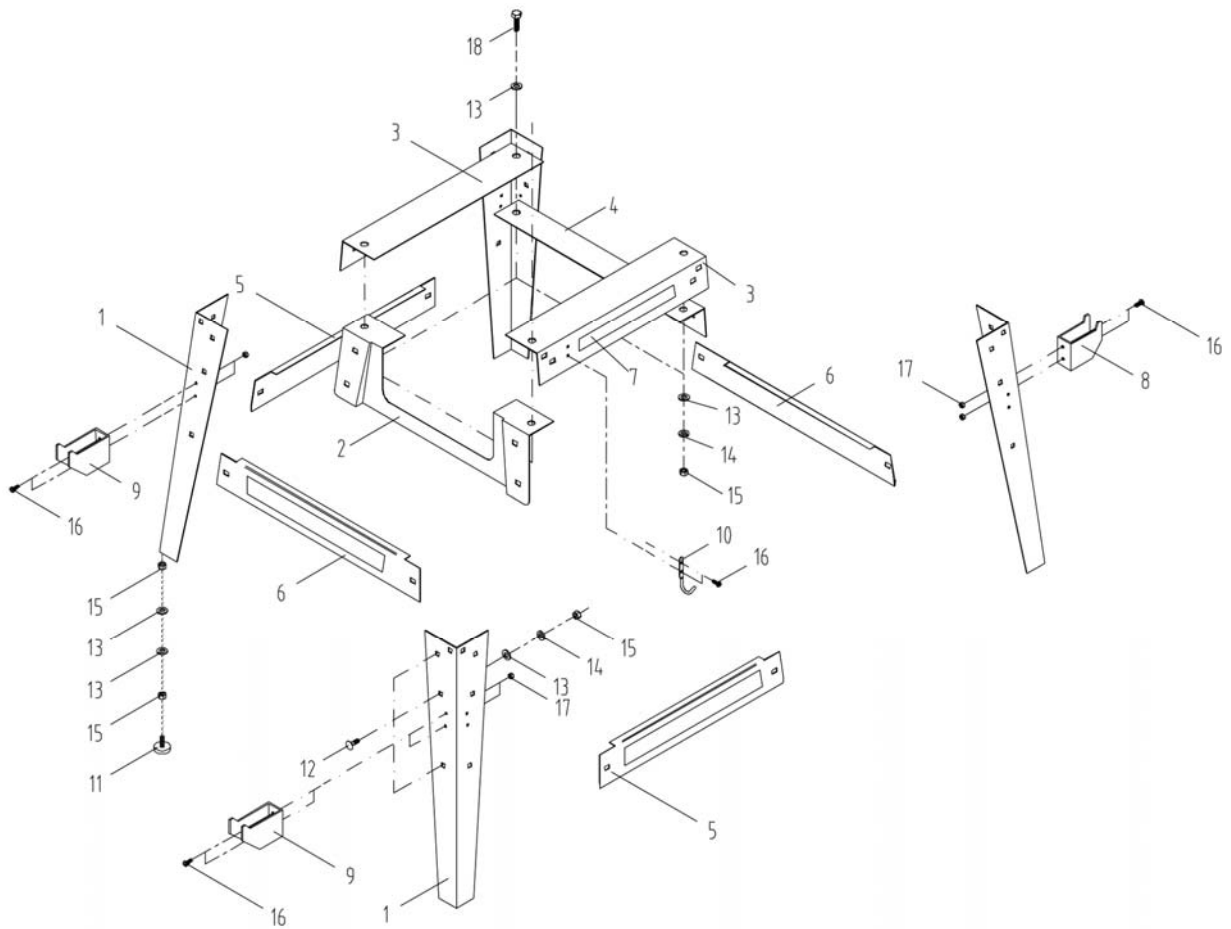

### 16.3.2 Stand Assembly – Parts List

Index No	Part No	Description	Size	Qty
1.....	64B-301	Leg.....		4
2.....	64B-302	Upper Side Brace.....		1
3.....	64B-303	Upper Short Brace.....		2
4.....	64B-304	Upper Long Brace.....		1
5.....	64B-305	Lower Short Brace (includes stripe).....		2
6.....	64B-306	Lower Long Brace (includes stripe).....		2
7.....	64B-307	Powermatic Nameplate Label.....	1-1/2"W x 10"L	1
8.....	64B-308	Miter Gauge Hook.....		1
9.....	64B-309	Fence Body Hook.....		2
10.....	64B-310	Hook.....		1
11.....	64B-311	Rubber Foot Pad.....		4
12.....	64B-312	Carriage Bolt.....	M8x16	24
13.....	TS-1550061	Flat Washer.....	M8	40
14.....	TS-2361081	Lock Washer.....	M8	28
15.....	TS-1540061	Hex Nut.....	M8	36
16.....	TS-1533052	Phillips Pan Head Machine Screw.....	M5x15	8
17.....	TS-1540031	Hex Nut.....	M5	8
18.....	TS-1490031	Hex Cap Screw.....	M8x20	4
.....	64B-SHP	Stand Hardware Package (#12 thru #18).....		1
.....	3520B-158	Black Stripe.....		per ft.

16.4.1 Blade Guard and Miter Gauge Assemblies – Exploded View

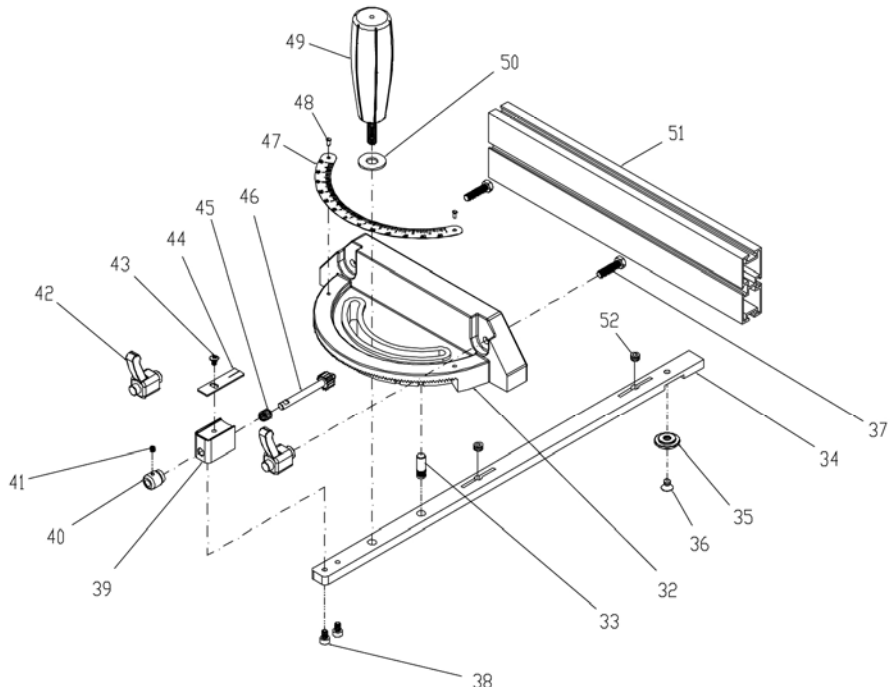
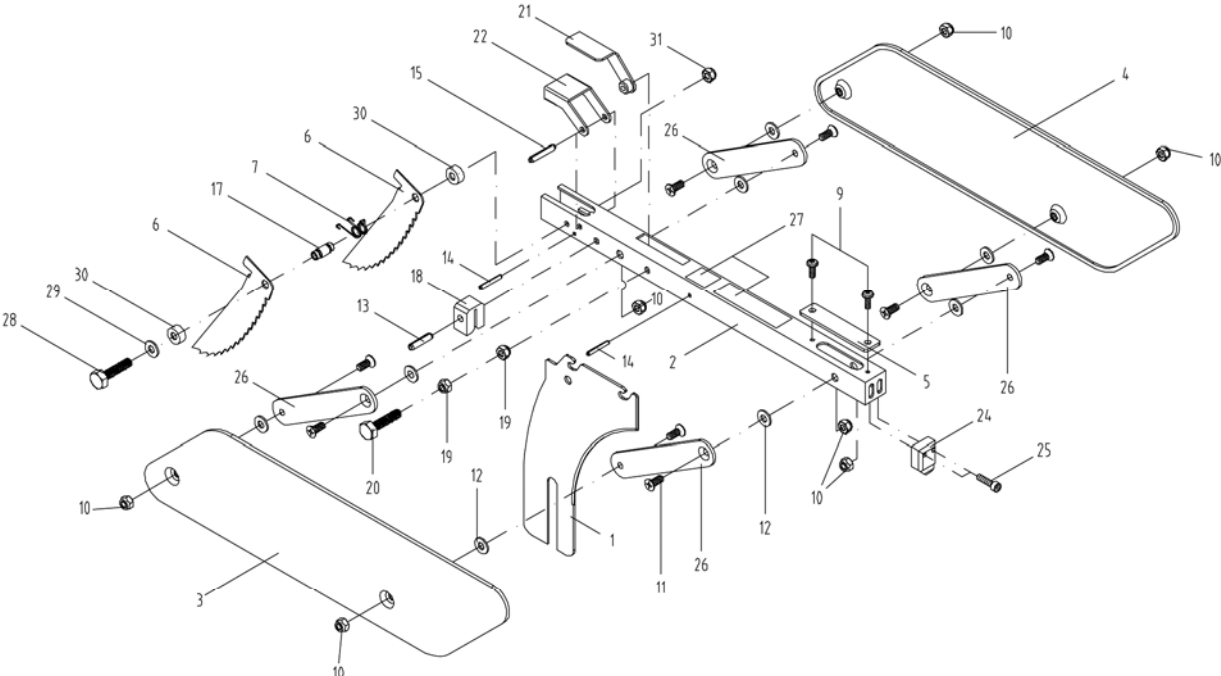

## 16.4.2 Blade Guard and Miter Gauge Assemblies – Parts List

Index No	Part No	Description	Size	Qty
	64B-BGA	Blade Guard Assembly (#1 thru #31)		1
1	64B-401	Riving Knife		1
	64B-UGA	Upper Guard Assembly (#2 thru #31)		1
2	64B-402	Support Arm		1
3	64B-403	Left side Blade Guard		1
4	64B-404	Right Side Blade Guard		1
5	64B-405	Plate		1
6	64B-406	Anti-Kickback Pawl		2
7	64B-407	Spring		1
9	TS-1533032	Phillips Pan Head Machine Screw	M5x10	2
10	TS-0640071	Nylon Lock Hex Nut	1/4"-20	8
11	TS-0813051	Flat Head Screw	1/4"-20x5/8"	8
12	TS-0680021	Flat Washer	1/4"	8
13	64B-413	Spring Pin	Ø6x30 mm	1
14	64B-414	Spring Pin	Ø3.5x28 mm	2
15	64B-415	Spring Pin	Ø5x35 mm	1
17	64B-417	Shaft		1
18	64B-418	Holding Bracket		1
19	TS-1541021	Nylon Lock Hex Nut	M6	2
20	TS-1482071	Hex Cap Screw	M6x35	1
21	64B-421	Lock Handle		1
22	64B-422	Holding Bracket		1
24	64B-424	Front Shield		1
25	TS-1502021	Socket Head Cap Screw	M5x10	2
26	64B-426	Pivot Arm		4
27	64B-427	Warning Label		1
28	TS-1481081	Hex Cap Screw	M5x35	1
29	TS-1550031	Flat Washer	M5	1
30	64B-430	Bushing		2
31	TS-1541011	Nylon Lock Hex Nut	M5	1
	1791789	Miter Gauge Assembly (#32 thru #52)		1
32	PM2000-323	Miter Gauge Body		1
33	PM2000-324	Pin		1
34	PM2000-325	Miter Bar		1
35	PM2000-326	Guide Washer		1
36	PM2000-327	Flat Head Machine Screw	M6x9	1
37	TS-0050051	Hex Cap Screw	1/4"-20x1"	2
38	PM2000-329	Socket Head Cap Screw	M5x8	2
39	PM2000-330	Support Base		1
40	PM2000-331	Knob		1
41	TS-1521011	Socket Set Screw	M4x4	1
42	PM2000-333	Locking Handle		2
43	TS-0810012	Phillips Pan Head Machine Screw	#10-24x1/4"	1
44	PM2000-335	Pointer		1
45	PM2000-336	Spring		1
46	PM2000-337	Gear Shaft		1
47	PM2000-338	Scale		1
48	PM2000-339	Rivet		2
49	PM2000-340	Handle		1
50	TS-0680031	Flat Washer	5/16"	1
51	PM2000-342	Fence		1
52	PM2000-343	Socket Set Screw	M8x6	2



# 17.0 Electrical Connections

## 17.1 Connections for 115 volt (64B Table Saw)

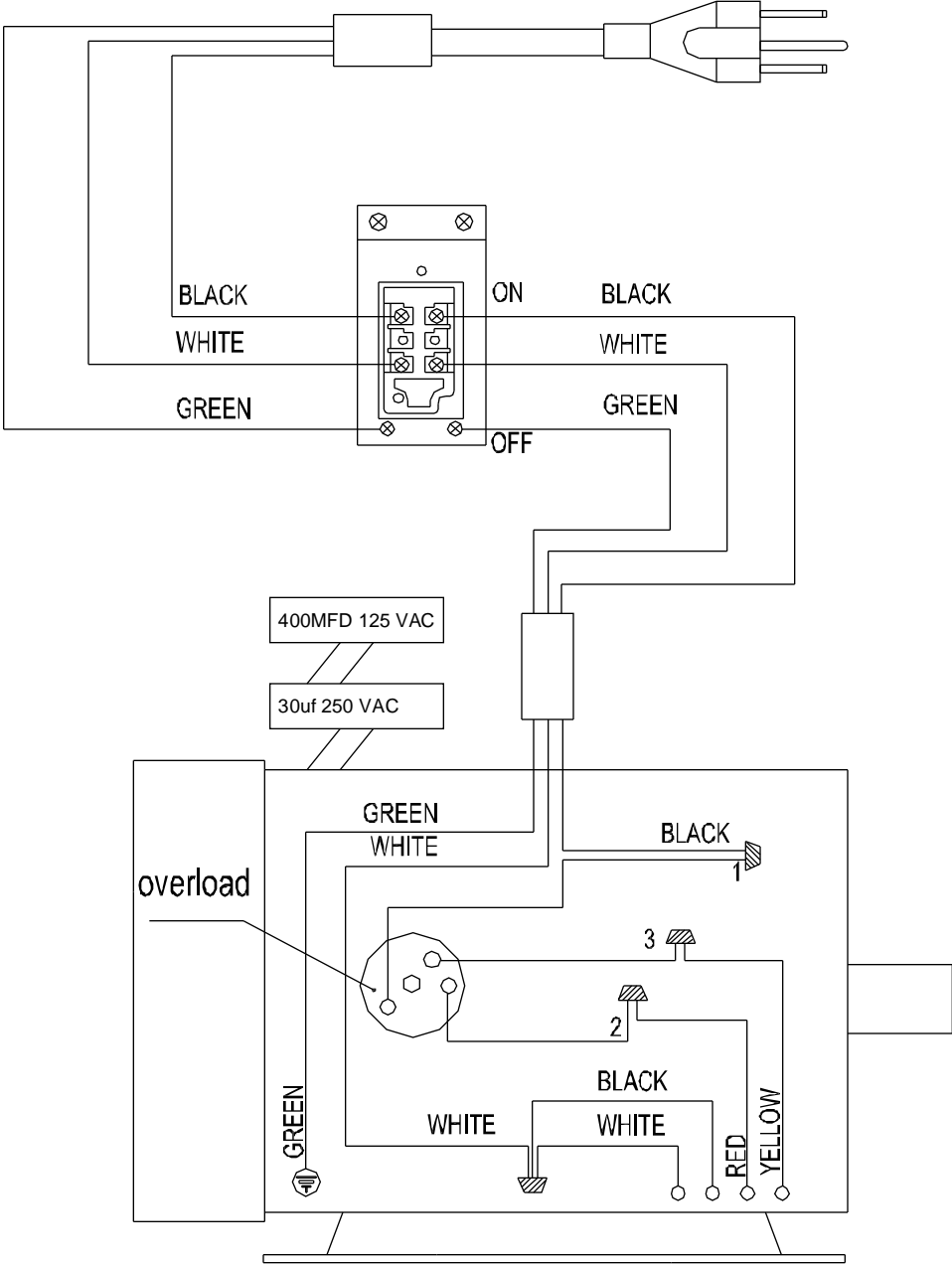

**115V**

17.2 Connections for 230 volt (64B Table Saw)

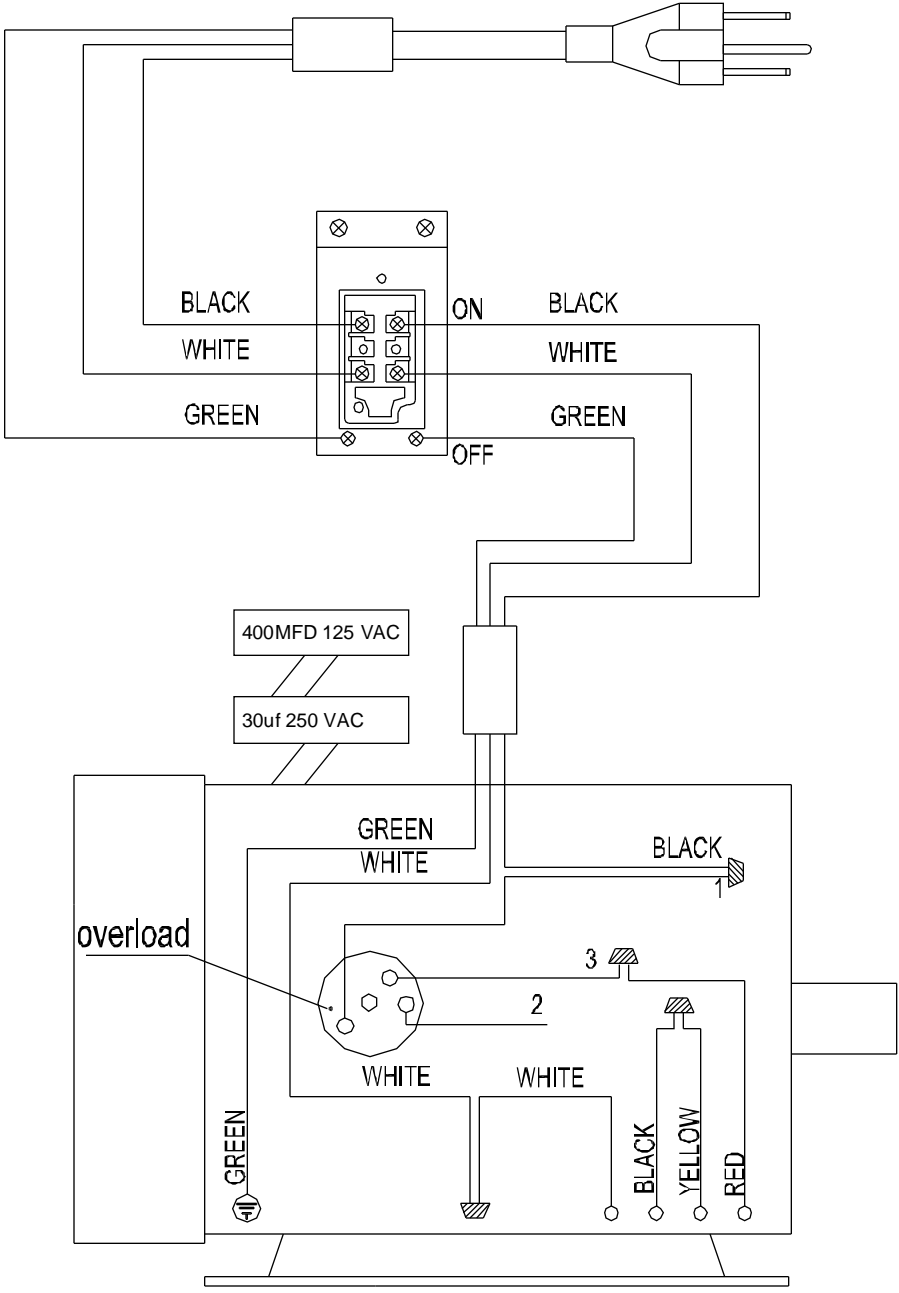

230V