

# Replacement Parts

Replacement Parts are listed on the following pages. To order parts or reach our service department, call 1-800-274-6848, Monday through Friday (see our website for business hours, [www.powermatic.com](http://www.powermatic.com)). Having the Model Number and Serial Number of your machine available when you call will allow us to serve you quickly and accurately.

## Breakdown for PM1300TX Dust Collector (Base Machine)

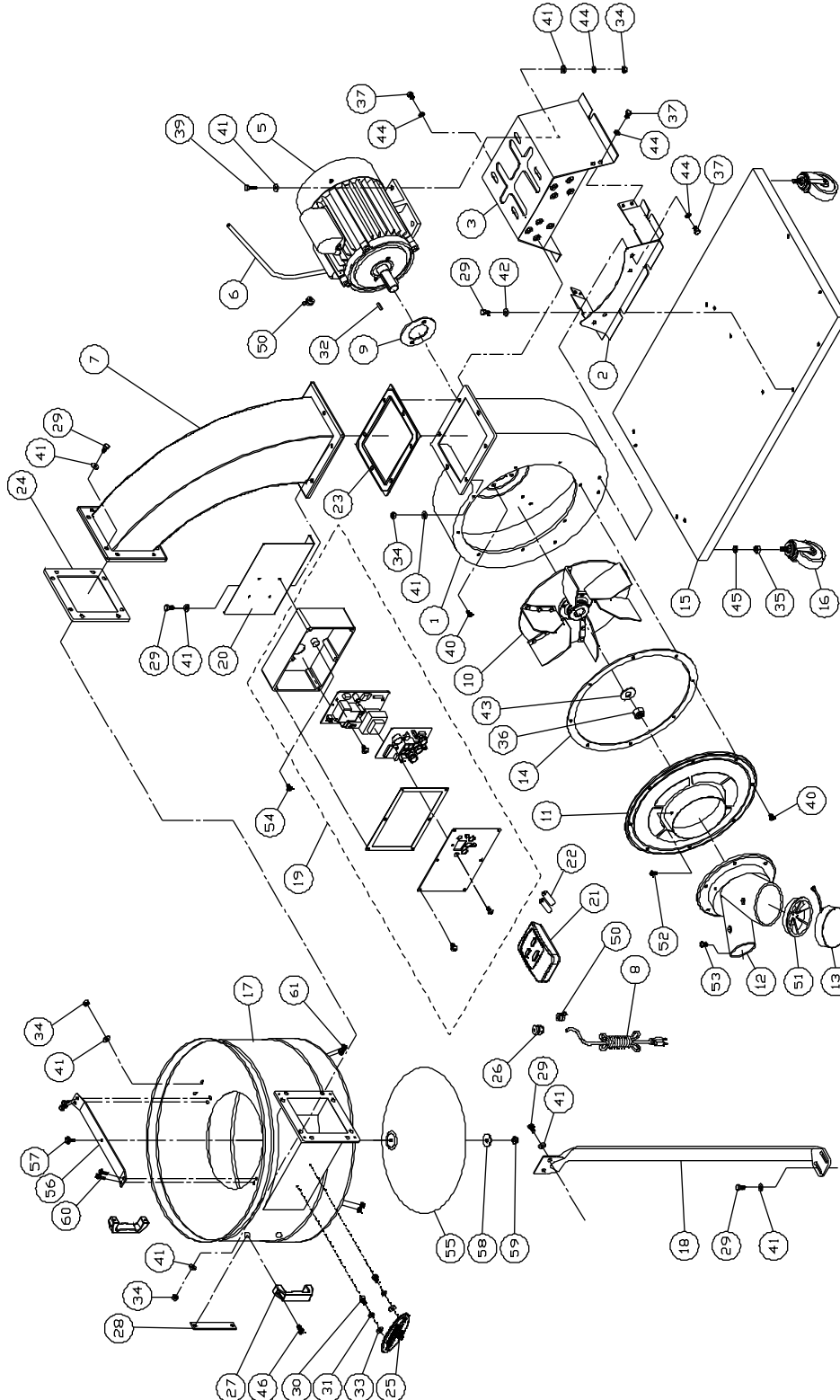

## Parts List for PM1300TX Dust Collector (Base Machine)

Index No.	Part No.	Description	Size	Qty
1	PM1300-101	Impeller Housing		1
2	PM1300-102	Housing Bracket		1
3	PM1300-103	Motor Bracket		1
5	PM1300-105	Motor	1-3/4HP, 115/230V, 1Ph	1
	PM1300-105MF	Motor Fan (not shown)		1
	PM1300-105MFC	Motor Fan Cover (not shown)		1
	PM1300-105SC2	Starting Capacitor (not shown)	300MFD, 125VAC	1
	PM1300-105RC2	Running Capacitor (not shown)	90µF, 250VAC	1
	PM1300-105CS	Centrifugal Switch (not shown)		1
	PM1300-105RS	Reset Switch (not shown)	18A	1
6	PM1300-106	Motor Cord		1
7	PM1300-107	Connector Tube		1
8	PM1300-108	Power Cord	14AWG x 3C	1
9	420051	Motor Gasket		1
10	430006	Impeller	12"	1
11	PM1300-111	Inlet Guard		1
12	PM1300-112	Inlet Port	2 @ 4"	1
13	420203	Inlet Cap		2
14	430034	Rubber Gasket		1
15	PM1300-115	Base		1
16	402036	Caster		4
17	PM1300-117	Housing		1
18	PM1900-122	Support Bar		1
19	PM1300-119	Remote Control Switch Assembly	115/230V	1
19-1	DCRC-108	Switch Box		1
19-2	DCRC-105	Digital Switch		1
19-3	DCRC-106	Circuit Board		1
19-4	DCRC-104	Seal		1
19-5	DCRC-103	Switch Plate		1
19-6	PM1900-108-6	Pan Head Screw	M5x8	4
19-7	DCRC-102	Screw		3
19-8	ST039304	Tapping Screw	M3.5x12	6
19-9	DCRC-111	Tapping Screw	M3.5x10	1
	PM1900-108-10	Display Label (not shown)		1
20	PM1900-107	Mount Plate		1
21	PM1900-129	Remote Control		1
	PM1900-129-1	Remote Control Label (not shown)		1
22		Battery ( <i>local purchase</i> )	AAA	2
23	430035	Rubber Gasket		1
24	430036	Rubber Gasket		1
25	PWBS14-254SN	POWERMATIC Nameplate, Small		1
26	31A-208-2	Strain Relief	PGA13.5	2
27	PM1900-127	Handle		2
28	PM1900-128	Fastening Plate		2
29	TS-1490031	Hex Cap Screw	M8x20	24
30	6714154	Hex Cap Screw	1/4-20 x 3/8	2
31	TS-2361061	Lock Washer	M6	2
32	KS050525	Key	5x5x25	1
33	TS-1550041	Flat Washer	M6	2
34	TS-1540061	Hex Nut	M8	20
35	TS-0561031	Hex Nut	3/8-16	4
36	TS-0561072	Hex Nut	5/8-18UNF	1
37	TS-1490011	Hex Cap Screw	M8x12	11
39	TS-1490041	Hex Cap Screw	M8x25	4
40	SF069300	Pan Head Flange Screw	M6x12	10
41	TS-1550061	Flat Washer	M8	42
42	TS-1550071	Flat Washer	M10	6

43	TS-155010	Flat Washer	M16	1
44	TS-2361018	Lock Washer	M8	15
45	TS-2361101	Lock Washer	M10	4
46	TS-1504021	Socket Head Cap Screw	M8x12	4
50	998621	Strain Relief		2
51	PM1300-151	Inlet Guard		2
52	990855	Pan Head Flange Screw	3/16"x1/2"	1
53	DCRC-111	Tapping Screw	M3.5x10	4
55	PM1300-155	Cone		1
56	DC1100-47-1	Support Bracket		1
57	TS-1490021	Hex Cap Screw	M8x16	1
58	TS-1550061	Flat Washer	M8	1
59	TS-1540061	Hex Nut	M8	1
60	TS-1482021	Hex Cap Screw	M6x12	4
61	TS-231061	Hex Nut	M6	4
	PM2700-440	Wide Stripe (not shown)		per ft.
	PM2700-441	Narrow Stripe (not shown)		per ft.
	PM1300-BMHP	Base Machine Hardware Package (not shown) *		1
	DC1100-HP2	Hardware Package for Cone Assembly (index # 57 thru 61)		1

\* Base Machine Hardware Package includes index # 29, 34, 40, 41 and 42.

# Breakdown for PM1300TX Canister Filter System

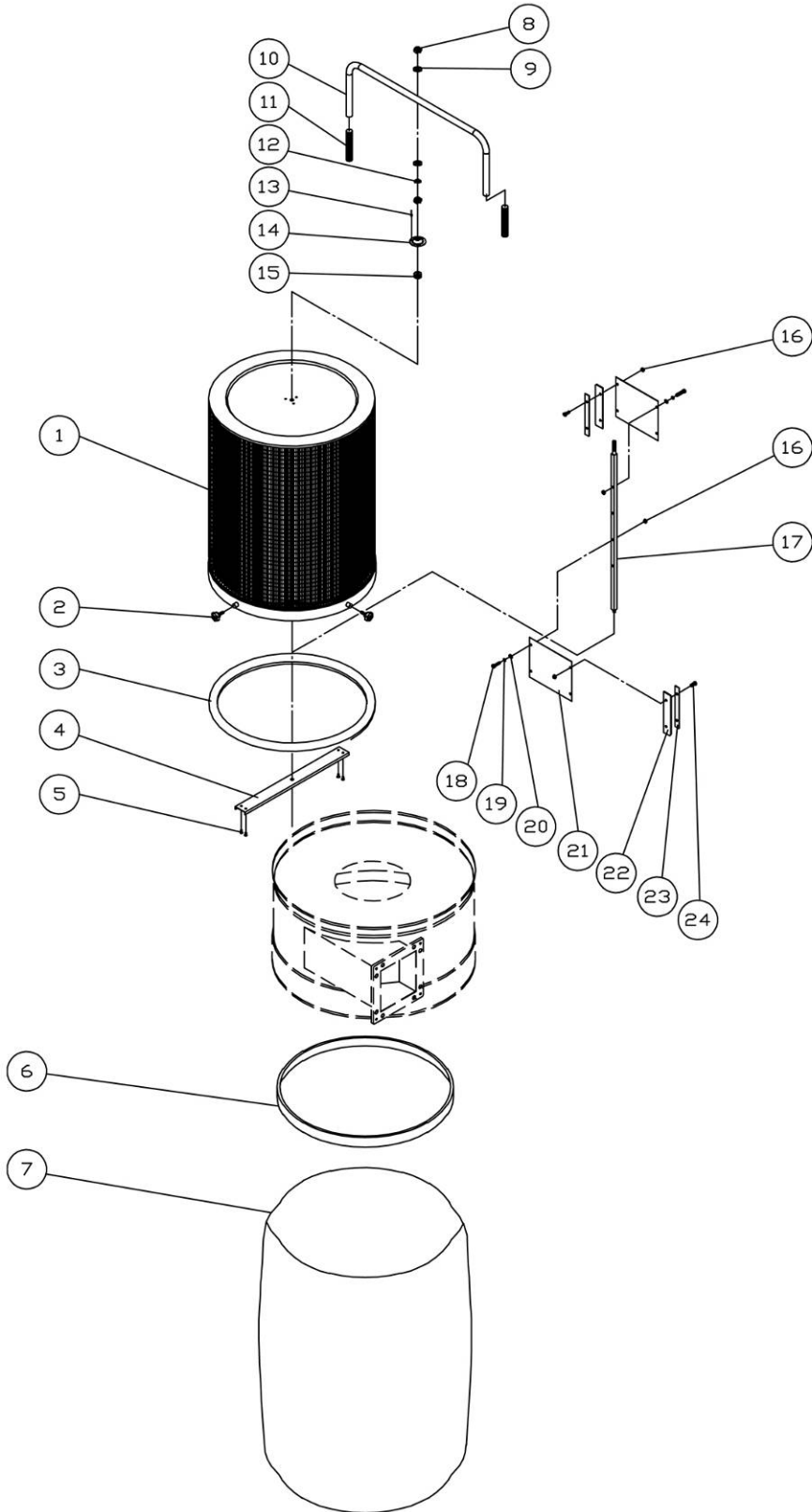

## Parts List for PM1300TX Canister Filter System

Index No.	Part No.	Description	Size	Qty
	1791086	Canister Assembly (includes #1 thru 24)		1
1	PM1900-301	Filter		1
2	PM1900-302	Knob	M6x20	4
3	331031	Pad		1
4	331009	Support		1
5	ST049200	Tapping Screw	M4x8	4
6	331038	Snap Ring		1
7	1791087	Plastic Collection Bag (Package of 5)	800x1050x0.1t mm	1
8	TS-1540071	Hex Nut	M10	2
9	TS-1550071	Flat Washer	M10	2
10	331050	Handle		1
11	331051	Soft Grip Handle		2
12	TS-2361101	Lock Washer	M10	1
13	BR000052	Rivet	5-2	3
14	331014	Bracket		1
15	150623	Rubber Mount		1
16	TS-1540041	Hex Nut	M6	8
17	331052	Shaft		1
18	TS-1482041	Hex Cap Screw	M6x20	4
19	TS-2361061	Lock Washer	M6	4
20	TS-1550041	Flat Washer	M6	4
21	331012	Scraper		2
22	331017	Plate		2
23	331015	Plate		2
24	TS-1482021	Hex Cap Screw	M6x12	4
	PM1300-PLO	Powermatic Label (not shown)	5-1/2x14 Oval	1
	PM1900-CHP	Canister Hardware Package (not shown) *		1

\*Canister Hardware Package includes index # 2, 8, 9 and 12.

# Parts List for PM1300TX Filter Bag System

Index No.	Part No.	Description	Size	Qty
.....	1791077B.....	PM1300 Collection and Filter Bag (includes #1 thru 5) .....		1
1.....	1791077F.....	Filter Bag .....	30 micron.....	1
2.....	410012.....	Retainer Strap.....		1
3.....	708699A.....	Collection Bag.....		1
4.....	402040.....	Hanger.....		1
5.....	523011.....	Hanger Bracket.....		1

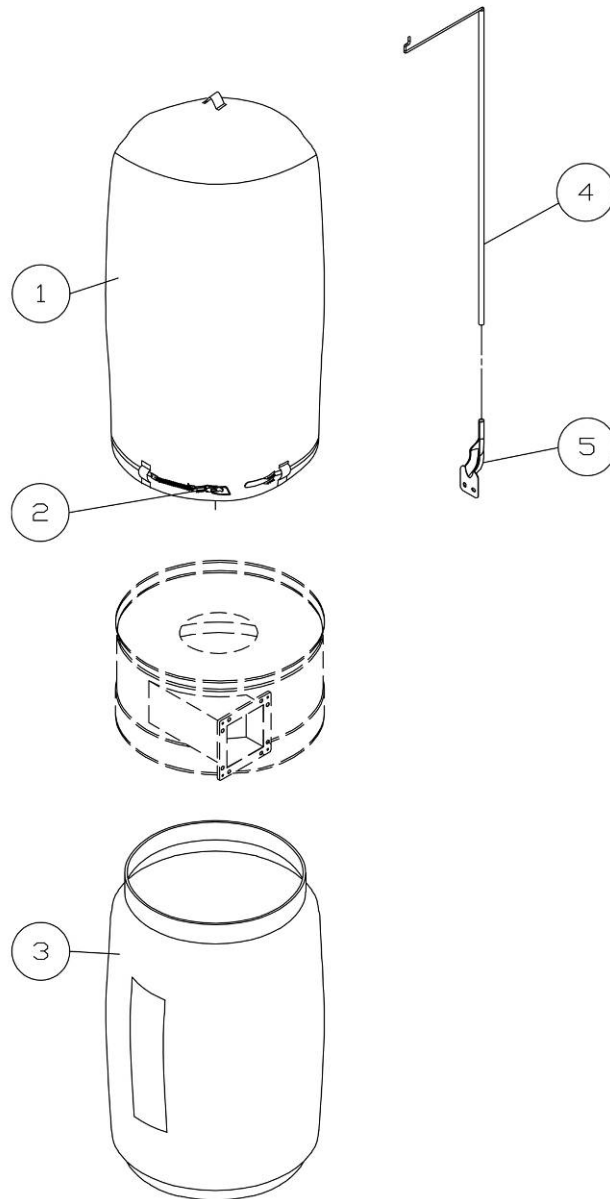

# Electrical Connections

