



SERVICE PARTS LIST

BULLETIN NO.
54-10-0132

SPECIFY CATALOG NO. AND SERIAL NO. WHEN ORDERING PARTS		REVISED BULLETIN	DATE
240V 1/2" REVERSING COMPACT DRILL		54-10-0130	Aug. '86
CATALOG NO. 1662-3	STARTING SERIAL NO. 720-1400	WIRING INSTRUCTION	
		58-01-0539	
CAT. NO.	START SER. NO.	BILINGUAL LABEL	

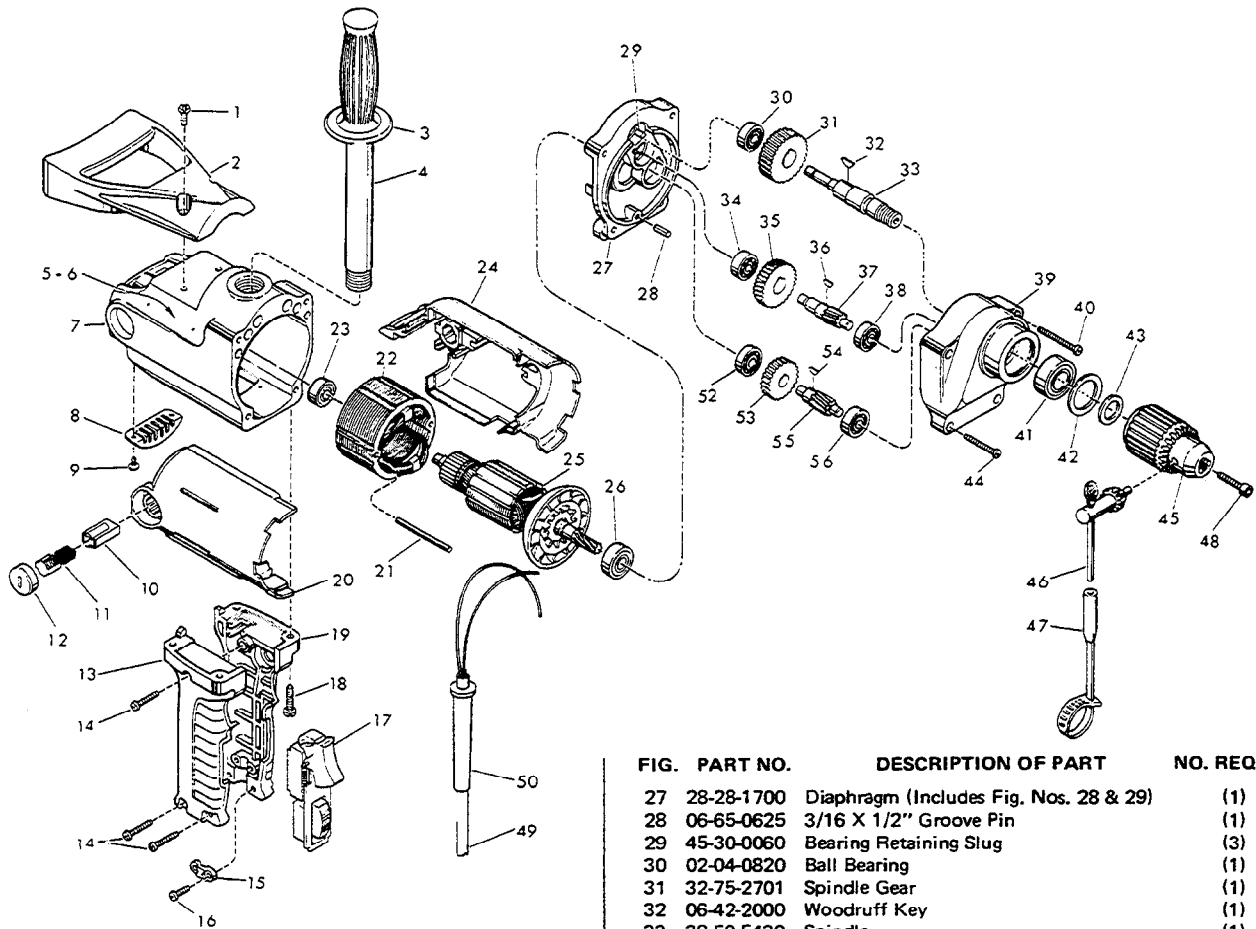

FIG.	PART NO.	DESCRIPTION OF PART	NO. REQ.
1	06-95-0460	12-24 X 3/4" Pan Hd. Taptite Sem.	(2)
2	31-44-1370	Spade Handle	(1)
3	43-62-0246	Handle Grip	(1)
4	43-62-0235	Pipe Handle	(1)
5	12-99-0390	Nameplate Blank	(1)
6	06-85-0200	6 X 1/4" Nameplate Screw	(2)
7	28-50-6270	Motor Housing	(1)
8	44-66-5510	Cover Plate	(1)
9	06-95-2100	6-32 X 1/4" Pan Hd. Taptite Sem.	(2)
10	22-20-0660	Brush Tube	(2)
11	22-18-0680	Carbon Brush Assembly	(2)
12	23-44-0180	Brush Retaining Screw	(2)
13	31-44-1440	Right Hand Handle Half	(1)
14	06-82-7326	8-16 X 1" Plastite Screw	(3)
15	31-17-0155	Cord Clamp	(1)
16	06-95-0216	8-16 X 5/8" Plastite Screw	(2)
★17	23-66-1420	On-Off Reversing Switch	(1)
18	06-95-0460	12-24 X 3/4" Pan Hd. Taptite Sem.	(4)
19	31-44-1445	Left Hand Handle Half	(1)
20	23-16-1275	Motor Insulator - Right Half	(1)
21	06-65-1230	Grooved Pin	(2)
★22	18-56-0062	120V Field (Includes Fig. No. 21)	(1)
23	02-04-0847	Ball Bearing	(1)
24	23-16-1276	Motor Insulator - Left Half	(1)
25	16-56-0060	120V Armature (Includes 22-84-0660 Fan)	(1)
26	02-04-1040	Ball Bearing	(1)

FIG.	PART NO.	DESCRIPTION OF PART	NO. REQ.
27	28-28-1700	Diaphragm (Includes Fig. Nos. 28 & 29)	(1)
28	06-65-0625	3/16 X 1/2" Groove Pin	(1)
29	45-30-0060	Bearing Retaining Slug	(3)
30	02-04-0820	Ball Bearing	(1)
31	32-75-2701	Spindle Gear	(1)
32	06-42-2000	Woodruff Key	(1)
33	38-50-5430	Spindle	(1)
34	02-04-0820	Ball Bearing	(1)
35	32-44-1161	Intermediate Gear	(1)
36	06-42-0800	Woodruff Key	(1)
37	36-66-2252	Intermediate Shaft	(1)
38	02-04-0820	Ball Bearing	(1)
39	28-14-1715	Gear Case Assy. (See Note)	(1)
40	06-95-1650	10-24 X 1-7/16" Fil. Hd. Taptite Sem.	(2)
41	02-04-1567	Ball Bearing	(1)
42	34-80-2500	Retaining Ring	(1)
43	45-88-0325	Chuck Washer	(1)
44	06-95-1625	10-24 X 1-3/16" Fil. Hd. Taptite Sem.	(2)
45	48-66-1380	1/2" Rev. Chuck (Incl. Fig. No. 46)	(1)
46	48-66-3280	Chuck Key	(1)
47	48-66-4040	Key Holder	(1)
48	06-75-3150	1/4-20 X 1" Skt. Hd. Cap Screw - L.H. Thread	(1)
49	22-64-2230	Cord Set	(1)
50	44-76-0150	Cord Protector	(1)
51	10-98-5230	Caution Label (Not Shown)	(1)
52	02-04-0820	Ball Bearing	(1)
53	32-42-1221	Intermediate Gear	(1)
54	06-42-0800	Woodruff Key	(1)
55	36-66-2201	Intermediate Shaft	(1)
56	02-04-0820	Ball Bearing	(1)

NOTE:
LUBRICATION
5-1/2 Oz. Type A

MILWAUKEE ELECTRIC TOOL CORPORATION
13135 W. LISBON RD., BROOKFIELD, WIS. 53005