

150E Chain Saw UT-10452-A 10452-A-UT 150E Chain Saw UT-10452-A 150E Chain Saw - Carburetor -
HDC-54

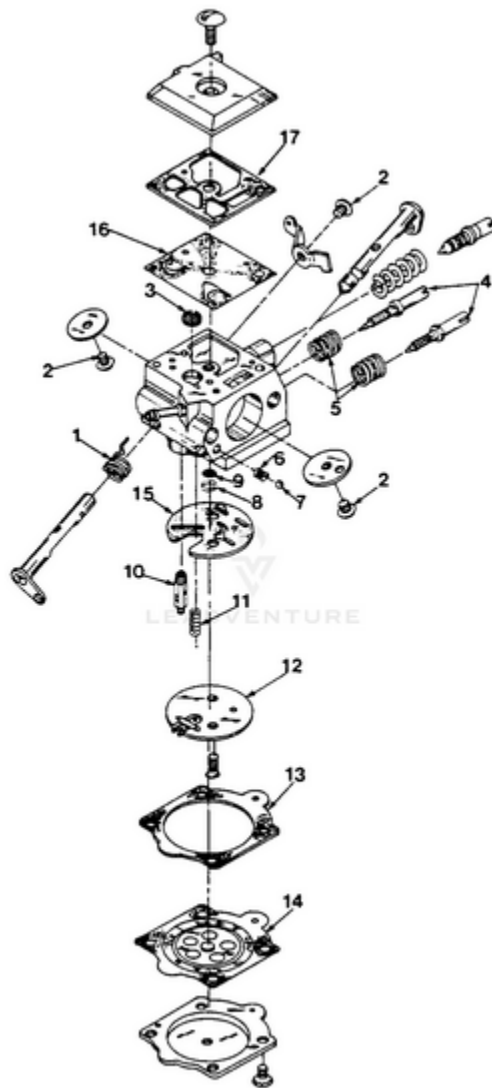

Rendered by Leadventure, Inc.

Ref #	Part #	Description	Qty
1	93200B	Repair Kit	
2	93200B	Repair Kit	
3	93200B	Repair Kit	
4	93200B	Repair Kit	
5	93200B	Repair Kit	
6	93200B	Repair Kit	
7	93200B	Repair Kit	
8	93200B	Repair Kit	
9	93200B	Repair Kit	
10	93200B	Repair Kit	
11	93200B	Repair Kit	
12	93200B	Repair Kit	
13	93200B	Repair Kit	
	94701	GASKET/Diaphragm Kit	
14	93200B	Repair Kit	
	94701	GASKET/Diaphragm Kit	
15	93200B	Repair Kit	
	94701	GASKET/Diaphragm Kit	
16	93200B	Repair Kit	
	94701	GASKET/Diaphragm Kit	
17	93200B	Repair Kit	
	94701	GASKET/Diaphragm Kit	
	65386	Repair Kit- Check Valve	

150E Chain Saw UT-10452-A 10452-A-UT 150E Chain Saw UT-10452-A 150E Chain Saw - Carburetor -
HK-3D

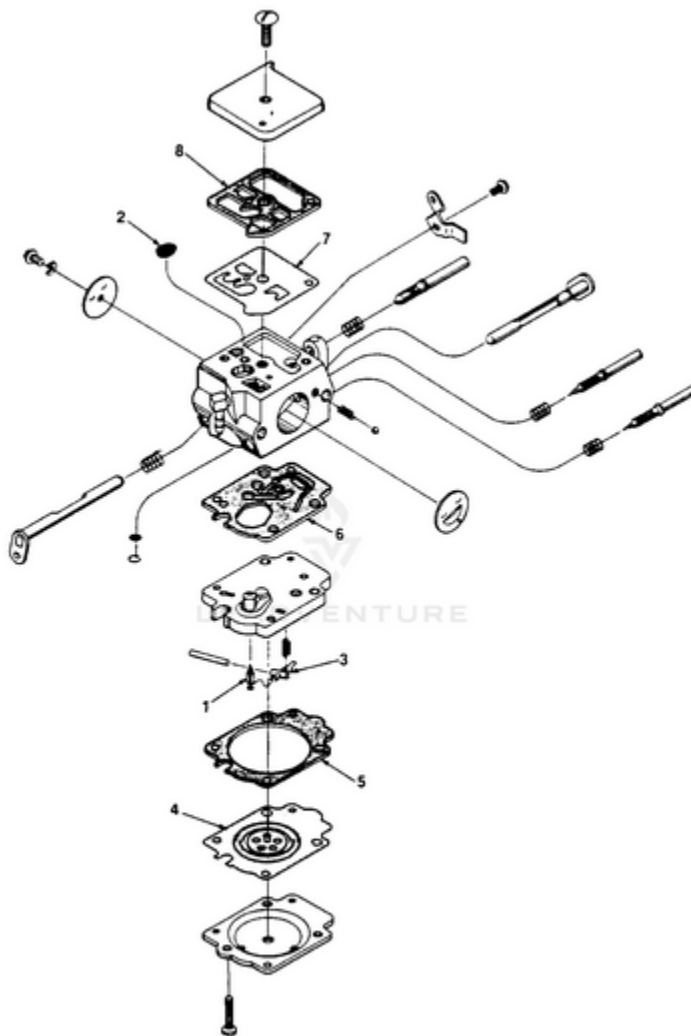

Ref #	Part #	Description	Qty
1	95697	Repair Kit	
2	95697	Repair Kit	
3	95697	Repair Kit	
4	95697	Repair Kit	
4	70094	Gasket-Diaphragm Kit	
5	95697	Repair Kit	
5	70094	Gasket-Diaphragm Kit	
6	95697	Repair Kit	
6	70094	Gasket-Diaphragm Kit	
7	95697	Repair Kit	
7	70094	Gasket-Diaphragm Kit	
8	95697	Repair Kit	
8	70094	Gasket-Diaphragm Kit	
	70109	Needle-Inlet	

150E Chain Saw UT-10452-A 10452-A-UT 150E Chain Saw UT-10452-A 150E Chain Saw - Clutch, Muffler And Flywheel

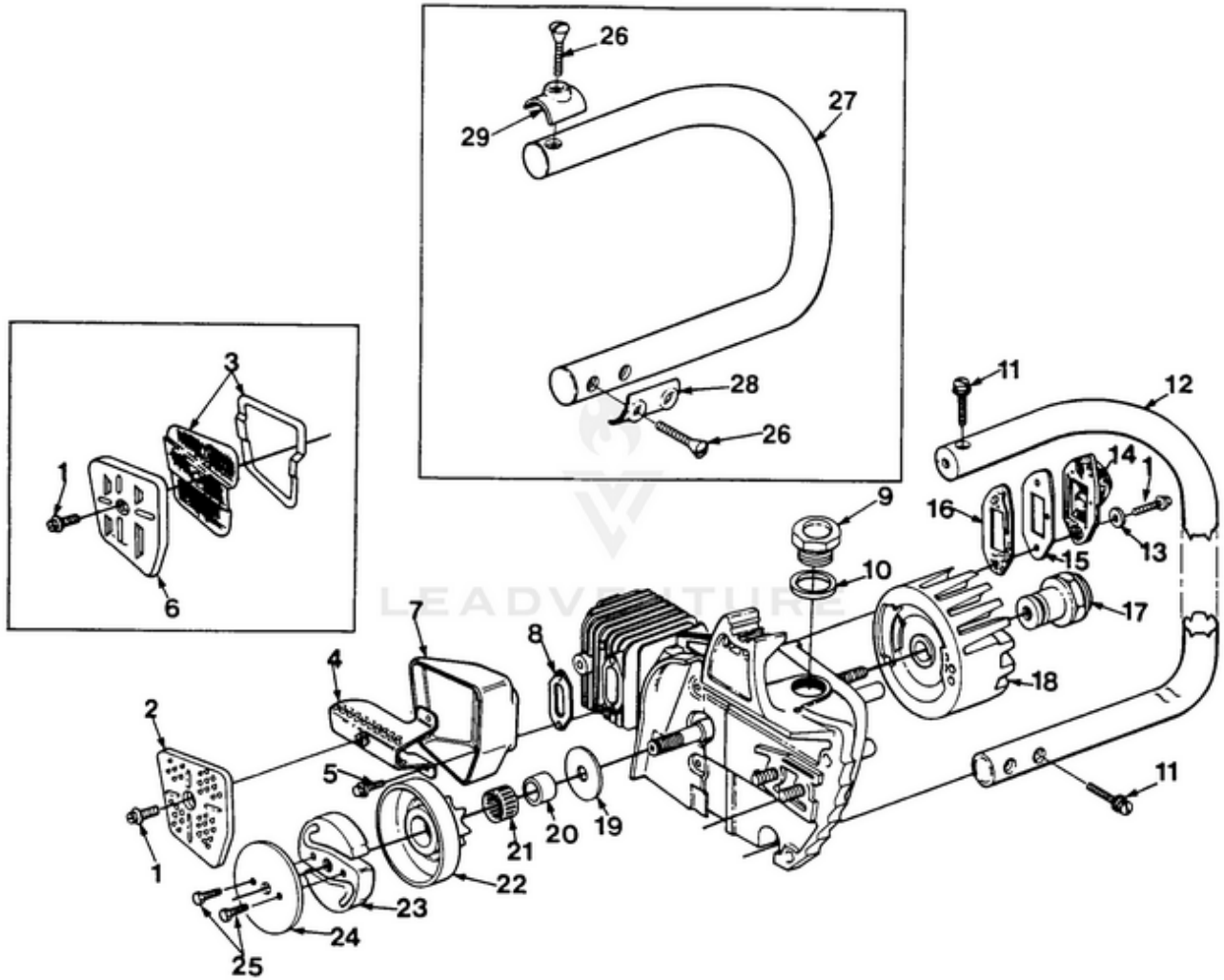

Rendered by LeadVenture, Inc.

Ref #	Part #	Description	Qty
1	80983	SCREW- Hex washer hd., 8-32 x 1/2	3
2	685961	CAP- Muffler (150 AO)	1
3	A686661B	ARRESTOR- Spark (150 AOW)	1
4	A68564	BAFFLE- Muffler	1
	A-94068	KIT- Muffler temp. (150 AOW)	1
	A686661B	Arrestor	1
5	80939	SCREW- Hex washer hd., 8-32 x 3/8	4
6	94070	CAP- Muffler (150 AOW)	1
	940711	SHIELD	1
7	685451	BODY- Muffler	1
8	68542	GASKET- Muffler	1
9	A68557	CAP- Oil filler	1
10	68533	GASKET- Oil filler cap	1
11	82218	SCREW- Oval hd., 10-24 x 1 1/8	3
12	A709041	HANDLE BAR	1
13	84103	WASHER- Flat 7/16 x 3/16 x 1/16	2
14	A685202	MANIFOLD- Intake	1
15	68671	COVER- Pulse	1
16	68464	GASKET- Intake manifold	1
17	A68610	NUT- Rotor	1
18	68530	ROTOR (point ignition)	1
18	96891	ROTOR (Solid state)	1
19	65064	WASHER- Thrust	1
20	65746B	RACE- Inner	1
21	64124	BEARING- Needle	1
22	A95619	SPROCKET & DRUM- 7 tooth, 3/8" pitch	1
	A69953A	CLUTCH & PLATE	1
23	683627	CLUTCH "S"	1
24	69915	PLATE- Clutch	1
25	803612	SCREW- Hex hd., 10-32 x 1/2	2
26	82378	SCREW- 10-24 x 1 5/8 (150 E)	2
27	A95291	HANDLE BAR (150 E)	1

Ref #	Part #	Description	Qty
28	69301	CLAMP- Handle bar (lower)	1
29	69302	CLAMP- Handle bar (upper)	1

150E Chain Saw UT-10452-A 10452-A-UT 150E Chain Saw UT-10452-A 150E Chain Saw - Engine Internals

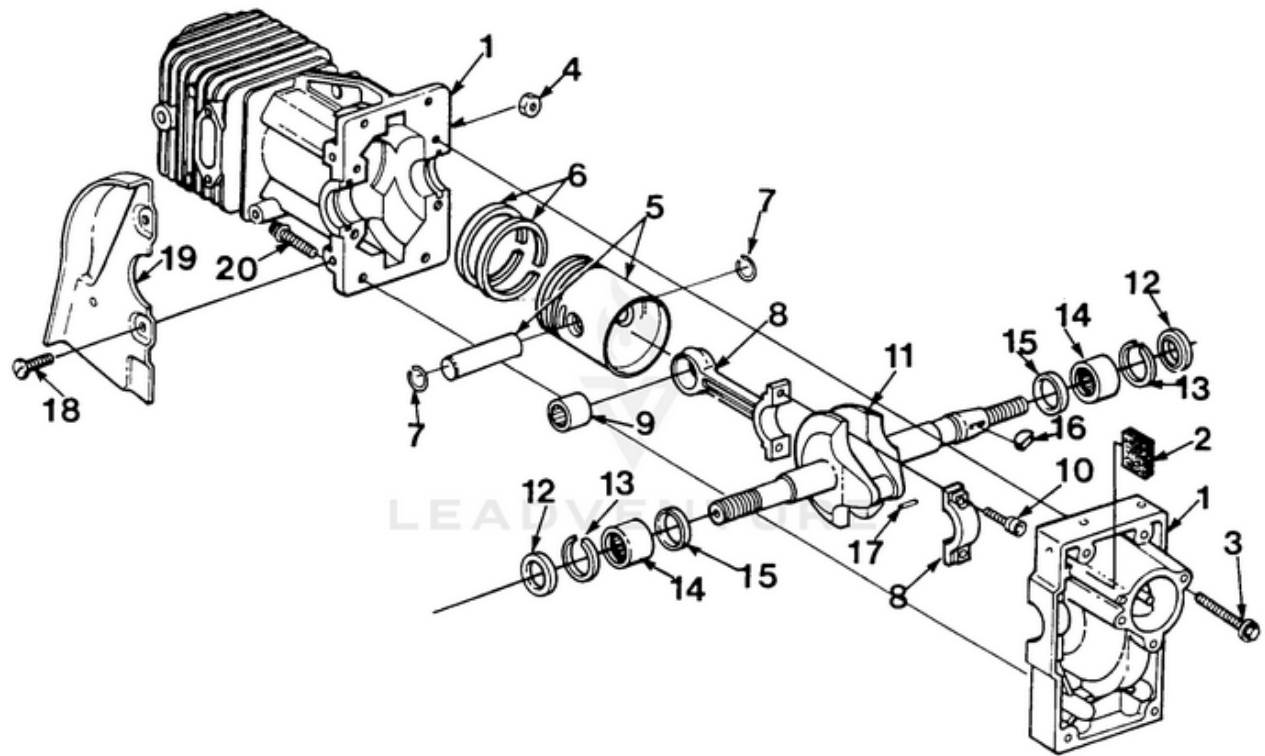

Rendered by LeadVenture, Inc.

Ref #	Part #	Description	Qty
1	A68643D	CRANKCASE & CYLINDER	1
2	68990A	COVER- Vent	1
3	88044	SCREW- Hex washer hd. 8-32 x 1	4
4	81223	NUT- Hex centerlock 8-32	4
	68623	CLAMP	1
	643091	PIN- Dowel	1
	80571	SCREW- Pan washer hd. 6-32 x 3/8	2
5	A68642	PISTON & PIN	1
6	68508	PISTON- Ring	2
7	64813	RING- Piston retaining	2
8	A68518	ROD- Connecting	1
9	68512	BEARING- Needle	1
10	69919	SCREW- Soc. hd., 8-32 x 1/2	2
11	685071	CRANKSHAFT	1
12	94638	SEAL	2
13	68514	RING- Retaining	2
14	12530	BEARING- Roller	2
15	68509A	BEARING- Thrust	2
16	65126	KEY- Woodruff	1
17	A68511	ROLLER- Needle (set of 18)	1
18	95922	SCREW- Pan taptite 8-32 x 5/16	3
19	68596	SHIELD- Sawdust	1
20	82248	SCREW- Hex hd. 8-32 x 3/4	4

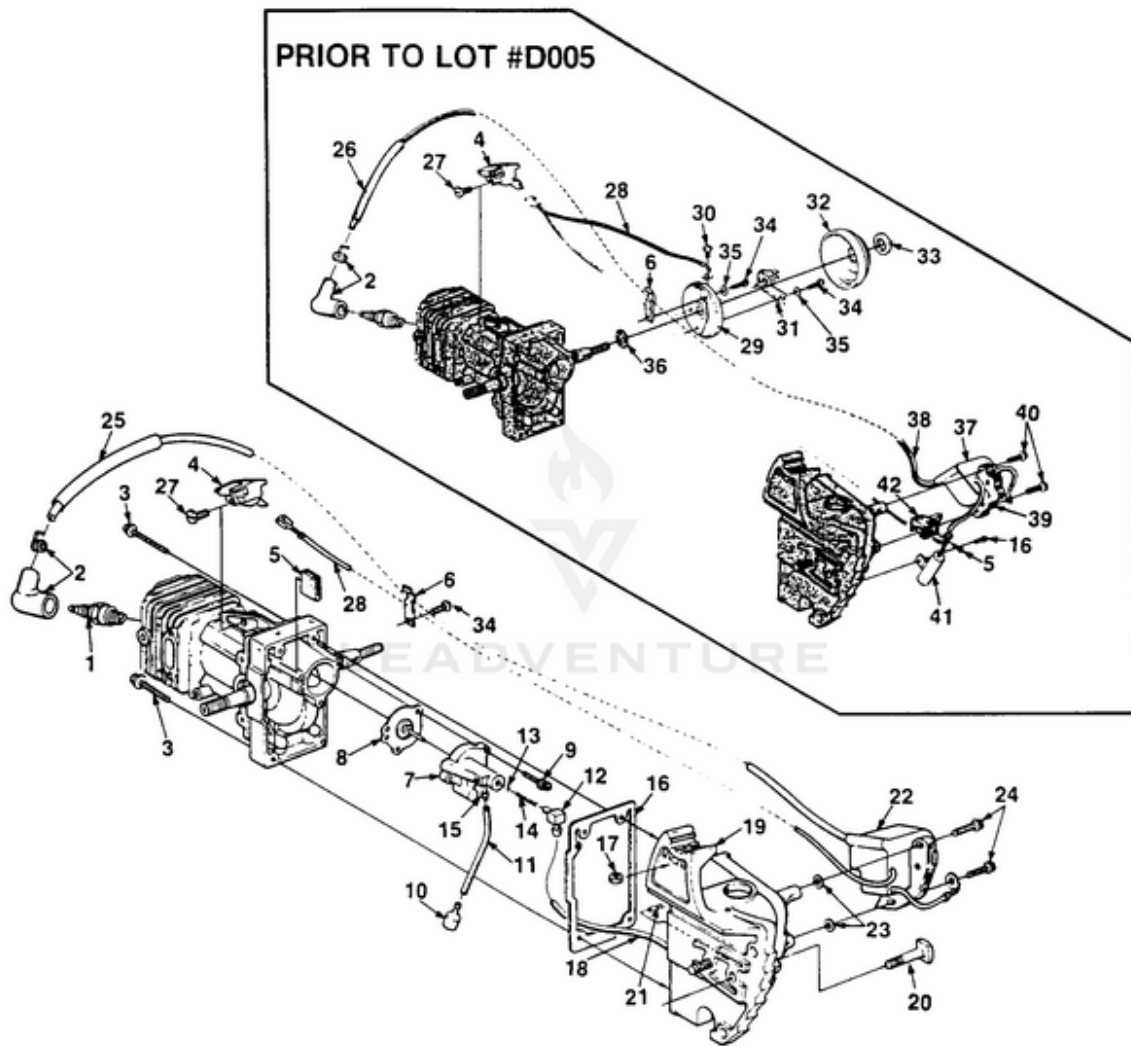

Rendered by LeadVenture, Inc.

Ref #	Part #	Description	Qty
1	68616S	SPARK PLUG	1
2	A33055	TERMINAL HIGH TENS(P TBO	1
3	88045	SCREW- Hex washer hd. 8-32 x 1.25	4
4	A69341	BUSHING & TERMINAL	1
5	68990A	COVER- Vent	1
6	68623	CLAMP- High tension lead	1
7	A70974A	PUMP- Automatic oil	1
8	A68583B	PLUNGER- Oil pump	1
9	82291	SCREW- 8-32 x .625	2
10	A68593	FILTER- Oil	1
11	7030909	LINE- Oil pick-up 2 1/4"	1
12	70204	FITTING- Tube	1
13	60051	BALL- Check friction	1
14	68570	SPRING- Choke valve	1
15	94619	FITTING- Tube	1
16	68589C	GASKET- Oil tank	1
17	81208	NUT- Hex centerlock 10-24	1
18	9311219	RUBBER- Tubing 4 3/4	1
19	A937431A	TANK- Oil	1
20	58753	BOLT- Guide bar	2
21	70972	FITTING- Tube	1
22	A97026	KIT- Ignition conversion	1
23	84101	WASHER- Flat	2
24	82248	SCREW- Mach	2
25	96907	SLEEVE- Insulating	1
26	68625	SLEEVE- Wire (fiberglass)	1
27	82256	SCREW- Pan hd., plastite (6 x 1/4)	2
28	A93626	LEAD- Stop switch	1
29	A69533A	BOX- Breaker	1
30	82256	SCREW- Plastite #6 x 1/4	1
31	A94631	POINTS- Breaker	1
32	A94231	COVER- Breaker box	1
33	68618A	SEAL- Breaker box cover	1
34	80571	SCREW- Pan washer hd., 6-32 x 3/8	2
35	84025	WASHER- Flat #8	2
36	93849	SEAL	1
37	A68649A	COIL- Ignition	1
38	68629	LEAD- Hi-tension	1
39	A68648	CORE	1
	68257	RETAINER- Coil	1

Ref #	Part #	Description	Qty
40	82248	SCREW- Hex hd. 8-32 x 3/4	2
41	68543	CONDENSER	1
42	68613	BLOCK- Terminal	1

150E Chain Saw UT-10452-A 10452-A-UT 150E Chain Saw UT-10452-A 150E Chain Saw - Starter, Tank
And Drivecase Cover

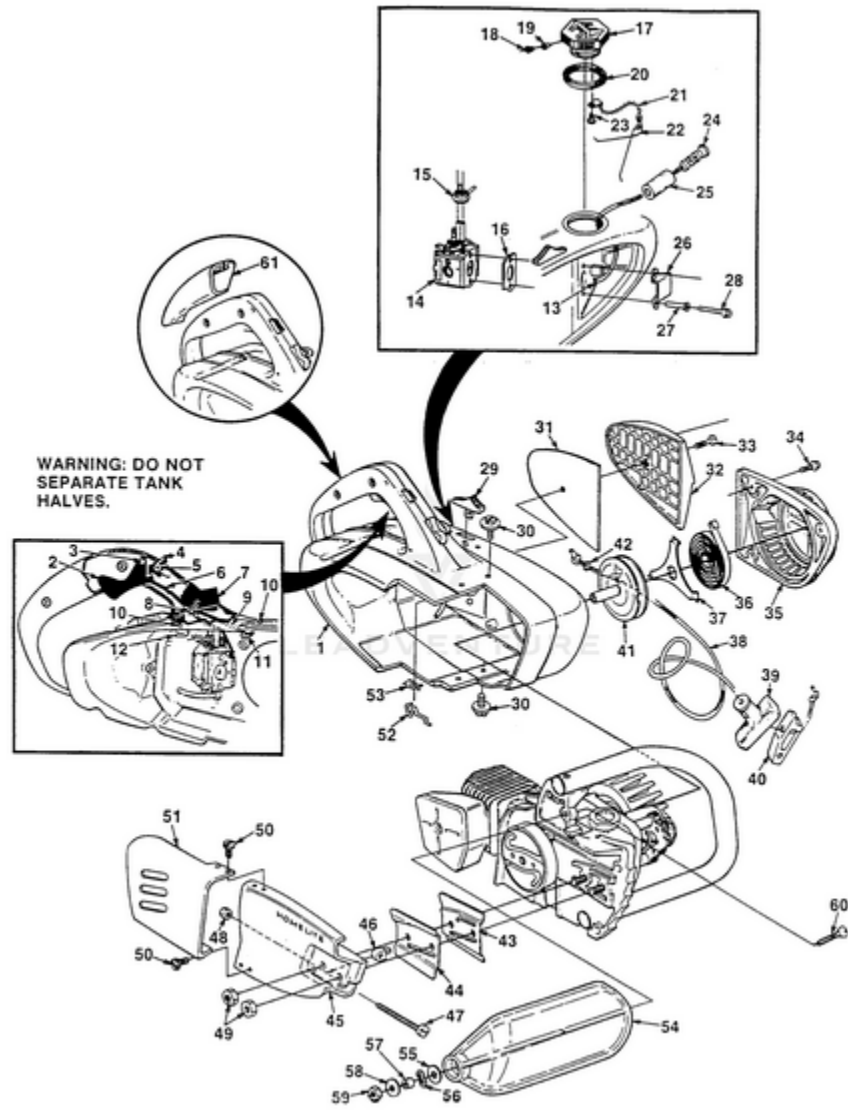

Rendered by LeadVenture, Inc.

Ref #	Part #	Description	Qty
1	A686441A	ENGINE COVER	1
1	A69549A	ENGINE COVER	1
2	A-93044	TRIGGER- Throttle	1
3	68548	PIN- Trigger	1
4	68626	SPRING- Trigger latch	1
5	68641	PIN- Grooved	1
6	68550	LINKAGE- Throttle	1
7	68580	BUTTON- Stop switch	1
8	68581	SPRING- Stop switch	1
9	68576	LINK- Grounding switch	1
10	85061	RIVET	1
11	68577	CONTACT- Grounding switch	1
12	68639	CLAMP- High tension	1
13	9477232	TUBING- Rubber (fuel) 8"	1
14	A69957B	CARBURETOR- Walbro HDC-54	1
	A95230A	CARBURETOR- Till HK-30 (alternate source)	1
15	A-70332	DETENT- Carburetor	1
16	68537	SPACER- Carburetor	1
17	A69500A	CAP- Fuel filler	1
18	69454	FILTER- Fuel cap	1
19	69451	VALVE- Check	1
20	69501	GASKET- Fuel filler cap	1
21	69502	CHAIN- Bead	1
22	69503	RETAINER	1
23	82256	SCREW- Pan hd., #6 x 1/4	1
24	A69923	USE UP06560	1
25	64083	ELEMENT- Felt filter	1
26	68534	DEFLECTOR- Air	1
27	68560	BUSHING- Flanged	1
28	82224	SCREW- Hex washer hd., 8-32 x 2	2
29	68551	BUTTON- Choke	1
30	69335A	SCREW- Sems hex hd., 10-24 x 5/8	4
31	68532	FILTER- Element air	1
32	68531A	COVER- Air filter	1
33	68535	SCREW- Cover retaining	1
34	80983	SCREW- Hex washer hd., 8-32 x 1/2	2
	A68611A	STARTER- Complete	1

Ref #	Part #	Description	Qty
35	A68523A	HOUSING- Starter	1
36	65107	SPRING- Rewind	1
37	68612	RETAINER- Rewind spring	1
38	A93876	USE UP06820	1
39	A69962B	GRIP- Starter rope	1
40	70018A	INSERT- Rope retaining	1
41	A68645A	PULLEY- Starter	1
42	93862	WASHER- Nylon	1
43	67300C	PLATE- Guide bar (inner)	1
44	67299C	PLATE- Guide bar (outer)	1
45	A686141A	COVER- Drivecase	1
46	651121	PIN- Guide bar adjusting	1
47	65175A	SCREW- Guide bar adjusting	1
48	81206	NUT- Hex centerlock, 10-32	1
49	81196	NUT- Hex 5/16-18	2
50	80939	SCREW- Pan hd., 8-32 x 3/8 (150 AOW)	2
51	940711	SHIELD MUFFLER- (150 AOW)	1
52	68552	ROD- Choke	1
53	68584A	SPRING- Choke	1
54	A-95088	HANDGUARD	1
55	95935	WASHER	1
56	96757	WASHER	1
57	95937	SPACER	1
58	840651	WASHER	1
59	81225	NUT- Hex (12-24)	1
60	80945	SCREW- Flat head	1
61	69303	COVER- Right hand	1

ACCESSORIES

GREASE	17193
KIT- Spike bumper	A-68655
Includes:	
SCREW (2)	80648
NUT (2)	81206
REEL- 250 Ft. starter rope #4	68848
TUBING- Rubber 10 ft.	70309-99
TUBING- Rubber 10 ft.	94772-99
TUBING- Rubber 10 ft.	93112-99
PAINT- Red- 12oz.	23475
CASE- Carrying	94216
DECALS- Set of four	A-69048-A

TOOLS

TOOL- Check valve	24972
GAUGE- (.015 pink plastic feeler)	22486
LOCTITE	23488-C
PLUG- Needle bearing installation	23756
PULLER- Magneto rotor	A-24544
Includes:	
SCREW- Hex 10-32 x 1 3/8 (4)	82162
WASHER- Flat #10 (4)	84003-1
NUT- Hex centerlock 10-32 (4)	81206
SCREWDRIVER	24541
SHIM (.012 black plastic) Magneto air gap	24306
SPACER- Plug	24548
WRENCH- Spanner (clutch)	A-93791
Includes:	
PIN- Clutch spanner (2)	23717-A
WRENCH- Socket	68651

Rendered by LeadVenture, Inc.

Ref #	Part #	Description	Qty
17193	17193	GREASE	
A-68655	A-68655	KIT- Spike bumper	
80648	80648	SCREW (2)	
81206	81206	NUT (2)	
68848	68848	REEL- 250 Ft. starter rope #4	
7030999	7030999	TUBING- Rubber 10 ft.	
9477299	9477299	TUBING- Rubber 10 ft.	
9311299	9311299	TUBING- Rubber 10 ft.	
23475	23475	PAINT- Red- 12 oz.	
94216	94216	CASE- Carrying	
A69048A	A69048A	DECALS- Set of four	
24972	24972	TOOL- Check valve	
22486	22486	GAUGE- (.015 pink plastic feeler)	
23488C	23488C	LOCTITE	
23756	23756	PLUG- Needle bearing installation	
A-24544	A24544	USE A24544A	
82162	82162	SCREW- Hex 10-32 x 1 3/8 (4)	
840031	840031	WASHER- Flat #10 (4)	
81206	81206	NUT- Hex centerlock 10-32 (4)	
24541	24541	SCREWDRIVER	
24306	24306	SHIM (.012 black plastic) Magneto air gap	
24548	24548	SPACER- Plug	
A-93791	A93791	CLUTCH TOOL	
23717A	23717A	PIN- Clutch spanner (2)	
68651	68651	WRENCH- Socket	