



# SERVICE PARTS LIST

**BUL. 54-08-2064**

## 1/2" REVERSING DRILL

REVISED BUL. 54-08-2063      DATE Aug '78

**Catalog No. 1201-1**

Starting Serial No. **495-26000**

WIRING INSTRUCTIONS **58-01-0243**

Specify Catalog and Serial No. when ordering parts

**350 R.P.M. FOR CAT. NO. 1201-3 (240V) TOOL USE:**

- 18-36-0200 FIELD
- 16-36-0305 ARMATURE
- 22-16-0255 CARBON BRUSH
- 22-64-4100 CORD SET

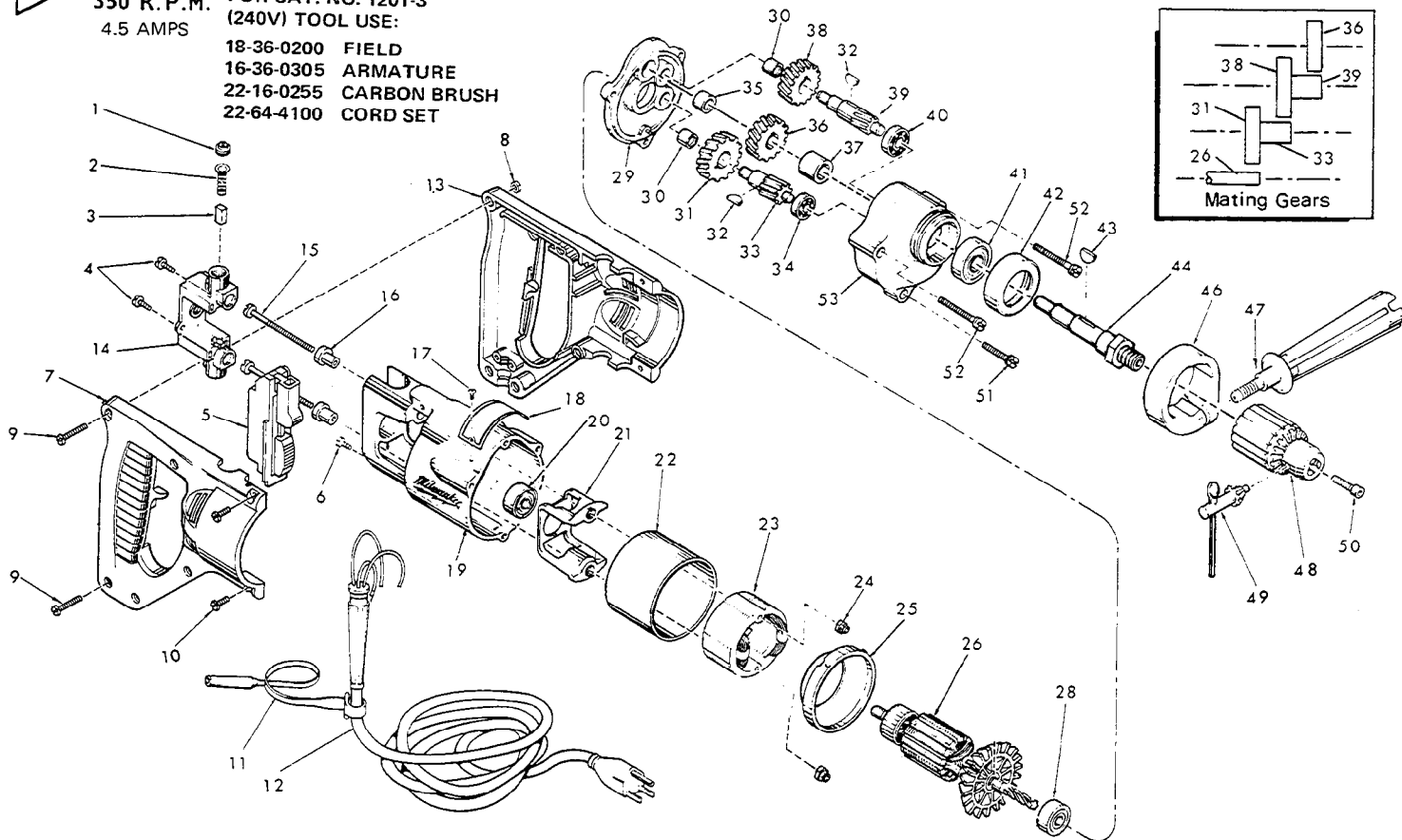

FIG.	PART NO.	DESCRIPTION OF PART	NO. REQ.	FIG.	PART NO.	DESCRIPTION OF PART	NO. REQ.
1	23-44-0120	Brush Retaining Screw	(2)	28	02-04-0940	Ball Bearing	(1)
2	23-52-0160	Brush Spring	(2)	29	28-28-0662	Diaphragm	(1)
3	22-16-0250	Carbon Brush	(2)	30	02-50-1640	Needle Bearing	(2)
4	06-81-5477	6-32x3/8 Phillips Pan Hd. Sem	(2)	31	32-40-1241	Intermediate Gear	(1)
5	23-66-1020	Switch	(1)	32	06-42-0800	Woodruff Key	(2)
6	06-81-8625	6-32x1/4 Ground Screw	(1)	33	36-66-2801	Intermediate Shaft	(1)
★ 7	31-44-0565	R.H. Half D Handle	(1)	34	02-04-0640	Ball Bearing	(1)
★ 8	06-55-0825	8-32 Hex Nut	(5)	35	02-50-2110	Needle Bearing	(1)
9	06-81-0472	8-32x1 Pan Hd. Screw	(5)	36	32-75-2641	Spindle Gear	(1)
10	06-81-0047	8-32x1/2 Pan Hd. Screw	(4)	37	45-36-0210	Spindle Gear Spacer	(1)
11	48-66-4040	Key Holder	(1)	38	32-75-2041	Spindle Gear	(1)
★ 12	22-64-0405	Cord Set	(1)	39	36-66-3951	Intermediate Shaft	(1)
★ 13	31-44-0575	L.H. Half D Handle	(1)	40	02-04-0820	Ball Bearing	(1)
★ 14	22-22-0302	Brush Holder Assembly	(1)	41	02-04-1560	Ball Bearing	(1)
15	06-81-1055	8-32x2-3/16 Field Bolt	(2)	42	42-52-0071	Bearing Cap	(1)
16	31-86-0120	Insulating Spacer	(2)	43	06-42-1600	Woodruff Key	(1)
17	06-85-0200	6x1/4 Rd. Hd. Type Z Screw	(2)	44	38-50-3651	Spindle	(1)
18	12-99-0030	Nameplate	(1)	45	49-15-0200	Side Handle Assy. (Includes Nos. 46 & 47)	(1)
19	28-50-6147	Motor Housing	(1)	46	28-82-0130	Handle Ring	(1)
20	02-04-0891	Ball Bearing	(1)	47	43-62-0550	Side Handle	(1)
21	31-55-0030	Coil Shield	(1)	48	48-66-1360	1/2" Chuck (Includes Fig. No. 49)	(1)
22	23-16-0456	Field Insulator	(1)	49	48-66-3280	Chuck Key	(1)
23	18-30-0200	120 V. Field	(1)	50	06-75-3150	1/4-20x1 L.H. Skt. Hd. Cap Screw	(1)
24	06-57-2975	8-32 Flexlock Hex Nut	(2)	51	06-81-6402	8-32x1-1/8 Fil. Hd. Sem	(1)
25	31-05-0050	Baffle	(1)	52	06-81-6707	8-32x1-7/8 Fil. Hd. Sem	(2)
26	16-30-0305	120 V. Armature	(1)	53	28-14-1261	Gear Case	(1)
				54	12-98-7081	Caution Plate (Not Shown)	(1)