



SERVICE PARTS LIST

BULLETIN NO.
54-08-1250

SPECIFY CATALOG NO. AND SERIAL NO. WHEN ORDERING PARTS		REVISED BULLETIN	DATE
CORDLESS 18 VOLT KEYLESS 1/2" D-HANDLE DRILL			Oct. '97
CATALOG NO.	1108-20 1108-21	STARTING SERIAL NO.	937A
		WIRING INSTRUCTION	58-01-0790

EXAMPLE:
Component Parts (Small #)
Are Included When Ordering
The Assembly (Large #).

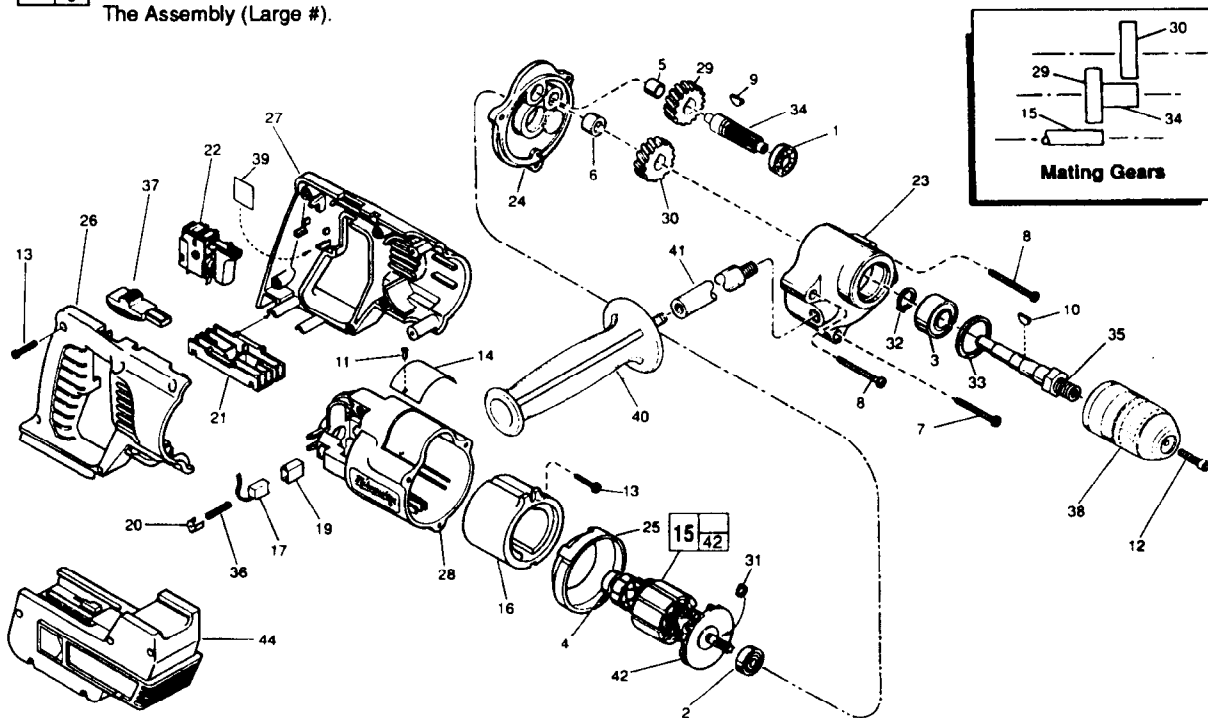

FIG.	PART NO.	DESCRIPTION OF PART	NO. REQ.	FIG.	PART NO.	DESCRIPTION OF PART	NO. REQ.
1	02-04-0725	Ball Bearing	(1)	36	40-50-8775	Brush Spring	(2)
2	02-04-0911	Ball Bearing	(1)	37	45-24-0220	3 Position Locking Slide	(1)
3	02-04-1536	Ball Bearing	(1)	38	48-66-0600	1/2" Keyless Chuck	(1)
4	02-04-5130	Ball Bearing	(1)	39	10-15-0175	Wiring Instruction Label	(1)
5	02-50-1640	Needle Bearing	(1)	40	43-62-0880	Side Handle	(1)
6	02-50-2440	Needle Bearing	(1)	41	43-62-1170	Side Handle Extension	(1)
7	05-88-5905	K50 x 41mm Pan Hd. PT T-20	(1)	42	22-84-0830	Fan Assembly	(1)
8	05-88-5927	K50 x 63mm Pan Hd. PT T-20	(2)	23-94-5890	Leadwire Assy.-Black (See 58-01-0790)	(1)	
9	06-42-0800	Woodruff Key	(1)	23-94-5895	Leadwire Assy.-White (See 58-01-0790)	(1)	
10	06-42-2000	Woodruff Key	(1)	44	48-11-2100	18 Volt Battery (Accessory)	(1)
11	06-72-1720	Nameplate Rivet	(2)	44A	31-50-1432	Battery Housing Kit (Contains 44B Thru 44G)	(1)
12	06-75-3150	1/4-20 x 1" L.H. Thread Socket Hd. Screw	(1)	44B	31-50-1421	Battery Housing-Left (Not Shown)	(1)
13	06-82-7261	6-19 x 11/16" Pan Hd. Slit. Plastite T-15	(8)	44C	31-50-1426	Battery Housing-Right (Not Shown)	(1)
14	12-99-0012	Service Nameplate	(1)	44D	31-50-1431	Battery Housing-Top (Not Shown)	(1)
15	16-01-0100	Armature	(1)	44E	10-20-7010	Power Plus Label-Right (Not Shown)	(1)
16	18-01-0055	Field	(1)	44F	10-20-7020	Power Plus Label-Left (Not Shown)	(1)
17	22-18-0975	Carbon Brush Assembly-Right	(1)	44G	12-05-1170	Nameplate Label (Not Shown)	(1)
17A	22-18-0970	Carbon Brush Assembly-Left (Not Shown)	(1)	44H	06-82-7295	9-16 x 1/2" Pan Hd. T-15 (Not Shown)	(6)
19	22-20-0860	Brush Tube	(2)	44J	44-20-0411	Battery Latch-Right (Not Shown)	(1)
20	22-32-0400	Brush Spring Clip	(2)	44K	44-20-0421	Battery Latch-Left (Not Shown)	(1)
21	22-56-0200	Connector Block	(1)	44L	40-50-8795	Latch Spring (Not Shown)	(2)
22	23-66-2350	Switch	(1)				
23	28-14-1922	Gearcase	(1)				
24	28-28-0601	Diaphragm	(1)				
25	31-05-0080	Baffle	(1)				
26	31-44-0681	Handle Half-Right	(1)				
27	31-44-0686	Handle Half-Left	(1)				
28	31-50-0961	Motor Housing	(1)				
29	32-40-1251	Intermediate Gear	(1)				
30	32-75-2011	Spindle Gear	(1)				
31	34-60-0650	External Retaining Ring	(1)				
32	34-60-1200	Retaining Ring	(1)				
33	34-80-2500	Retaining Ring	(1)				
34	36-66-2711	Intermediate Pinion	(1)				
35	38-50-5475	Spindle	(1)				

FIG. LUBRICATION:
23 3-3/4 Oz. Type "A" Grease, No. 49-08-0800.

FIG. NOTES:
17, 17A, 19 Remove Brushes And Brush Tubes To Prevent Damage When Installing Or Removing Armature From Motor Housing.
40 Apply Red Loctite To Threads Of Side Handle.