



# SERVICE PARTS LIST

**BULLETIN NO.**  
**54-08-1215**

SPECIFY CATALOG NO. AND SERIAL NO. WHEN ORDERING PARTS		REVISED BULLETIN	DATE
<b>1/2" REVERSING DRILL</b>		54-08-1214	Mar.'93
CATALOG NO.	1107-1	WIRING INSTRUCTION	
STARTING SERIAL NO.	629-133212	<b>58-01-0287</b>	

**EXAMPLE:**  
Component Parts ( Small # )  
Are Included When Ordering  
The Assembly ( Large # ).

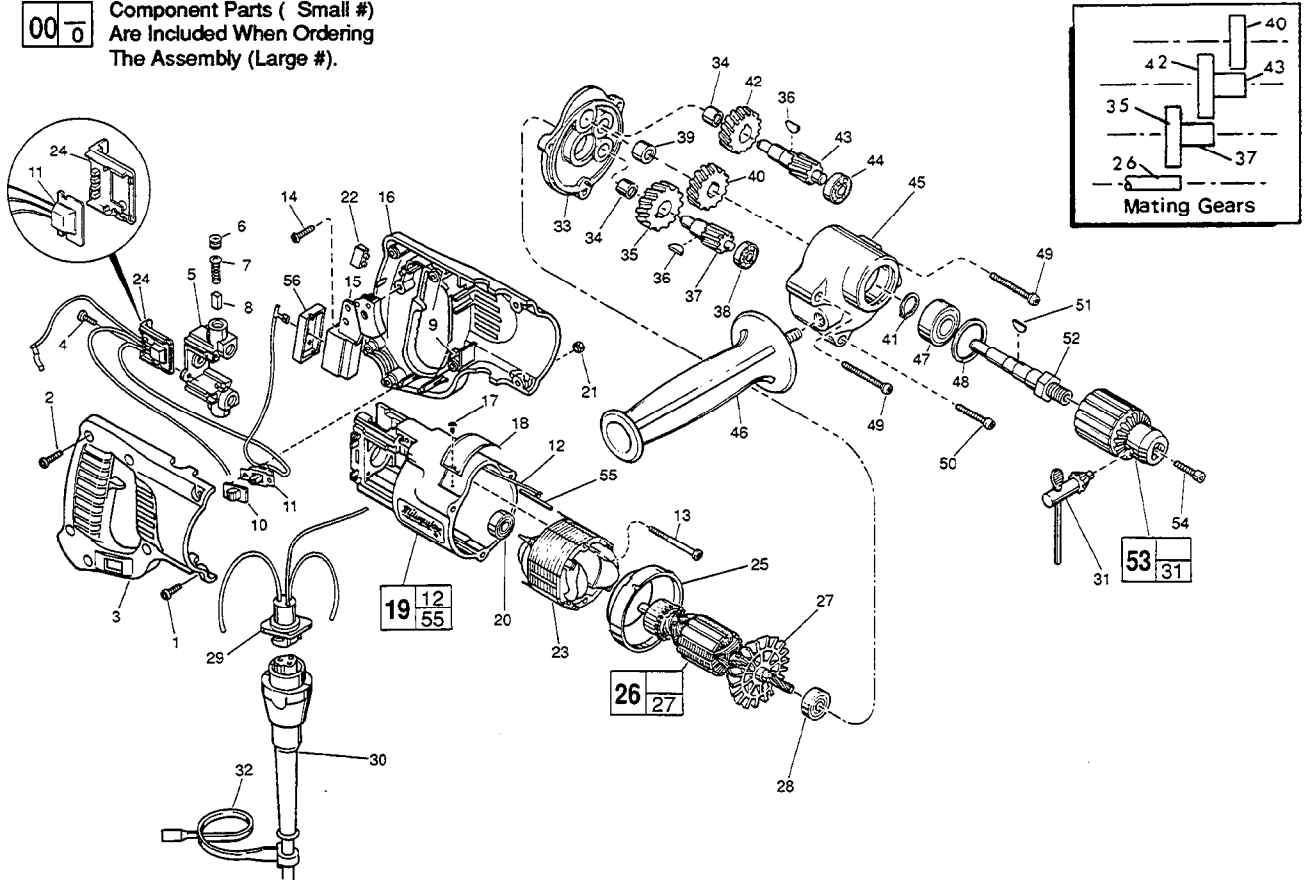

FIG.	PART NO.	DESCRIPTION OF PART	NO. REQ.
★ 1	06-82-5390	8-32x1-1/4" Tapite T-20	(2)
★ 2	06-82-7270	8-16 x 5/8" Pan Hd. Plastite T-20	(5)
★ 3	31-44-1660	Right Handle Half	(1)
★ 4	06-82-7240	6-19 x 1/2" Pan Hd. Plastite T-15	(2)
★ 5	22-22-1380	Brush Holder Assembly	(1)
6	23-44-0190	Brush Retaining Cap	(2)
7	23-52-0160	Brush Spring	(2)
8	22-16-0275	Carbon Brush	(2)
9	14-46-1001	Foam Slug Kit-10 Slugs	(2)
★ 10	31-12-0196	Switch Cap	(1)
★ 11	14-20-0357	Switch Assembly	(1)
★ 12	23-94-6100	Ground Wire Assembly	(1)
★ 13	06-82-7410	8-16 x 1-7/8" Pan Hd Slit. Plastite T-20	(2)
★ 14	06-82-7270	8-16 x 5/8" Pan Hd. Plastite T-20	(1)
★ 15	23-66-1490	On-Off Switch	(1)
16	31-44-1665	Left Handle Half	(1)
★ 17	06-85-0200	Nameplate Screw	(2)
★ 18	12-99-0515	Nameplate Blank	(1)
19	31-50-0846	Motor Housing Assembly	(1)
★ 20	02-04-0845	Ball Bearing	(1)
★ 21	06-55-0835	8-32 Hex Nut	(2)
★ 22	22-56-0456	Terminal Block	(1)
★ 23	18-31-0200	120 V. Field	(1)
24	43-72-0175	Heat Sink Holder	(1)
25	31-05-0050	Baffle	(1)
★ 26	16-30-0325	120 V. Armature	(1)
27	22-84-0531	Fan Assembly	(1)
★ 28	02-04-0911	Ball Bearing	(1)
29	22-56-0542	Pin Housing Assy.	(1)
30	48-76-4008	Cord Set	(1)

FIG.	PART NO.	DESCRIPTION OF PART	NO. REQ.
31	48-66-3280	Chuck Key	(1)
32	48-66-4040	Key Holder	(1)
33	28-28-0611	Diaphragm	(1)
34	02-50-1640	Needle Bearing	(2)
35	32-40-1241	Intermediate Gear	(1)
36	06-42-0800	Woodruff Key	(2)
37	36-66-2801	Intermediate Shaft	(1)
38	02-04-0640	Ball Bearing	(1)
39	02-50-2440	Needle Bearing	(1)
40	32-75-2061	Spindle Gear	(1)
41	34-60-1200	Retaining Ring	(1)
42	32-75-2041	Spindle Gear	(1)
★ 43	36-66-4002	Intermediate Shaft	(1)
44	02-04-0820	Ball Bearing	(1)
45	28-14-1920	Gear Case	(1)
46	43-62-0875	Side Handle	(1)
47	02-04-1536	Ball Bearing	(1)
48	34-80-2500	Retaining Ring	(1)
★ 49	06-82-7453	8-16 x 2-1/4" Pan Hd. Plastite T-20	(2)
★ 50	06-82-7354	8-16 x 1-3/8" Pan Hd. Plastite T-20	(1)
51	06-42-1600	Woodruff Key	(1)
52	38-50-5470	Spindle	(1)
53	48-66-1360	1/2" Chuck	(1)
54	06-75-3150	1/4-20 x 1 L.H. Skt. Cap Screw	(1)
★ 55	44-60-0530	Ground Pin	(1)
★ 56	45-12-0470	Dust Shield	(1)

**LUBRICATION:**

45 3-1/4 Oz. Type "A" Grease, No. 49-08-0800.

**MILWAUKEE ELECTRIC TOOL CORPORATION**  
13135 W. LISBON RD., BROOKFIELD, WI 53005