



# SERVICE PARTS LIST

**BULLETIN NO.**  
54-08-1185

SPECIFY CATALOG NO. AND SERIAL NO. WHEN ORDERING PARTS		REVISED BULLETIN 54-08-1184	DATE Oct. '84
<b>1/2" REVERSING DRILL</b>			
<b>CATALOG NO. 1101-1</b>		<b>STARTING SERIAL NO. 493-175000</b>	
<b>CAT. NO. 1101-6</b>		<b>START SER. NO. 493-175000</b>	
<b>BILINGUAL LABEL 10-98-6400</b>			

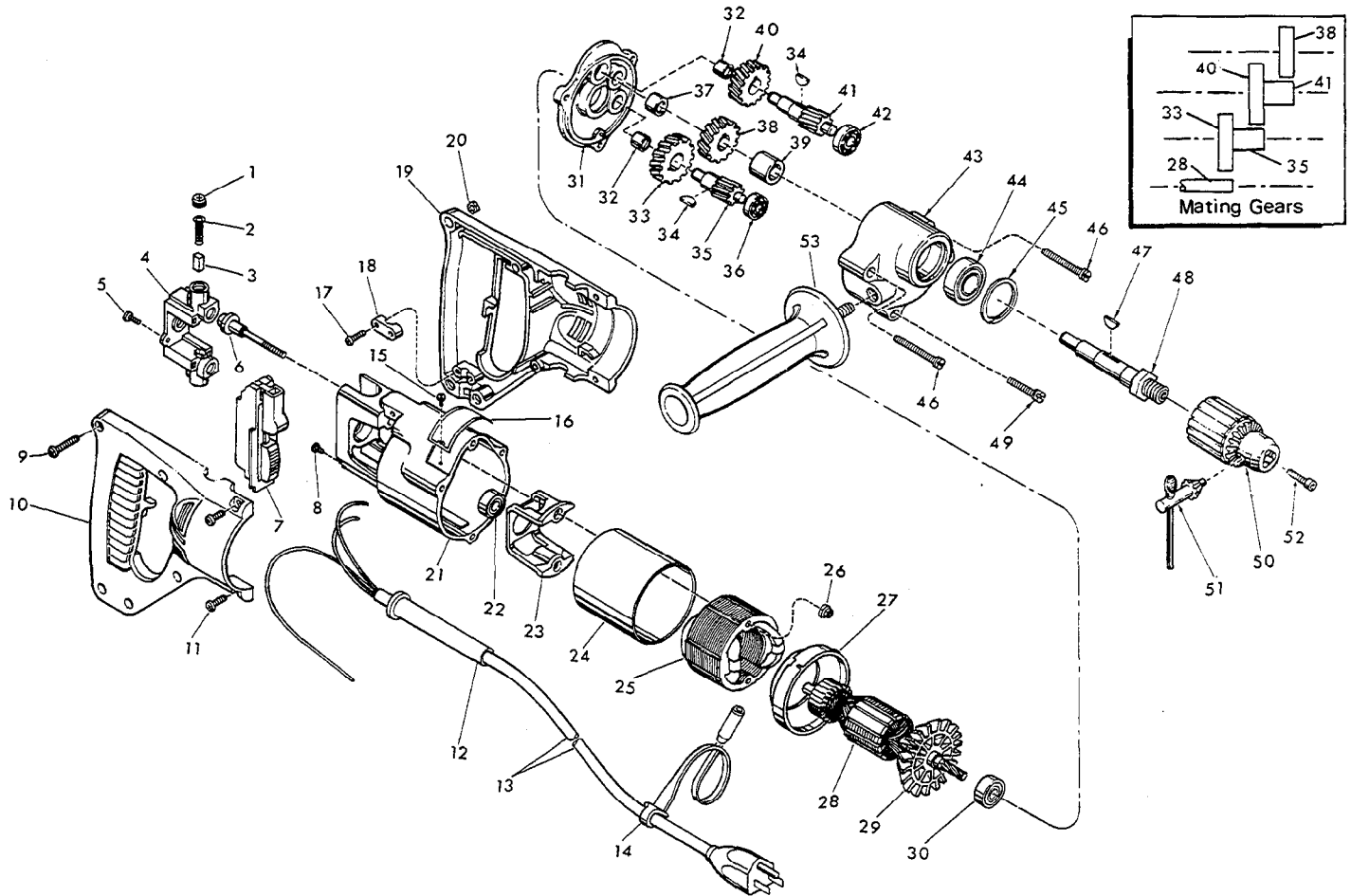

FIG.	PART NO.	DESCRIPTION OF PART	NO. REQ.
★ 1	23-44-0190	Brush Retaining Screw	(2)
2	23-52-0160	Brush Spring	(2)
★ 3	22-16-0275	Carbon Brush	(2)
★ 4	22-22-1330	Brush Holder Assembly	(1)
★ 5	06-95-0075	6-32 x 3/8 Trus Hd. Taptite Screw	(2)
★ 6	06-81-1058	Insulated Field Bolt	(2)
7	23-66-1020	Switch	(1)
8	06-95-5150	Ground Screw	(1)
9	06-81-0473	8-32 x 1" Pan Hd. Pozidriv Screw	(5)
★ 10	31-44-1300	R.H. Half D Handle	(1)
★ 11	06-95-0700	8-32 x 1/2" Pan Hd. Taptite Screw	(4)
★ 12	44-76-0150	Cord Protector	(1)
★ 13	22-64-0155	Cord Set	(1)
14	48-66-4040	Key Holder	(1)
15	06-85-0200	6 x 1/4 Rd. Hd. Type Z Screw	(2)
16	12-99-0030	Nameplate	(1)
★ 17	06-95-0216	8-16 x 5/8" Plastite Screw	(2)
★ 18	31-17-0156	Cord Clamp	(1)
★ 19	31-44-1305	L.H. Half D Handle	(1)
20	06-55-0835	8-32 Hex Nut	(5)
★ 21	28-50-6201	Motor Housing	(1)
★ 22	02-04-0845	Ball Bearing	(1)
23	31-55-0030	Coil Shield	(1)
24	23-16-0456	Field Insulator	(1)
25	18-30-0200	120 V. Field	(1)
26	06-57-2975	8-32 Flexlock Hex Nut	(2)
27	31-05-0050	Baffle	(1)
★ 28	16-30-0325	120 V. Armature (Incl. Fig. No. 29)	(1)
29	22-84-0530	Fan Assembly	(1)

FIG.	PART NO.	DESCRIPTION OF PART	NO. REQ.
★ 30	02-04-0911	Ball Bearing	(1)
★ 31	28-28-0665	Diaphragm	(1)
32	02-50-1640	Needle Bearing	(2)
33	32-40-1241	Intermediate Gear	(1)
34	06-42-0800	Woodruff Key	(2)
35	36-66-2801	Intermediate Shaft	(1)
36	02-04-0640	Ball Bearing	(1)
37	02-50-2110	Needle Bearing	(1)
38	32-75-2061	Spindle Gear	(1)
39	45-36-0210	Spindle Gear Spacer	(1)
40	32-75-2041	Spindle Gear	(1)
41	36-66-4001	Intermediate Shaft	(1)
42	02-04-0820	Ball Bearing	(1)
43	28-14-0691	Gear Case	(1)
44	02-04-1560	Ball Bearing	(1)
45	34-80-2500	Retaining Ring	(1)
★ 46	06-95-5270	8-32 x 1-7/8 Fil. Hd. Sem	(2)
47	06-42-1600	Woodruff Key	(1)
48	38-50-3651	Spindle	(1)
★ 49	06-95-5250	8-32 x 1-1/8 Fil. Hd. Sem	(1)
50	48-66-1360	1/2" Chuck (Includes Fig. No. 51)	(1)
51	48-66-3280	Chuck Key	(1)
52	06-75-3150	1/4-20 x 1 L.H. Skt. Hd. Cap Screw	(1)
★ 53	43-62-0875	Side Handle	(1)
54	10-98-5987	Warning Label Omit For Canadian Tools	(1)

**MILWAUKEE ELECTRIC TOOL CORPORATION**  
13135 W. LISBON RD., BROOKFIELD, WIS. 53005