



SERVICE PARTS LIST

BUL. 54-08-1160

1/2" DRILL

REVISED BUL. DATE
Feb. '73

Catalog No. 1101

Starting Serial No. **492-1001**

WIRING INSTRUCTIONS
58-01-0175

Specify Catalog and Serial No. when ordering parts

500 R.P.M.

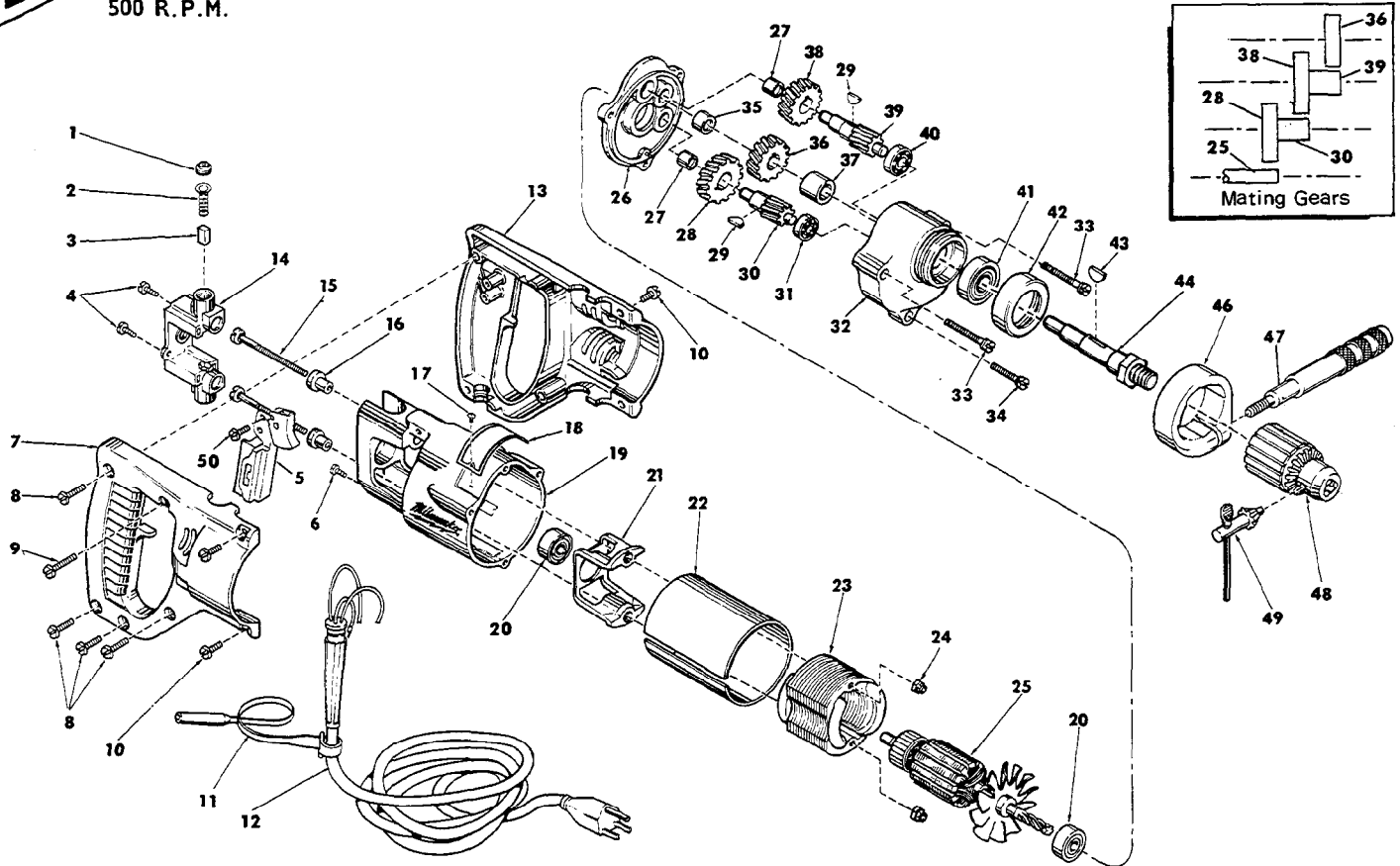

FIG.	PART NO.	DESCRIPTION OF PART	NO. REQ.	FIG.	PART NO.	DESCRIPTION OF PART	NO. REQ.
1	23-44-0120	Brush Retaining Screw	(2)	27	02-50-1640	Needle Bearing	(2)
2	23-52-0160	Brush Spring	(2)	28	32-40-1241	Intermediate Gear	(1)
3	22-16-0250	Carbon Brush	(2)	29	06-42-0800	Woodruff Key	(2)
4	06-81-5475	6-32x3/8 Binding Hd. Sem	(2)	30	36-66-2801	Intermediate Shaft	(1)
5	23-66-0505	Switch	(1)	31	02-04-0640	Ball Bearing	(1)
6	06-81-8625	6-32x1/4 Ground Screw	(1)	32	28-14-1261	Gear Case	(1)
7	31-44-0370	R.H. Half D Handle	(1)	33	06-81-6705	8-32x1-7/8 Fil. Hd. Sem	(2)
8	06-81-0400	8-32x3/4 Pan Hd. Screw	(4)	34	06-81-6400	8-32x1-1/8 Fil. Hd. Sem	(1)
9	06-81-0470	8-32x1 Pan Hd. Screw	(1)	35	02-50-2110	Needle Bearing	(1)
10	06-81-0045	8-32x1/2 Pan Hd. Screw	(4)	36	32-75-2061	Spindle Gear	(1)
11	48-66-4040	Key Holder	(1)	37	45-36-0210	Spindle Gear Spacer	(1)
12	22-64-0385	Cord Set	(1)	38	32-75-2041	Spindle Gear	(1)
13	31-44-0380	L.H. Half D Handle	(1)	39	36-66-4001	Intermediate Shaft	(1)
14	22-22-0300	Brush Holder Assembly	(1)	40	02-04-0820	Ball Bearing	(1)
15	06-81-1050	8-32x2-7/16 Field Bolt	(2)	41	02-04-1560	Ball Bearing	(1)
16	31-86-0120	Insulating Spacer	(2)	42	42-52-0071	Bearing Cap	(1)
17	06-85-0200	6x1/4 Rd. Hd. Type Z Screw	(2)	43	06-42-1600	Woodruff Key	(1)
18	12-99-0030	Nameplate	(1)	44	38-50-3601	Spindle	(1)
19	28-50-6141	Motor Housing	(1)	45	49-15-0200	Side Handle Assy. (Includes Nos. 46 & 47)	(1)
20	02-04-0940	Ball Bearing	(2)	46	28-82-0130	Handle Ring	(1)
21	31-55-0080	Coil Shield	(1)	47	43-62-0160	Side Handle	(1)
22	23-16-0435	Field Insulator	(1)	48	48-66-1280	1/2" Chuck (Includes Fig. No. 49)	(1)
23	18-42-1040	115 V. Field	(1)	49	48-66-3280	Chuck Key	(1)
24	06-57-2975	8-32 Flexlock Hex Nut	(2)	50	06-81-5500	8-32 x 3/8 Binding Hd. Sem	(2)
25	16-42-1410	115 V. Armature	(1)				
26	28-28-0661	Diaphragm	(1)				