



SERVICE PARTS LIST

BULLETIN NO.
54-08-1203

SPECIFY CATALOG NO. AND SERIAL NO. WHEN ORDERING PARTS		REVISED BULLETIN 54-08-1202	DATE Oct. '87
1/2" REVERSING DRILL			
CATALOG NO. 1007-1	STARTING SERIAL NO. 628-21000	WIRING INSTRUCTION 58-01-0281	

EXAMPLE:
Component Parts (Small #) Are Included
When Ordering The Assembly Part (Large #).

00-0

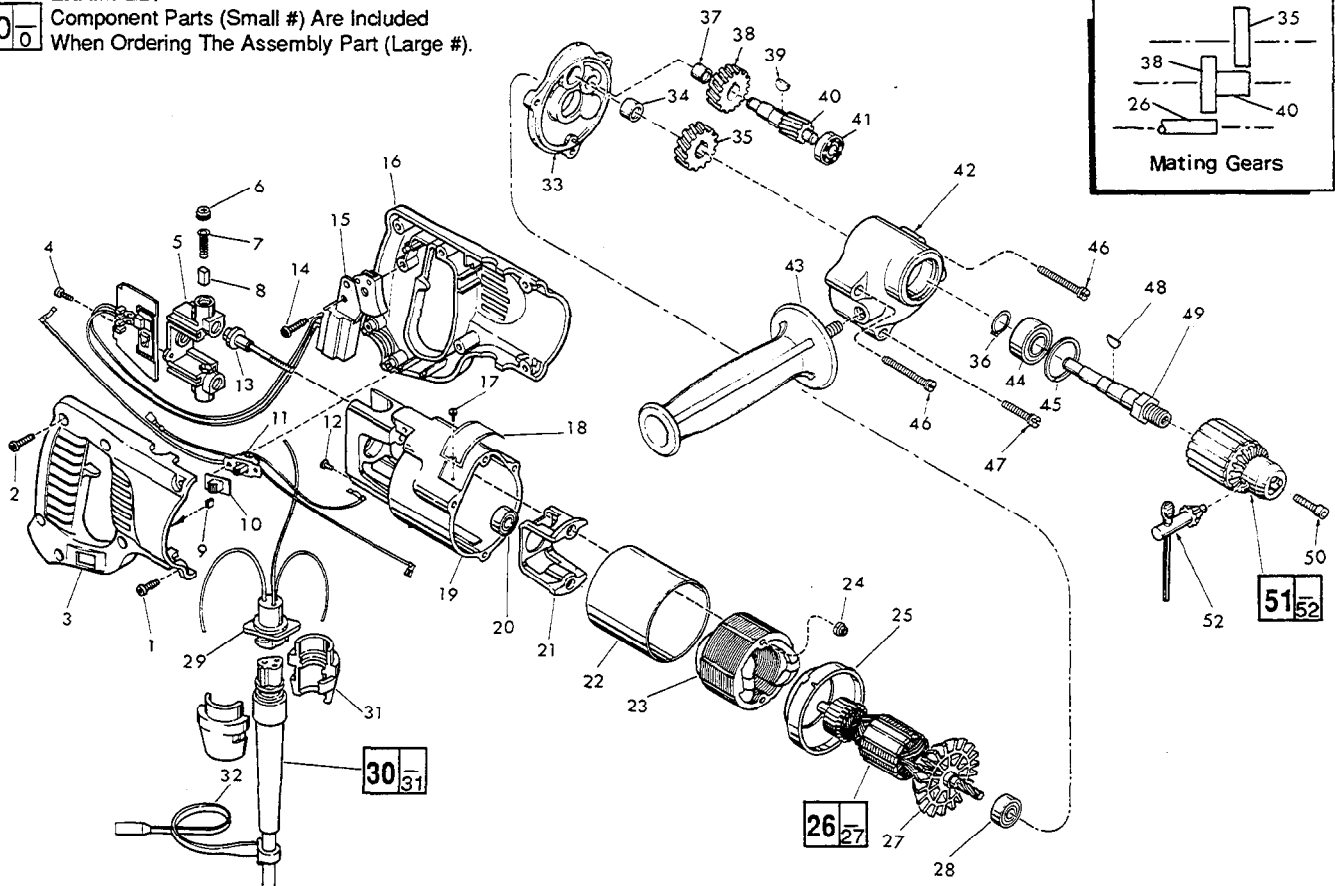

FIG.	PART NO.	DESCRIPTION OF PART	NO. REQ.	FIG.	PART NO.	DESCRIPTION OF PART	NO. REQ.
★ 1	06-82-5316	8-32x1/2" Slot Pan Hd. Torx Screw	(4)	31	44-40-0440	Cord Nut	(2)
★ 2	06-82-7260	7-18 x 5/8" Pan Hd. Plastite Torx Screw	(5)	32	48-66-4040	Key Holder	(1)
★ 3	31-44-1476	Right Handle Half	(1)	★ 33	28-28-0586	Diaphragm	(1)
4	06-95-0075	6-32 x 3/8" Truss Hd. Taptite Screw	(2)	34	02-50-2440	Needle Bearing	(1)
5	22-22-1330	Brush Holder Assembly	(1)	35	32-75-1601	Spindle Gear	(1)
6	23-44-0190	Brush Retaining Cap	(2)	36	34-60-1200	Retaining Ring	(1)
7	23-52-0160	Brush Spring	(2)	37	02-50-1640	Needle Bearing	(1)
8	22-16-0275	Carbon Brush	(2)	38	32-40-1241	Intermediate Gear	(1)
★ 9	42-38-0240	Bumper	(2)	39	06-42-0800	Woodruff Key	(1)
★ 10	31-12-0195	Switch Cap	(1)	40	36-66-2001	Intermediate Shaft	(1)
★ 11	23-66-1454	Switch Assembly	(1)	41	02-04-0640	Ball Bearing	(1)
12	06-95-5150	6-32 x 1/4" Hex Hd. Taptite Sems	(1)	★ 42	28-14-1910	Gear Case	(1)
13	06-81-1058	8-32 x 2.19 Field Bolt	(2)	43	43-62-0875	Side Handle	(1)
14	06-82-7260	7-18 x 5/8" Pan Hd. Plastite Torx Screw	(1)	44	02-04-1536	Ball Bearing	(1)
★ 15	23-66-0955	On-Off Switch	(1)	45	34-80-2500	Retaining Ring	(1)
★ 16	31-44-1481	Left Handle Half	(1)	★ 46	06-82-5502	8-32 x 2-1/4" Pan Taptite Torx	(2)
17	06-85-0200	Nameplate Screw	(2)	★ 47	06-82-5404	8-32 x 1-3/8" Pan Taptite Torx	(1)
★ 18	12-99-0043	Nameplate Blank	(1)	48	06-42-1600	Woodruff Key	(1)
19	28-50-6201	Motor Housing	(1)	49	38-50-5470	Spindle	(1)
20	02-04-0845	Ball Bearing	(1)	50	06-75-3150	1/4-20 x 1 L.H. Skt. Cap Screw	(1)
21	31-55-0030	Coil Shield	(1)	51	48-66-1360	1/2" Chuck Key	(1)
22	23-16-0456	Field Insulator	(1)	52	48-66-3280	Chuck Key	(1)
23	18-30-0200	120 V. Field	(1)				
24	06-57-2975	8-32 Flexlock Hex Nut	(2)				
25	31-05-0050	Baffle	(1)				
26	16-30-0325	120 V. Armature	(1)				
27	22-84-0530	Fan Assembly	(1)				
28	02-04-0911	Ball Bearing	(1)				
★ 29	22-56-0540	Pin Housing Assy.	(1)				
30	48-76-3008	Cord Set	(1)				

LUBRICATION:
42 3-1/4 Oz. Type "A" Grease, 49-08-0800.