

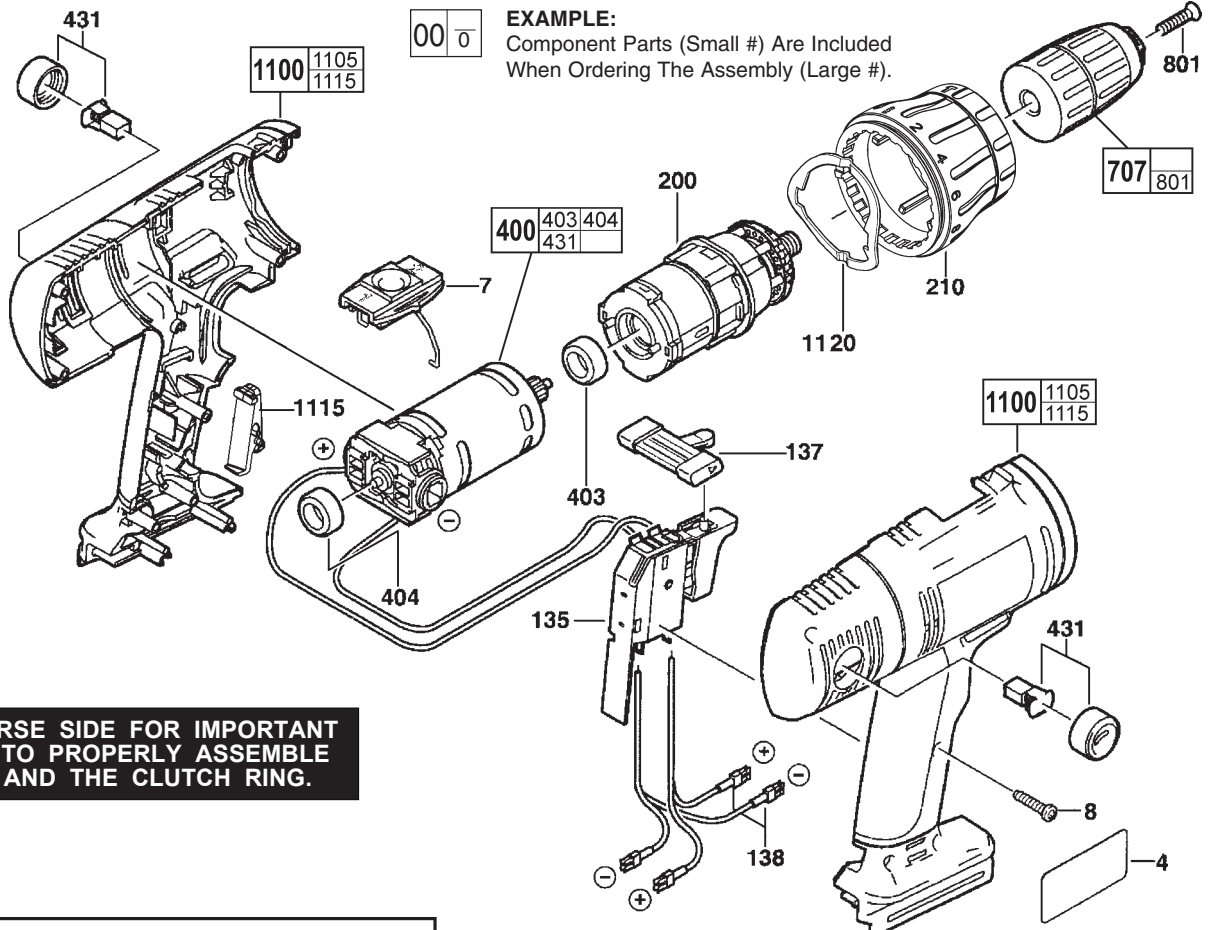

SERVICE PARTS LIST

BULLETIN NO.
54-24-4051

SPECIFY CATALOG NO. AND SERIAL NO. WHEN ORDERING PARTS		REVISED BULLETIN	DATE
18 Volt 1/2" Lok-Tor™ Hammer Driver Drill		54-24-4050	Jan. 2005
CATALOG NO. 0624-20	STARTING SERIAL NO. 321B	WIRING INSTRUCTION SEE INSERT	



EXAMPLE:
Component Parts (Small #) Are Included
When Ordering The Assembly (Large #).

SEE THE REVERSE SIDE FOR IMPORTANT INSTRUCTIONS TO PROPERLY ASSEMBLE THE GEARBOX AND THE CLUTCH RING.

NOTE:
Proper polarity in the terminal block requires leads to be crossed, as illustrated.

Long lead to the upper (+) motor terminal

Short lead to lower motor terminal

Long lead (+)

Short lead (-)

WARNING!
Switch polarity sensitive if wired incorrectly with the terminal block(1105). The switch will be damaged and destroyed.

* = Part number change from previous service parts list.

FIG.	PART NO.	DESCRIPTION OF PART	QTY.
1	49-15-0400	Side Handle (Not Shown)	(1)
4	12-20-1080	Service Nameplate	(1)
7	45-24-0090	Slide High / Low	(1)
8	06-82-7236	4-20 x 5/8" Pan Hd. Plastite T-10	(7)
135	23-66-0605	Switch	(1)
137	45-24-0510	Reversing Shuttle	(1)
138	23-94-3630	Lead Wire Assembly (Set of 2)	(1)
★ 200	14-29-0145	Gearbox Assembly	(1)
★ 210	43-76-0800	Clutch Ring	(1)
400	23-30-0475	Motor Assembly	(1)
403	45-22-0340	Front Rubber Sleeve	(1)
404	45-22-0560	Rear Rubber Sleeve	(1)
431	22-18-1150	Brush Assembly	(1)
707	48-66-1575	Keyless Chuck	(1)
801	05-80-0450	Chuck Screw	(1)
1100	31-50-1646	Handle Kit	(1)
1105	22-56-0200	Connector Block	(1)
1115	31-53-0230	Finger Grip	(1)
★ 1120	40-50-1130	Detent Spring	(1)

22-18-1150 BRUSH ASSEMBLY
THIS ASSEMBLY INCLUDES:

2	-----	Carbon Brush
2	-----	Brush Cap

SETTING THE CLUTCH RETAINING COLLAR

- **NOTE:** Triangle ▲ of rear gearbox assembly housing is aligned with square ■ located on front housing.

Begin assembly by aligning the retaining collar triangle ▲ with front housing square ■ and rear gearbox triangle ▲ at the 12 o'clock ⌚ position.

- Turn retaining collar clockwise until clutch spring is fully collapsed. Retaining collar triangle ▲ should be at approximately the 12 o'clock ⌚ position to the front housing square ■ and the rear gearbox triangle ▲.
- If the front retaining collar triangle ▲ stops at approximately the 5 o'clock ⌚ position, the retaining collar will have been installed 180° off. This requires unthreading and rethreading of the collar for proper threading is with triangles ▲ aligned.
- When fully compressed, make sure the retaining collar triangle ▲ is in line with the front housing square ■ and rear gearbox triangle ▲.

Gearbox square ■ and triangle ▲ are whitened for reference only.

Triangle ▲ of rear gearbox assembly housing is aligned with square ■ located on front housing.

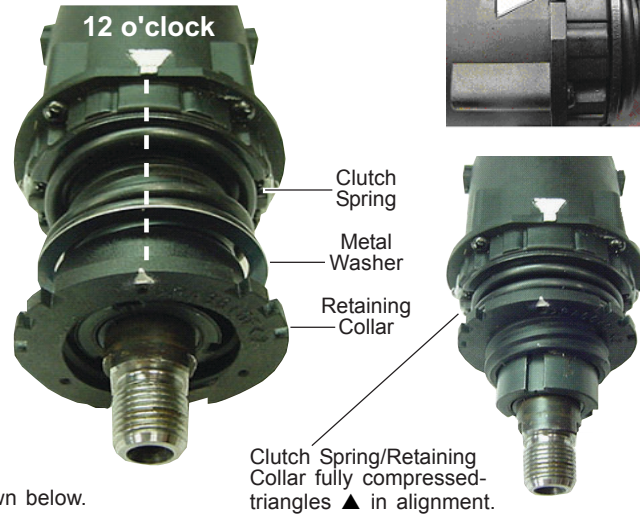

☞ Clutch collar triangles ▲ on a few gearboxes may be slightly to the left of the center 12 o'clock position when tightened, as shown below.

STEP 1

CHECKING / SETTING THE HAMMER SHIFT COLLAR

The following must be in place:

- Clutch collar triangle ▲ (tight) in-line, slightly to the left of gearbox 12 o'clock ⌚ position. (Set in step 1).
- Washer [A] visible above hammer shift collar, (fig. 2).
- Hammer Shift Collar [B] notch [1] with the .160 wide notch in-line or slightly left of gearbox 12 o'clock position (fig. 1).

☞ If hammer Shift Collar [B] is out of position, it will look like example shown in (fig. 3).

Rotate shift collar left or right by hand until it drops into position shown in (fig. 2). The washer must be visible, and the .160 wide shift collar notch [1] must be in-line or slightly left of top 12 o'clock position, as viewed from the front of the gearbox.

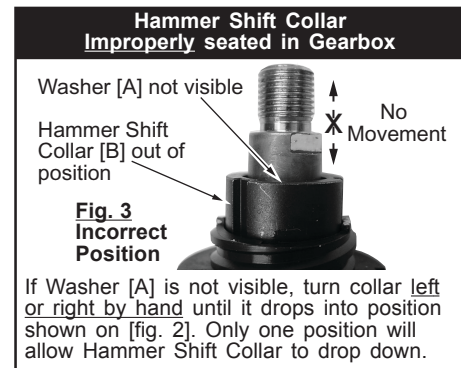
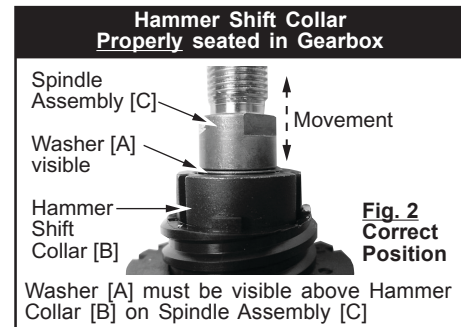
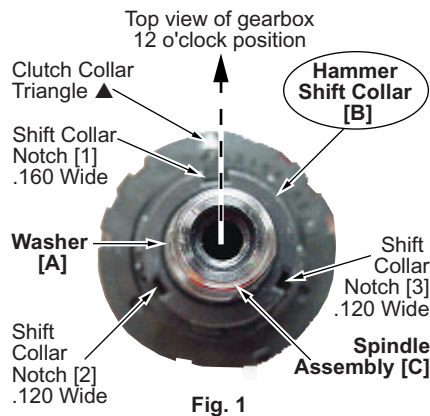

STEP 2

LOCATING RAISED GEARBOX NOTCHES FOR CLUTCH RING SPRING ASSEMBLY

Locate clutch ring spring notches by first identifying...

- The triangle ▲ on top of retaining collar [4].
- Raised gearbox notch [1] located at approx. 9 o'clock position.
- Raised gearbox notch [2] located at approx. 3 o'clock position. (Notch [1] and [2] located 180° apart on gearbox [5], as viewed from front of gearbox).
- Raised gearbox notch [3]. (Will not contact clutch ring spring).

Proceed to STEP 4.

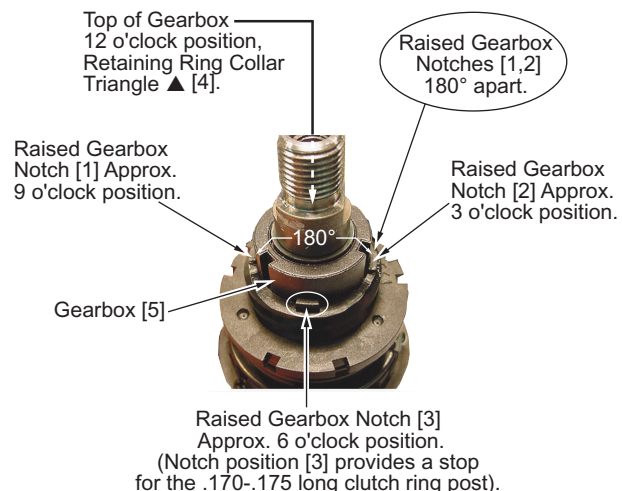

STEP 3

INSTALLING CLUTCH RING SPRING ONTO GEARBOX

- Position clutch ring spring [3] above gearbox [5]. (Cup of spring to face up).
- Position clutch ring spring notches [1,2] over raised gearbox notches [1,2]. (Make sure spring is seated flat and fits firmly over both raised gearbox notches).

Proceed to **RECAPPING STEPS 1,2,3,4.**

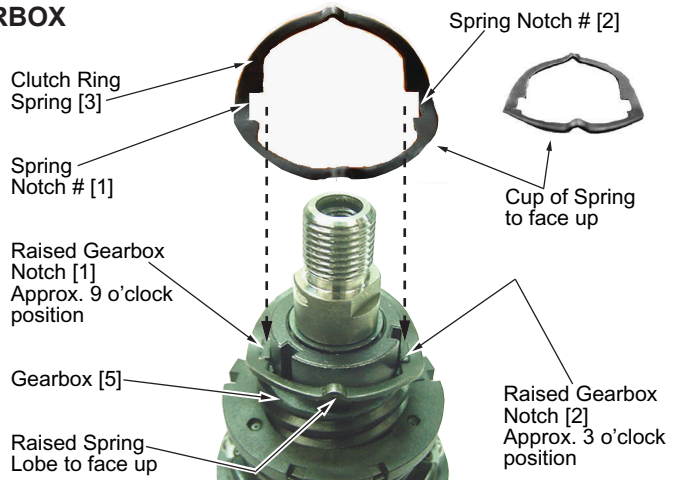

STEP 4

RECAPPING STEPS 1,2,3,4

- Retaining collar [4] should be tightened completely (clockwise) with triangle ▲ in-line or slightly to the left of top 12 o'clock position.
- Shift collar notch [1] with a .160 wide opening must be in-line or slightly to the left of the 12 o'clock position of front gearbox. (Widest of the three openings in the shift collar).
- Raised spring lobes will be in-line with the 12 and 6 o'clock position of front gearbox.

Proceed to **STEP 5.**

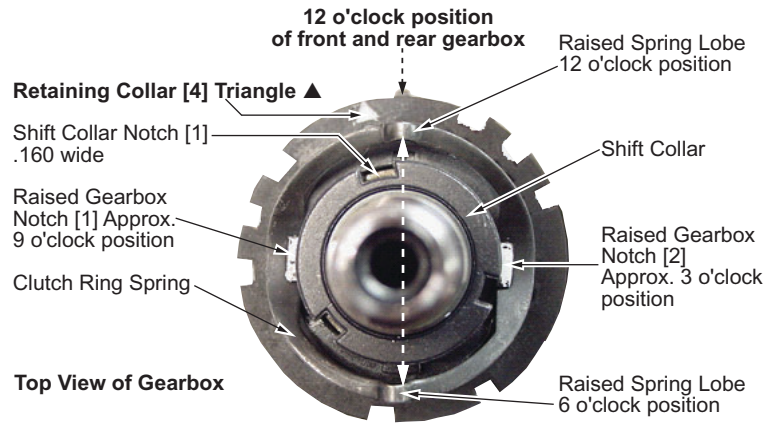

INSTALLING CLUTCH RING ONTO GEARBOX

Before installing clutch ring assembly [A,B] onto gearbox...

- Identify internal clutch ring [A] components and the corresponding widths.
- Concentrate on the main clutch ring post when installing the clutch collar assembly. The main post [E] is the widest of the three, with a width of approximately .160.

Proceed to **STEP 6.**

NOTE: Front Clutch Ring section [A] has been removed from section [B] for illustration Only. Section [A,B] should remain together and not separated.

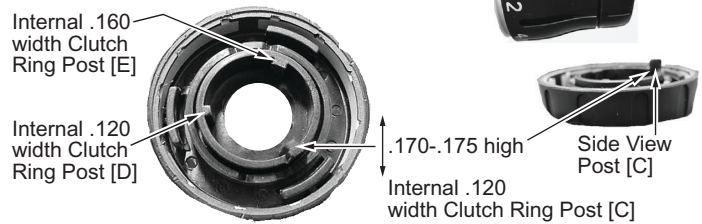

Rear view of (outside) Clutch Ring [A] to illustrate internal Clutch Ring Post widths and positions.

STEP 5

INSTALLING CLUTCH RING ONTO GEARBOX

- Align two piece clutch assembly [A,B], as shown in fig. 1.
- Turn clutch ring assembly to position shown in fig. 2 to view internal clutch ring posts [C,D,E] for correct position prior to assembling clutch ring to gearbox.

Proceed to **STEP 7.**

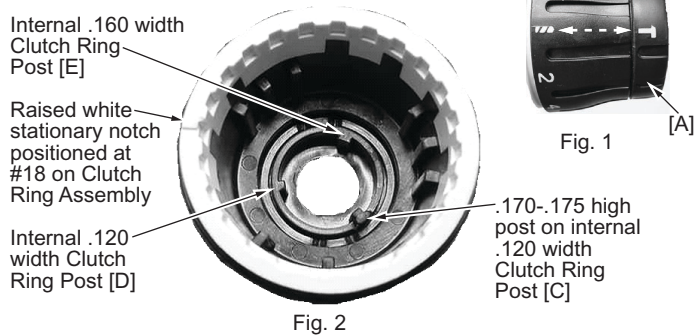

12 o'clock position of Clutch Ring [B] will have the Drill Symbol .



Picture shown with hammer symbol T aligned with drill symbol . ready for assembly.

STEP 6

INSTALLING CLUTCH RING ONTO GEARBOX

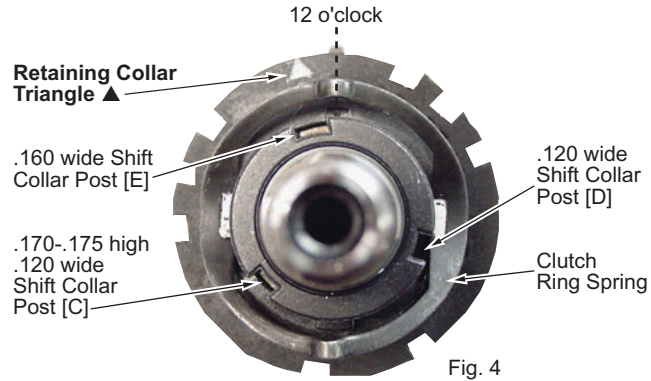
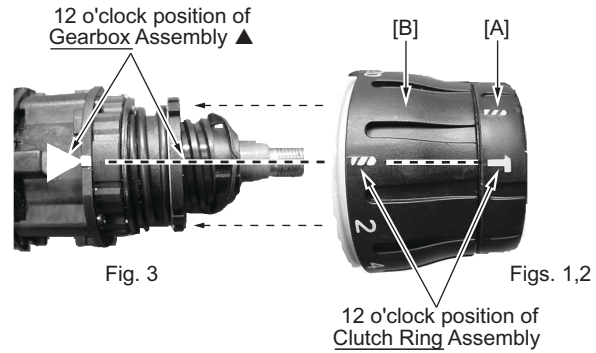

- Hold gearbox assembly, fig. 3 in one hand with the 12 o'clock position facing up.
- Install clutch ring assembly, figs. 1,2 over gearbox assembly, fig. 3 in direction of arrows.
- Make sure drill symbol  and hammer symbol  stay in-line with the top 12 o'clock position of the gearbox when installing clutch ring.
- Failure to hold clutch ring symbols together, as shown in figs. 1,2, when installing clutch ring assembly, will result in a misalignment of the internal clutch ring post, shown / illustrated in step 5.

Proceed to **STEP 8**.



STEP 7

TOP VIEW OF GEARBOX WITH CLUTCH RING INSTALLED

- Triangle ▲ and square ■ located on gearbox [C], should be in-line with drill symbol  and hammer symbol  on clutch ring assembly [A,B].

Proceed to **STEP 9**.

 Gearbox square ■ and triangle ▲ are highlighted for reference only.

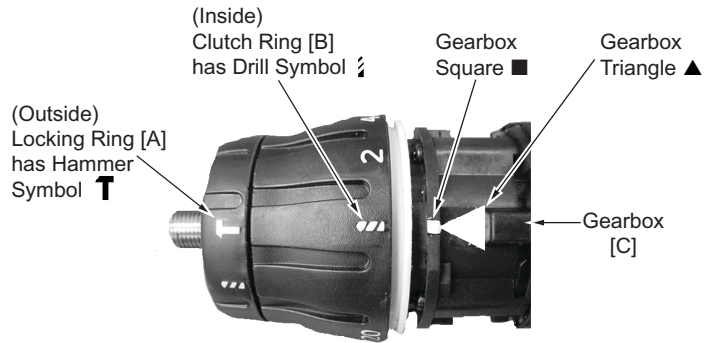

STEP 8

RIGHT SIDE OF GEARBOX WITH CLUTCH RING INSTALLED (As viewed from the front of the gearbox)

- Clutch ring [A,B], when properly installed, will have the number 18 and raised white stationary notch [D] (as viewed from the front of the gearbox) on the right side of gearbox [C] in-line with gearbox steel ball [E].

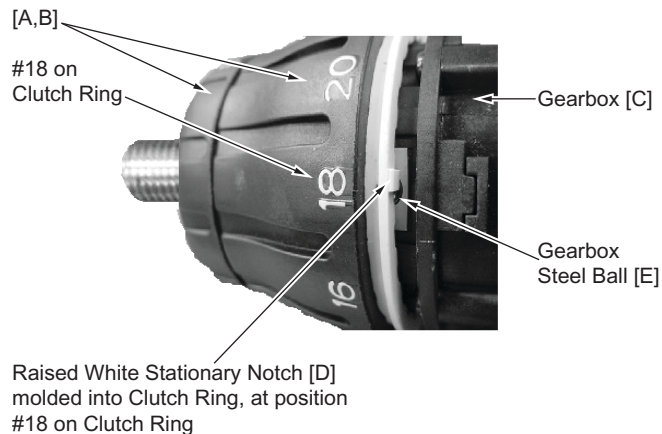

STEP 9