



# SERVICE PARTS LIST

BULLETIN NO.  
54-06-1425

SPECIFY CATALOG NO. AND SERIAL NO. WHEN ORDERING PARTS		REVISED BULLETIN	DATE
12 VOLT 1/2" POWER PLUS DRIVER-DRILL			Oct. 2001
CATALOG NO. 0501-02, 0501-20	SERIAL NUMBER 900A	WIRING INSTRUCTION <b>SEE REVERSE SIDE</b>	

EXAMPLE:  
 Component Parts (Small #) Are Included  
 When Ordering The Assembly (Large #).

00 0

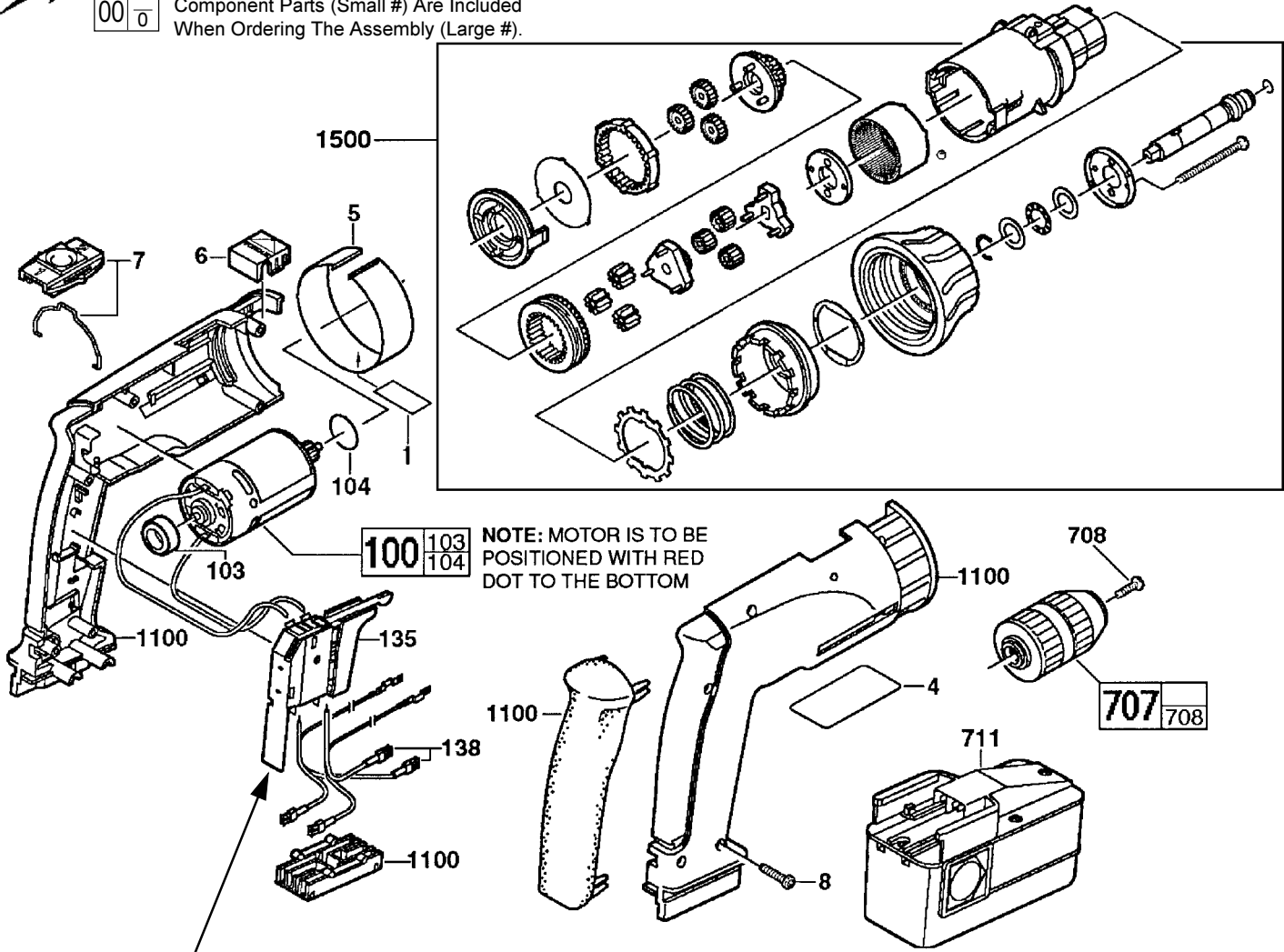

NOTE: MOTOR IS TO BE POSITIONED WITH RED DOT TO THE BOTTOM

**⚠ WARNING**  
**SWITCH POLARITY SENSITIVE**  
 If wired incorrectly with housing assembly, (fig. 1100), switch **will be** damaged and destroyed!  
 See reverse side of bulletin for switch wiring detail.

FIG.	PART NO.	DESCRIPTION OF PART	NO. REQ.
1	10-15-9525	Warning Label	1
4	12-20-0501	Service Nameplate	1
5	45-22-0075	Sleeve	1
6	31-12-0215	Cap	1
7	45-24-1195	Slide High/Low	1
8	06-82-7236	Screw	6
100	23-30-0105	Motor	1
103	45-22-0570	Rubber Sleeve	1
104	34-40-2005	O-Ring	1
135	23-66-1265	Switch	1
138	23-94-9005	Lead Wire Assembly	1
707	48-66-0365	Keyless Chuck	1
708	06-81-2925	Chuck Screw-Left Hand Thread	1
711	-----	Battery Pack	1
1100	31-50-0485	Housing Assembly	1
1500	14-29-0080	Gear Box Assembly	1

**!**  
**WARNING**

**SWITCH POLARITY SENSITIVE**  
IF WIRED INCORRECTLY WITH  
HOUSING ASSEMBLY, (FIG. 1100),  
SWITCH **WILL BE** DAMAGED AND  
DESTROYED.

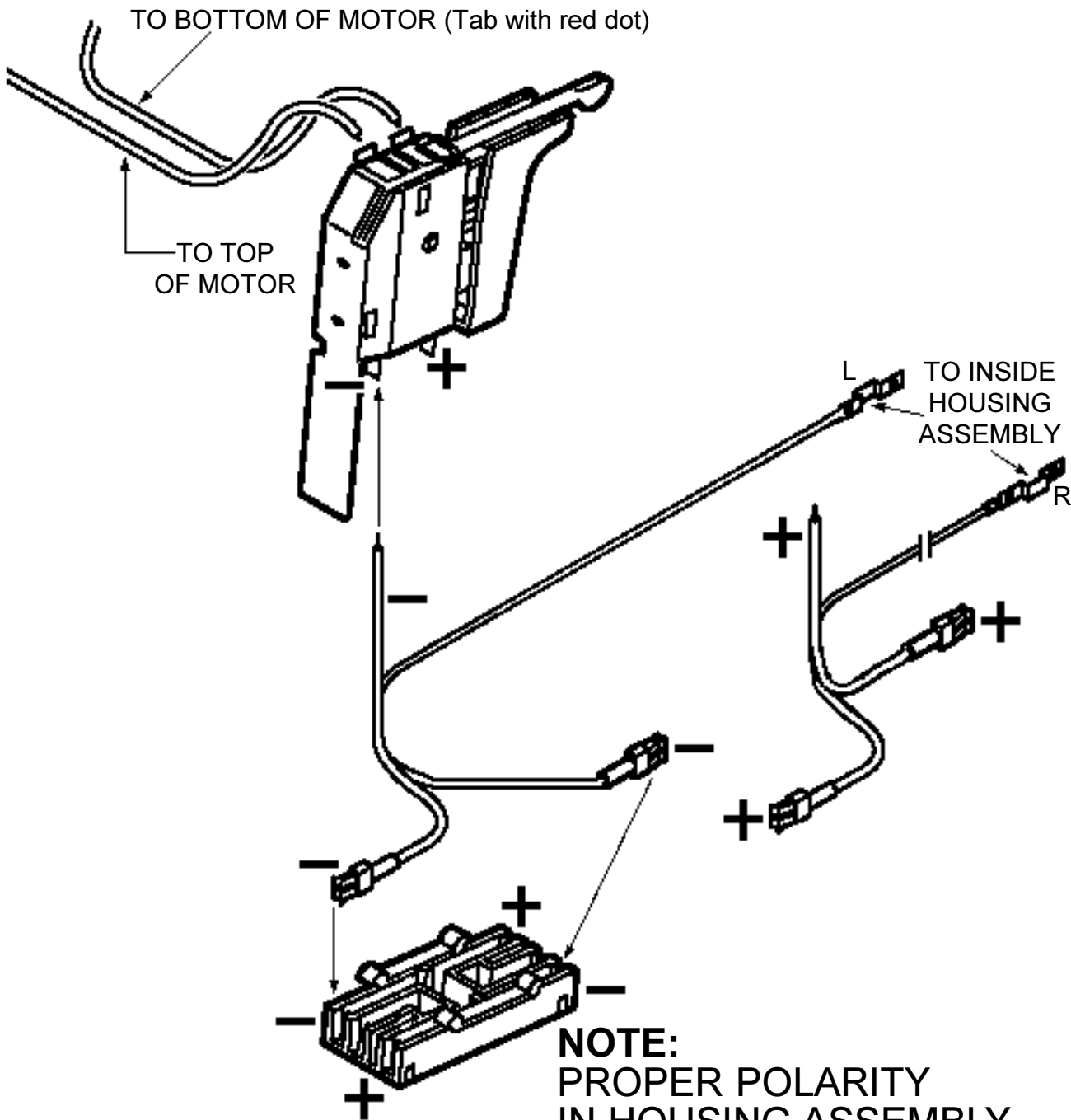

**NOTE:**  
PROPER POLARITY  
IN HOUSING ASSEMBLY  
REQUIRES LEADS  
TO BE CROSSED  
AS ILLUSTRATED .