



SERVICE PARTS LIST

BULLETIN NO.
54-06-1075

SPECIFY CATALOG NO. AND SERIAL NO. WHEN ORDERING PARTS		REVISED BULLETIN	DATE
12 VOLT 3/8" CORDLESS DRILL			June '96
CATALOG NO.	0445-1	STARTING SERIAL NO.	849A
		WIRING INSTRUCTION 58-01-1605	

EXAMPLE:

Component Parts (Small #) Are Included
When Ordering The Assembly (Large #).

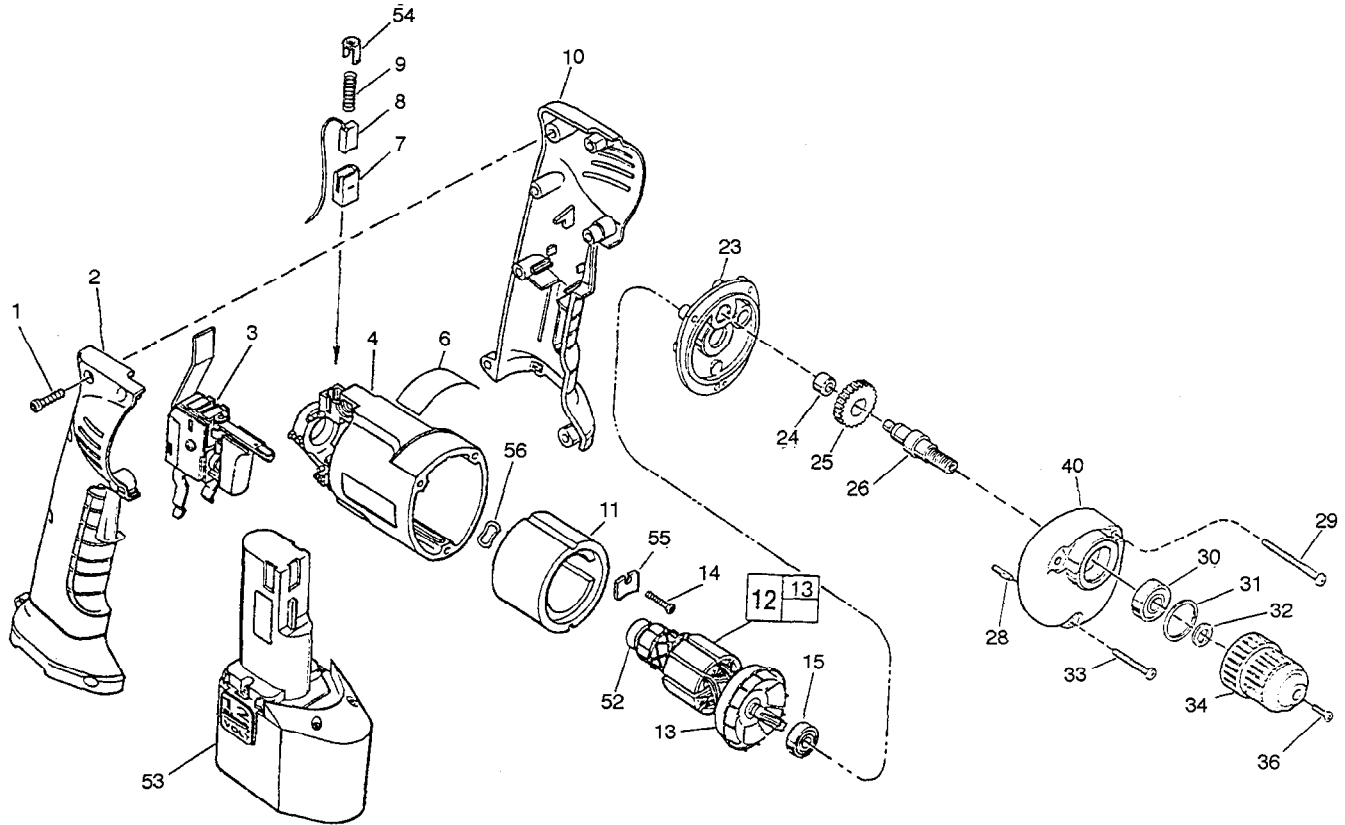

FIG.	PART NO.	DESCRIPTION OF PART	NO. REQ.
1	06-82-9207	6-32 x 11/16" Pan Hd. Slit. Plast. T-20	(7)
2	31-44-1885	Right Handle Half	(1)
3	23-66-2300	Speed Control Switch	(1)
4	31-50-1080	Motor Housing	(1)
6	12-20-1175	Service Nameplate Kit	(1)
7	22-20-0860	Brush Tube	(2)
8	22-18-0840	Brush Assembly - Top	(1)
	22-18-0845	Brush Assembly - Bottom	(1)
9	40-50-8775	Brush Spring	(2)
10	31-44-1880	Left Handle Half	(1)
11	18-01-0020	Field	(1)
12	16-01-0030	Armature	(1)
13	22-84-0760	Fan Assembly	(1)
14	06-82-7261	6-19 x 11/16" Pan Hd. Slit. Plast. T-20	(1)
15	02-04-0847	Ball Bearing	(1)
23	28-28-1950	Diaphragm	(1)
24	02-50-1620	Needle Bearing	(1)
25	32-75-3460	Spindle Gear	(1)
26	38-50-5670	Spindle	(1)
28	06-65-0825	18" x 1/2" Groove Pin 5	(1)
29	06-82-7344	7-18 x 1-1/2" Pan Hd. Slit. Plast. T-20	(2)
30	02-04-1020	Ball Bearing	(1)
31	34-80-1400	Retaining Ring	(1)
32	45-88-7940	Chuck Washer	(1)
33	06-82-7308	7-18 x 1-1/8" Pan Hd. Slit. Plast. T-20	(1)
34	48-66-0390	3/8" Chuck	(1)
36	45-04-0750	Chuck Screw-L.H. Thread	(1)
40	28-14-1831	Gear Case	(1)

FIG.	PART NO.	DESCRIPTION OF PART	NO. REQ.
52	02-04-5130	Ball Bearing	(1)
53	48-11-0200	12 Volt Battery	(1)
54	22-32-0400	Brush Spring Clip	(2)
55	44-66-6140	Mounting Plate	(1)
56	45-88-5615	Wavy Spring Washer	(1)
	10-15-9485	Warning Label	(1)
	10-15-9490	Logo Label	(1)

FIG. LUBRICATION

40 1/2 Oz. Type "E" Grease, No. 49-08-4122. Place near intermediate shaft ball bearing in gear case.

FIG. NOTES

- 4,7,8 Slot on brush tube must be assembled on the same side as slot on motor housing. Brush assemblies must be inserted with the wire laying inside of brush tube slot. Brush must slide freely inside brush tube.
- 7,54 Brush spring clip must snap into detent of brush tube.
- 11 Press chamfer end first.
- 15 Seal towards armature.
- 24 Press flush to casting surface.
- 29, 33 Torque to 15-20 In./Lbs.
- 30 Seal towards chuck.

MILWAUKEE ELECTRIC TOOL CORPORATION
13135 W. LISBON RD., BROOKFIELD, WI 53005