



SERVICE PARTS LIST

BULLETIN NO.
55-24-0150

SPECIFY CATALOG NO. AND SERIAL NO. WHEN ORDERING PARTS		REVISED BULLETIN	DATE
12 VOLT PISTOL HAMMER DRILL			June '95
CATALOG NO. 0422-4	STARTING SERIAL NO. 851A	WIRING INSTRUCTION 58-01-1605	

EXAMPLE:

00	0
----	---

 Component Parts (Small #) Are Included When Ordering The Assembly (Large #).

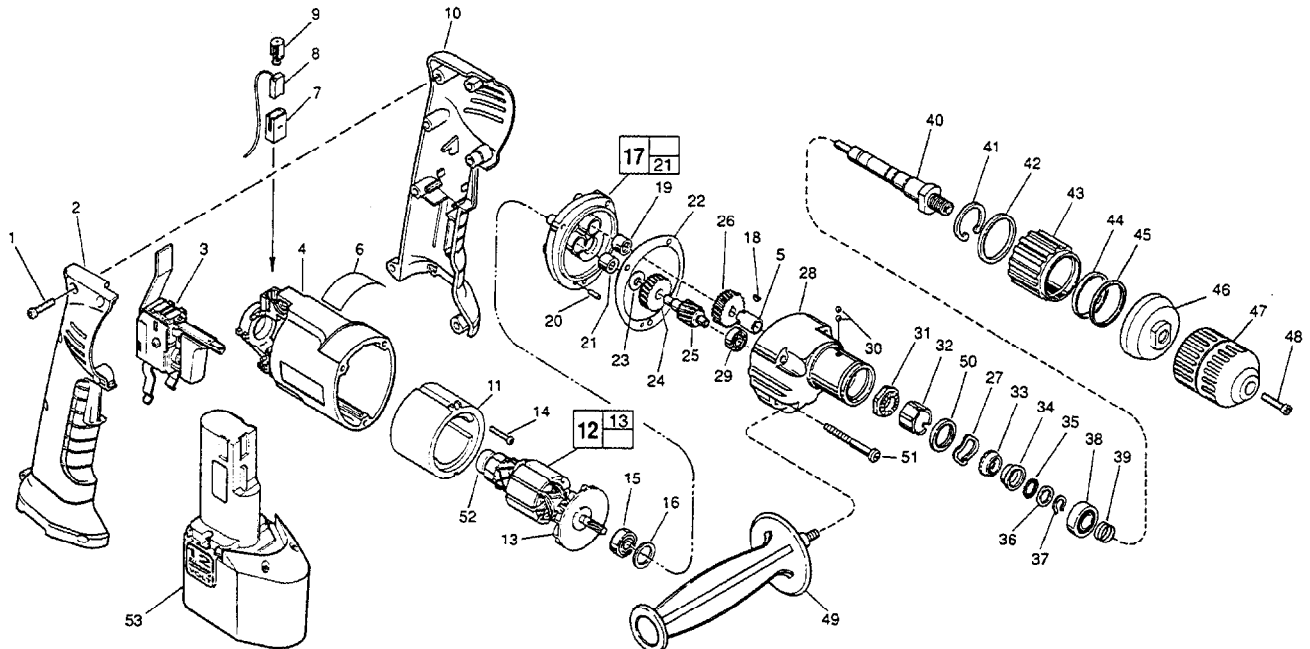

FIG.	PART NO.	DESCRIPTION OF PART	NO. REQ.
1	06-82-9207	6-32 x 11/16" Pan Hd. Slit. Plast. T-20	(7)
2	31-44-1885	Right Handle Half	(1)
3	23-66-2300	Speed Control Switch	(1)
4	31-50-1080	Motor Housing	(1)
5	45-36-1260	Gear Spacer	(1)
6	12-20-1230	Service Nameplate Kit	(1)
7	22-20-0860	Brush Tube	(2)
8	22-18-0840	Brush Assembly - Top	(1)
	22-18-0845	Brush Assembly - Bottom	(1)
9	40-50-8840	Brush Spring	(2)
10	31-44-1880	Left Handle Half	(1)
11	18-01-0010	Field	(1)
12	16-01-0010	Armature	(1)
13	22-84-0830	Fan Assembly	(1)
14	06-82-7261	6-19 x 11/16" Pan Hd. Slit. Plast. T-20	(1)
15	02-04-0848	Ball Bearing	(1)
16	45-88-0355	Fiber Washer	(1)
17	28-28-1980	Diaphragm Assembly	(1)
18	06-42-0400	Woodruff Key	(1)
19	02-50-1611	Needle Bearing	(1)
20	06-65-0800	Groove Pin	(1)
21	02-50-1640	Needle Bearing	(1)
22	43-44-0900	Gasket	(1)
23	45-88-7721	Thrust Washer	(1)
24	32-40-2260	Intermediate Gear	(1)
25	36-66-4360	Intermediate Pinion Shaft	(1)
26	32-75-3175	Spindle Gear	(1)
27	45-88-0940	Overlap Wave Washer	(1)
28	28-14-2100	Gear Case	(1)
29	02-04-0640	Ball Bearing	(1)
30	02-02-0180	3/16" Steel Ball	(6)
31	44-84-0240	Fixed Ratchet	(1)
32	45-36-1225	Bearing Spacer	(1)
33	44-84-0235	Rotating Ratchet	(1)
34	45-36-1215	Shift Spacer	(1)
35	02-02-0120	1/8" Steel Ball	(15)
36	45-88-0935	Thrust Washer	(1)
37	34-60-0920	Retaining Ring	(1)
38	02-08-0510	Ball Bearing	(1)

FIG.	PART NO.	DESCRIPTION OF PART	NO. REQ.
39	40-50-0220	Compression Spring	(1)
40	38-50-5515	Spindle	(1)
41	34-80-2020	Internal Retaining Ring	(1)
42	34-40-4040	O-Ring	(1)
43	31-58-0055	Locking Collar	(1)
44	34-40-1500	O-Ring	(1)
45	34-60-2125	Retaining Ring	(1)
46	45-12-0520	Hammer Dust Shield	(1)
47	48-66-0400	3/8" Chuck	(1)
48	45-04-0750	Chuck Screw	(1)
49	43-62-0905	Side Handle	(1)
50	45-36-1255	Flanged Spacer	(1)
51	06-82-7393	7-18 x 2" Pan Hd. Slit. Plast. T-20	(3)
52	02-04-5130	Ball Bearing	(1)
53	—	12.0 V. Battery Pack-Select From Cat.	(1)
54	22-32-0400	Brush Spring Clip	(2)
55	44-66-6140	Mounting Plate	(1)
56	45-88-5615	Wave Spring Washer	(1)

FIG. NOTES

- 1 Torque to 15-20 In./Lbs.
- 4,7,8 Slot on brush tube must be assembled on the same side as slot on motor housing. Brush assemblies must be inserted with the wire laying inside of brush tube slot. Brush must slide freely inside brush tube.
- 7,54 Brush spring clip must snap into detent of brush tube.
- 14 Torque field screw to 15-20 In./Lbs.
- 15 Press flush to casting surface. Seal towards armature.
- 19 Press only on end with manufacturer ID.
- 19,21 Press flush to casting surface.
- 48 Apply type 242 blue locite and torque to 40-45 in./lbs.
- 51 Torque gear case screws to 30-38 In./Lbs.

FIG. LUBRICATION

- 28 1/2 oz. type "K" grease, No. 49-08-4161.
- 31,33 1/2 tsp. type "K" grease, No. 49-08-4161.
- 34,35 1/4 tsp. type "K" grease, No. 49-08-4161.
- 42,44 Coat with type "K" grease, No. 49-08-4161.

MILWAUKEE ELECTRIC TOOL CORPORATION
13135 W. LISBON RD., BROOKFIELD, WI 53005