



SERVICE PARTS LIST

BULLETIN NO.
55-06-1751

SPECIFY CATALOG NO. AND SERIAL NO. WHEN ORDERING PARTS		REVISED BULLETIN	DATE
VARIABLE SPEED 3/8" CORDLESS DRIVER/DRILL		55-06-1750	Aug.'93
CATALOG NO. 0398-4	STARTING SERIAL NO. 778A	WIRING INSTRUCTION 58-01-1240	

EXAMPLE:
Component Parts (Small #)
Are Included When Ordering
The Assembly (Large #).

00 0

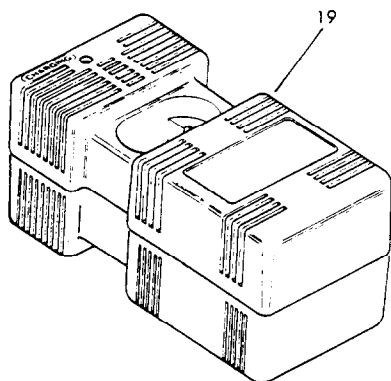
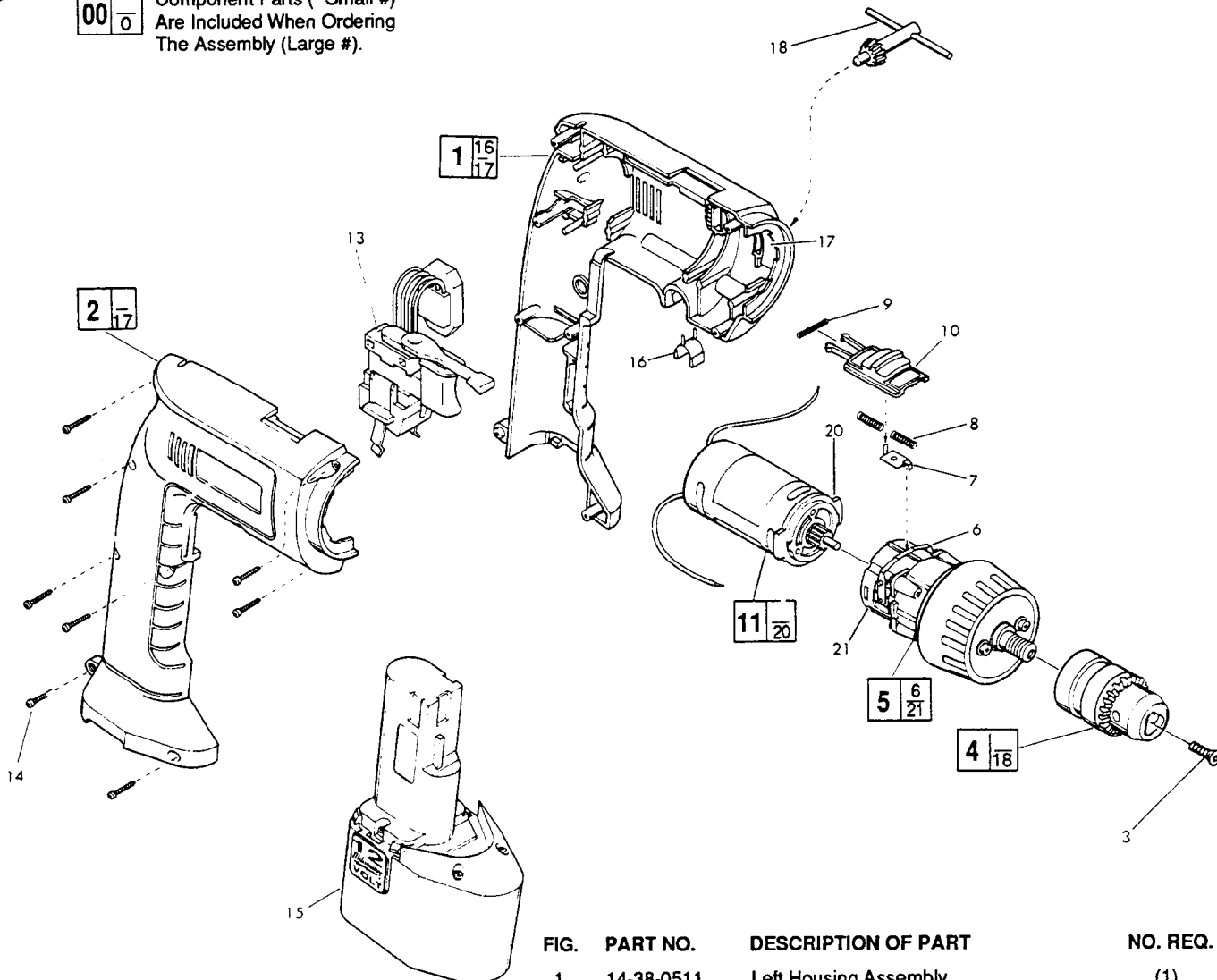

FIG.	PART NO.	DESCRIPTION OF PART	NO. REQ.
1	14-38-0511	Left Housing Assembly	(1)
2	14-38-0530	Right Housing Assembly	(1)
★ 3	05-88-1399	Chuck Retaining Screw T-20	(1)
4	48-66-0817	Chuck	(1)
5	14-30-0720	Gear Box Assembly	(1)
★ 6	44-10-0280	Change Gear Lever	(1)
7	44-14-0160	Link	(1)
8	40-50-8300	Spring	(2)
9	40-50-8310	Spring	(1)
10	45-24-0070	Slide - High/Low	(1)
11	14-50-0620	Motor Assembly	(1)
★ 13	23-66-2210	Variable Speed Switch	(1)
14	06-82-7236	4-20x5/8" Plastite Pan Hd. T-10	(8)
15	48-11-0140	12.0 V. Battery Pack	(1)
16	42-70-0260	Clip-Chuck Key	(1)
17	44-52-0440	Foam Pad	(2)
18	48-66-3350	Chuck Key	(1)
19	48-59-0035	Battery Charger	(1)
★ 20	44-66-0850	Motor Mount Plate	(1)
★ 21	31-50-0770	Gear Housing	(1)