



SERVICE PARTS LIST

BULLETIN NO.
55-06-1853

SPECIFY CATALOG NO. AND SERIAL NO. WHEN ORDERING PARTS		REVISED BULLETIN	DATE
VARIABLE SPEED 3/8" CORDLESS DRIVER/DRILL		55-06-1852	Feb. '96
CATALOG NO.	0396-4	WIRING INSTRUCTION	
STARTING SERIAL NO.	783C	58-01-1241	

EXAMPLE:



Component Parts (Small #)
Are Included When Ordering
The Assembly (Large #).

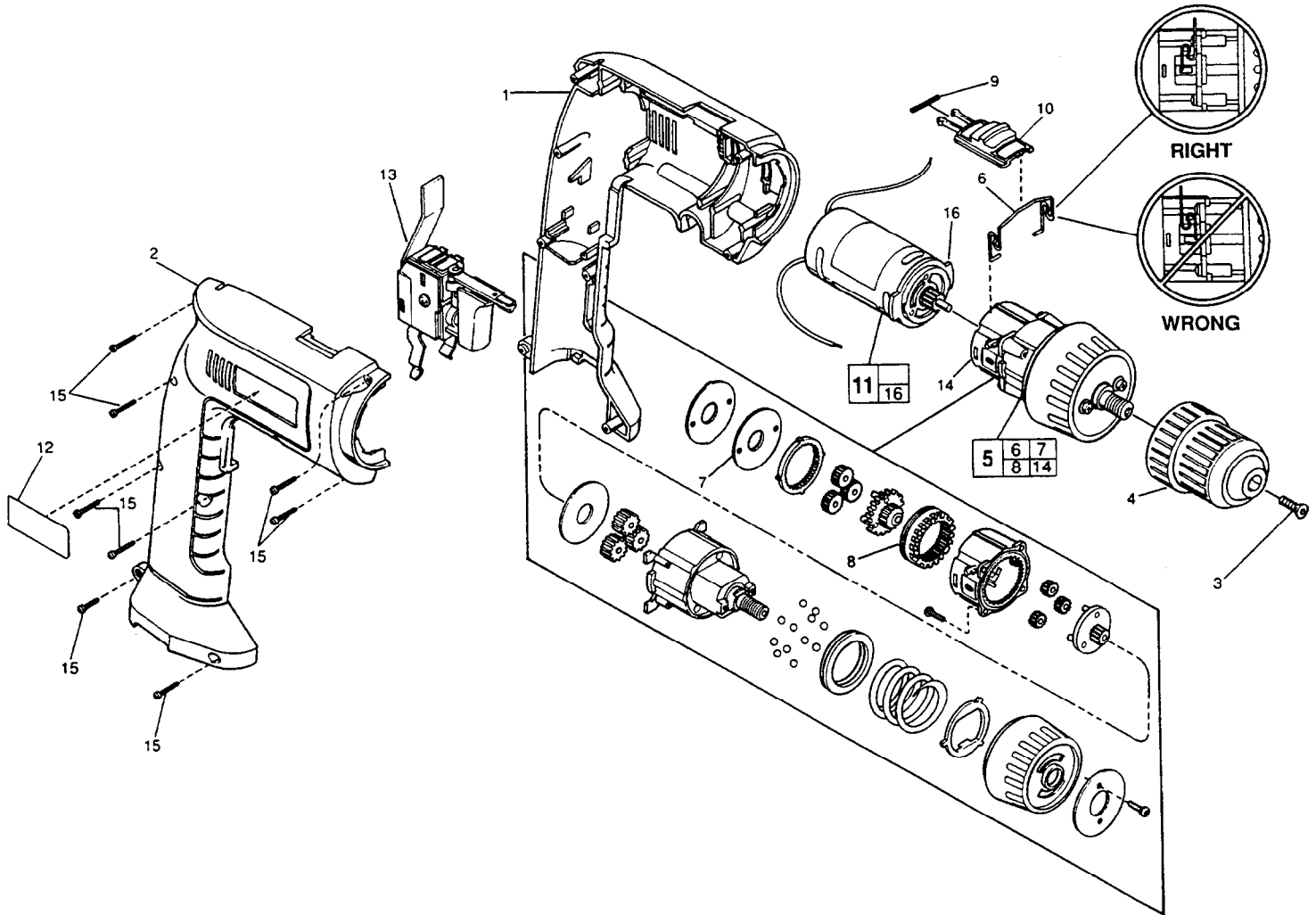

FIG.	PART NO.	DESCRIPTION OF PART	NO. REQ.
★ 1	31-50-1065	Left Housing Half	(1)
★ 2	31-50-1075	Right Housing Half	(1)
3	05-88-1399	Chuck Retaining Screw T-20	(1)
4	48-66-0375	Chuck	(1)
★ 5	14-30-0726	Gear Box Assembly	(1)
★ 6	44-10-0390	Shift Lever	(1)
7	45-88-8590	Thrust Washer	(1)
8	32-65-0050	Shift Lever Ring Gear	(1)
9	40-50-8310	Spring	(1)
★ 10	45-24-0075	Slide - High/Low	(1)
11	14-50-0620	Motor Assembly	(1)
12	12-20-0360	Service Nameplate Kit	(1)
13	23-66-2300	Variable Speed Switch	(1)
14	31-50-0770	Gear Housing	(1)
15	06-82-7236	4-20 x 5/8" Plastite Pan Hd. Torx T-10	(8)
16	44-66-0850	Motor Mount Plate	(1)

MILWAUKEE ELECTRIC TOOL CORPORATION
13135 W. LISBON RD., BROOKFIELD, WI 53005