

SERVICE PARTS LIST

BULLETIN NO.
55-06-1653

SPECIFY CATALOG NO. AND SERIAL NO. WHEN ORDERING PARTS		REVISED BULLETIN 55-06-1652	DATE Feb. '96
VARIABLE SPEED 3/8" CORDLESS DRIVER/DRILL			
CATALOG NO.	0394-4	STARTING SERIAL NO.	765C
		WIRING INSTRUCTION 58-01-1241	

EXAMPLE:
Component Parts (Small #)
Are Included When Ordering
The Assembly (Large #).

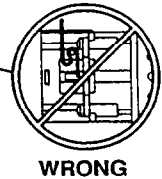
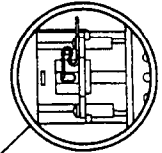
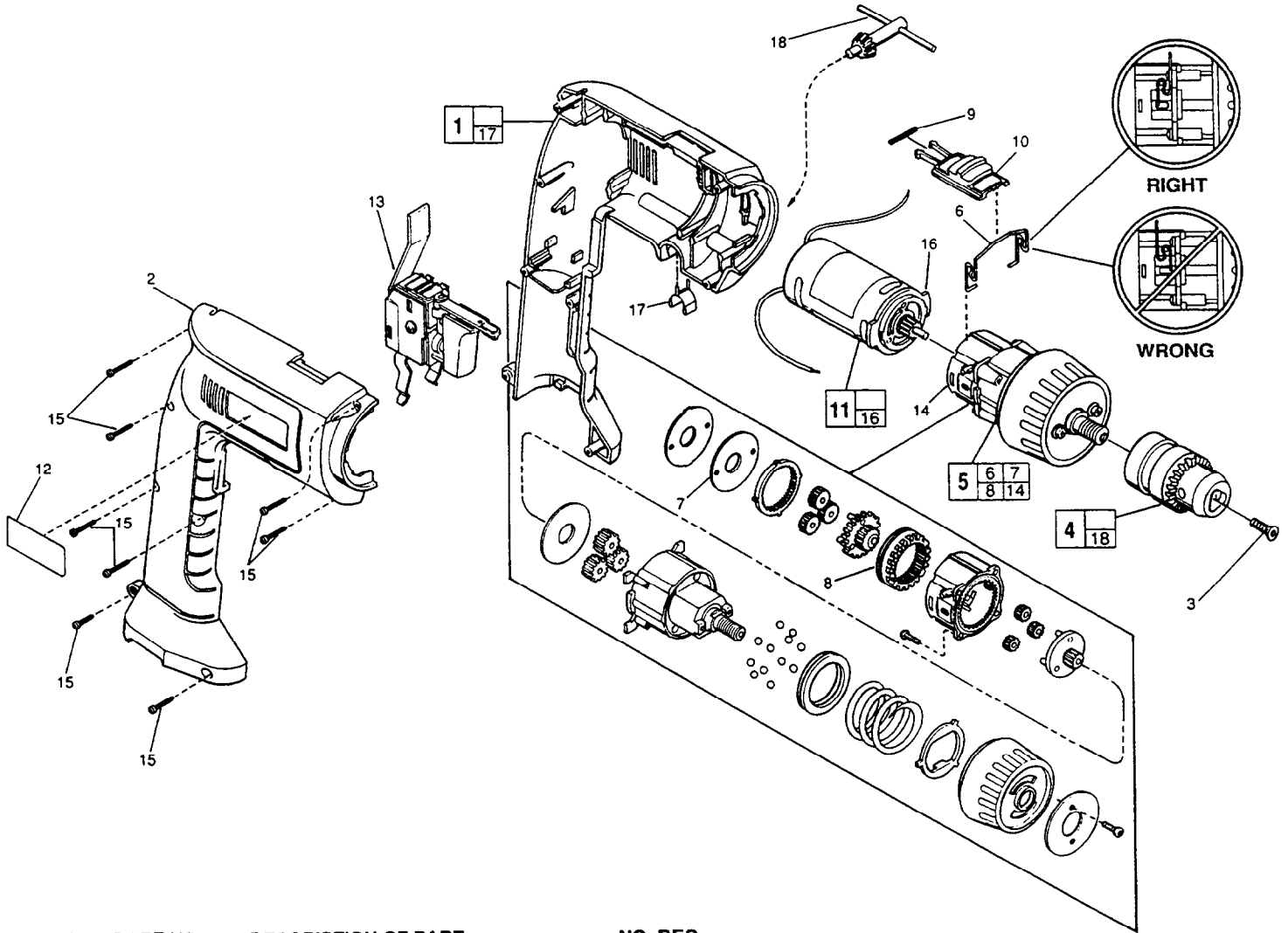

FIG.	PART NO.	DESCRIPTION OF PART	NO. REQ.
1	14-38-0630	Left Housing Assembly	(1)
★ 2	31-50-1075	Right Housing Half	(1)
3	05-88-1399	Chuck Retaining Screw T-20	(1)
4	48-66-0817	Chuck	(1)
★ 5	14-30-0726	Gear Box Assembly	(1)
★ 6	44-10-0390	Shift Lever	(1)
7	45-88-8590	Thrust Washer	(1)
8	32-65-0050	Shift Lever Ring Gear	(1)
9	40-50-8310	Spring	(1)
★ 10	45-24-0075	Slide - High/Low	(1)
11	14-50-0610	Motor Assembly	(1)
12	12-20-0340	Service Nameplate Kit	(1)
13	23-66-2300	Variable Speed Switch	(1)
14	31-50-0770	Gear Housing	(1)
15	06-82-7236	4-20 x 5/8" Plastite Pan Hd. Torx T-10	(8)
16	44-66-0850	Motor Mount Plate	(1)
17	42-70-0260	Clip - Chuck Key	(1)
18	48-66-3350	Chuck Key	(1)