



# SERVICE PARTS LIST

**BULLETIN NO.**  
**54-06-0853**

SPECIFY CATALOG NO. AND SERIAL NO. WHEN ORDERING PARTS		REVISED BULLETIN 54-06-0852	DATE Dec.'90
<b>1/2" KEYLESS CHUCK MAGNUM DRILL</b>			
CATALOG NO. <b>0235-1</b>	STARTING SERIAL NO. <b>755-24148</b>	WIRING INSTRUCTION <b>58-01-0074</b>	

**EXAMPLE:**  
Component Parts ( Small # )  
Are Included When Ordering  
The Assembly ( Large # ).

00 0

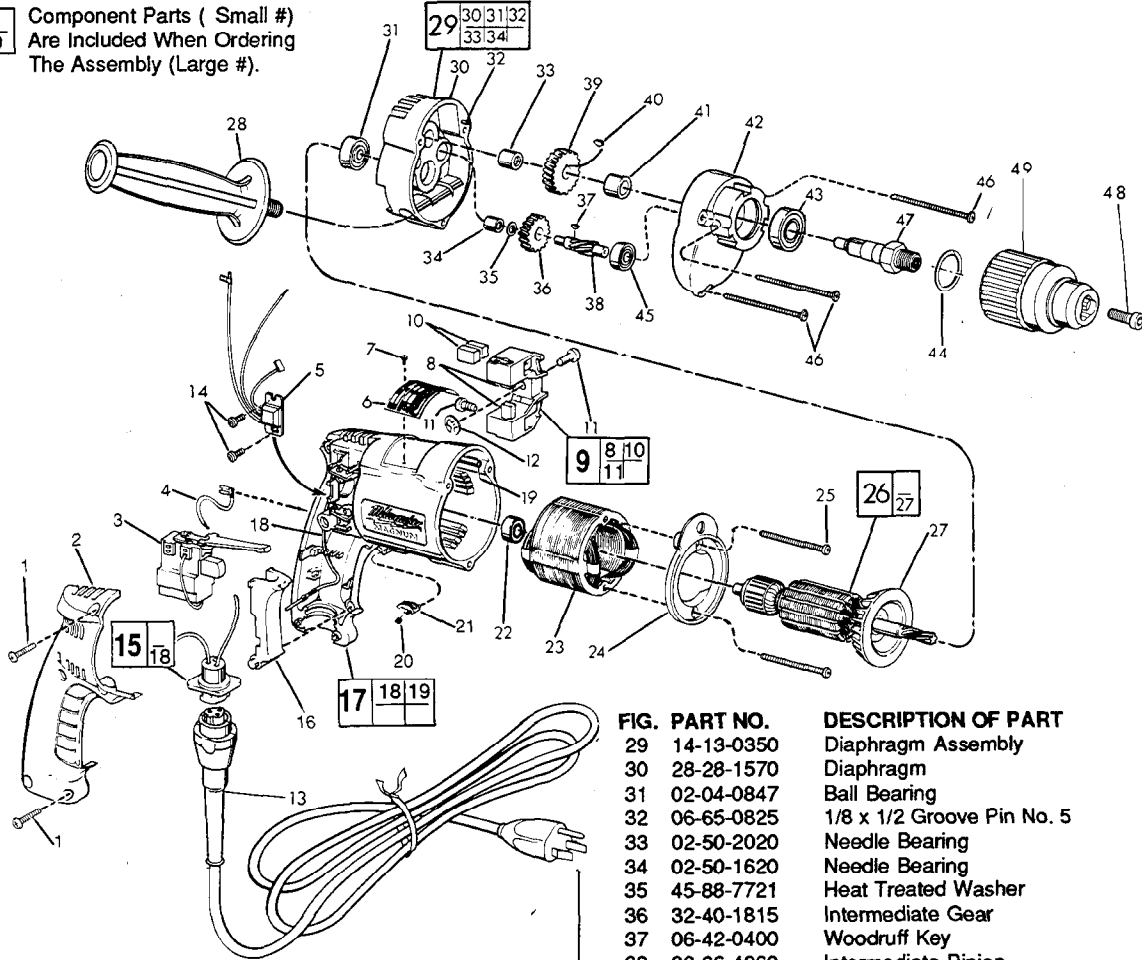

FIG.	PART NO.	DESCRIPTION OF PART	NO. REQ.
1	06-95-0185	7-18x11/16" Pan Hd. Plastite Screw	(5)
2	31-15-0101	Handle Cover	(1)
3	23-66-1665	Trigger Speed Control Switch	(1)
4	23-94-9635	2-1/4" Lead Assembly	(1)
5	14-20-0245	Remote Electronic Assembly	(1)
6	12-99-0071	Nameplate Blank	(1)
7	06-85-0200	Nameplate Screw	(2)
8	22-16-0275	Carbon Brush	(2)
9	22-22-0350	Brush Holder Assembly	(1)
10	22-16-0275	Carbon Brush (Spares)	(2)
11	31-75-0011	Brush Holder Screw	(2)
12	34-60-0500	1/4" Ext. Retaining Ring	(1)
13	48-76-4008	Cord Set	(1)
14	06-82-7212	4-20 x 1/4" Pan Hd. Plastite Torx	(2)
15	22-56-0302	Pin Housing Assembly	(1)
16	45-72-0080	Trigger	(1)
17	14-38-0356	Motor Housing Assembly	(1)
18	23-94-9686	Ground Wire Assembly	(1)
19	44-60-0570	Grounding Pin	(1)
20	40-50-0085	Lock Button Spring	(1)
21	42-42-0150	Lock Button	(1)
22	02-04-0645	Ball Bearing	(1)
23	18-10-0045	120 Volt Field	(1)
24	31-05-0065	Baffle	(1)
25	06-95-0140	7-18x1-7/8" Pan Hd. Screw	(2)
26	16-10-0500	120 Volt Armature Assembly	(1)
27	22-84-0650	Fan	(1)
28	43-62-0885	Side Handle	(1)

FIG.	PART NO.	DESCRIPTION OF PART	NO. REQ.	
29	14-13-0350	Diaphragm Assembly	(1)	
30	28-28-1570	Diaphragm	(1)	
31	02-04-0847	Ball Bearing	(1)	
32	06-65-0825	1/8 x 1/2 Groove Pin No. 5	(1)	
33	02-50-2020	Needle Bearing	(1)	
34	02-50-1620	Needle Bearing	(1)	
35	45-88-7721	Heat Treated Washer	(1)	
36	32-40-1815	Intermediate Gear	(1)	
37	06-42-0400	Woodruff Key	(1)	
38	36-66-4260	Intermediate Pinion	(1)	
39	32-75-2910	Spindle Gear	(1)	
40	06-42-1200	Woodruff Key	(1)	
41	45-36-1100	Spacer	(1)	
42	28-14-1990	Gear Case	(1)	
43	02-04-1230	Ball Bearing	(1)	
44	34-80-2300	Retaining Ring	(1)	
45	02-04-0640	Ball Bearing	(1)	
46	06-95-0150	7-18x2-3/16" Pan Hd. Screw	(3)	
47	38-50-5250	Spindle - Double Reduction	(1)	
48	06-75-3150	1/4-20x1" L.H. Thread Skt. Hd. Screw	(1)	
*	49	48-66-2020	Keyless Chuck	(1)
		10-98-5986	Warning Label	(1)
		10-98-6465	Bi-Lingual Label	(1)

**FIG. LUBRICATION**

42 1.5 Oz. Type "E" Grease, 49-08-4121. Place Grease Near Intermediate Shaft Ball Bearing In Gear Case.

**FIG. NOTES**

47 Apply Blue Loctite To Internal Threads Prior to Chuck Assy.  
49 Hand Tighten Milwaukee Keyless Chuck Onto Spindle. Insert And Hand Tighten Chuck Retaining Screw. Insert Service Fixture 61-30-0155 Into The Chuck And Hand Tighten The Jaws Onto The Fixture. Place Fwd. / Rev. Switch In The Forward Position And Ratchet Chuck For 4 Seconds. Tighten Chuck Retaining Screw To Secure Chuck To Spindle (150 Lb./In.).

**MILWAUKEE ELECTRIC TOOL CORPORATION**  
13135 W. LISBON RD., BROOKFIELD, WI 53005