



SERVICE PARTS LIST

BULLETIN NO.
54-06-1953

SPECIFY CATALOG NO. AND SERIAL NO. WHEN ORDERING PARTS		REVISED BULLETIN	DATE
3/8" KEYLESS CHUCK MAGNUM DRILL		54-06-1952	Mar. '95
CATALOG NO. 0225-1	STARTING SERIAL NO. 796-30768	WIRING INSTRUCTION 58-01-1600	

EXAMPLE:
Component Parts (Small #)
Are Included When Ordering
The Assembly (Large #).

00 0

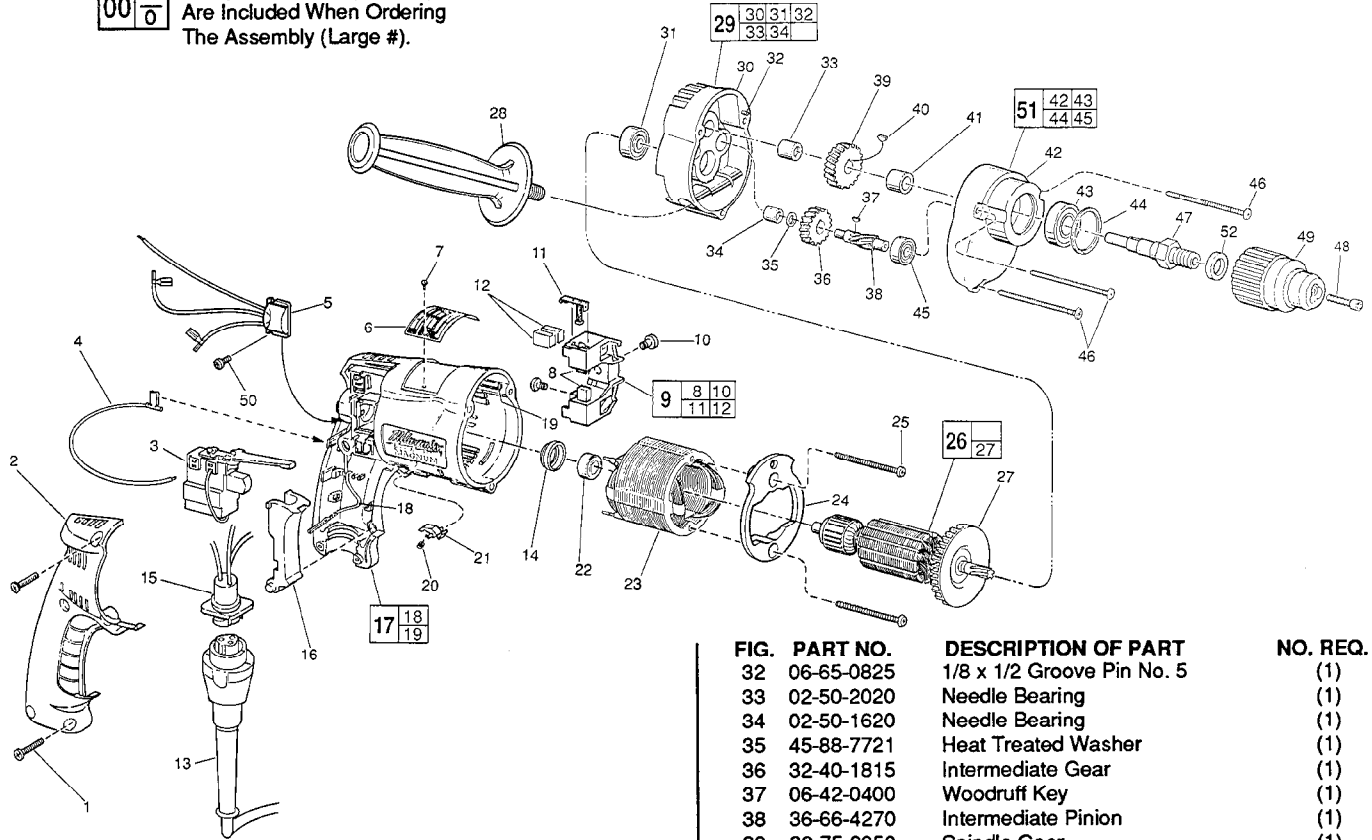

FIG.	PART NO.	DESCRIPTION OF PART	NO. REQ.
	1	06-82-7266 7-18 x 11/16" Pan Hd. Plastite T-20	(5)
★	2	31-15-0402 Handle Cover	(1)
	3	23-66-1665 Trigger Speed Control Switch	(1)
	4	23-94-6245 2-1/4" Lead Assembly	(1)
★	5	14-20-0765 Remote Electronic Assembly	(1)
	6	12-99-0071 Nameplate Blank	(1)
★	7	06-72-1720 Nameplate Rivet	(2)
	8	22-16-0275 Carbon Brush	(2)
	9	22-22-0351 Brush Holder Assembly	(1)
	10	31-75-0040 Brush Holder Screw	(2)
	11	22-20-0345 Brush Spring Assembly	(2)
	12	22-16-0275 Carbon Brush (Spares)	(2)
	13	48-76-4008 Cord Set	(1)
	14	22-72-0100 Bearing Cup	(1)
	15	22-56-0630 Pin Housing Assembly	(1)
	16	45-72-0080 Trigger	(1)
	17	14-38-0540 Motor Housing Assembly	(1)
	18	23-94-9960 Ground Wire Assembly	(1)
	19	44-60-1290 Grounding Pin	(1)
	20	40-50-0085 Lock Button Spring	(1)
★	21	42-42-0460 Lock Button	(1)
	22	02-04-0645 Ball Bearing	(1)
	23	18-11-0075 120 Volt Field	(1)
★	24	42-14-0390 Baffle	(1)
★	25	06-82-7398 7-18 x 2-1/16" Pan Hd. Plastite T-20	(2)
★	26	16-10-0800 120 Volt Armature Assembly	(1)
★	27	22-84-0880 Fan	(1)
	28	43-62-0885 Side Handle	(1)
	29	14-13-0465 Diaphragm Assembly	(1)
	30	Diaphragm	(1)
	31	02-04-0847 Ball Bearing	(1)

FIG.	PART NO.	DESCRIPTION OF PART	NO. REQ.
	32	06-65-0825 1/8 x 1/2 Groove Pin No. 5	(1)
	33	02-50-2020 Needle Bearing	(1)
	34	02-50-1620 Needle Bearing	(1)
	35	45-88-7721 Heat Treated Washer	(1)
	36	32-40-1815 Intermediate Gear	(1)
	37	06-42-0400 Woodruff Key	(1)
	38	36-66-4270 Intermediate Pinion	(1)
	39	32-75-2950 Spindle Gear	(1)
	40	06-42-1200 Woodruff Key	(1)
	41	45-36-1100 Spacer	(1)
	42	28-14-1800 Gear Case	(1)
	43	02-04-1229 Ball Bearing	(1)
	44	34-80-2300 Retaining Ring	(1)
	45	02-04-0640 Ball Bearing	(1)
	46	06-82-7411 7-18 x 2-3/16" Pan Hd. Plastite T-20	(3)
	47	38-50-5266 Spindle - Double Reduction	(1)
★	48	45-04-0755 Chuck Screw	(1)
	49	48-66-2030 Keyless Chuck	(1)
	50	06-82-7212 4-20 x 1/4" Pan Hd. Plastite T-10	(1)
	51	14-30-0335 Gear Case Assembly	(1)
	52	45-88-7940 Chuck Washer	(1)
		10-98-5986 Warning Label	(1)

FIG. LUBRICATION
42 1.5 Oz. Type "E" Grease, 49-08-4122. Place Grease Near Intermediate Shaft Ball Bearing In Gear Case.

FIG. NOTES
47,48,49 New Chuck Screw, No. 06-75-3155, Is Pretreated With Fastener Adhesive. When Replacing Chuck With Existing Chuck Screw: Apply Fastener Adhesive To Chuck Screw Threads And Internal Threads Of Spindle Prior to Chuck Assembly.
49 Hand Tighten Milwaukee Keyless Chuck Onto Spindle. Insert And Hand Tighten Chuck Retaining Screw. Insert Service Fixture 61-30-0155 Into The Chuck And Hand Tighten The Jaws Onto The Fixture. Place Fwd./Rev. Switch In The Forward Position And Ratchet Chuck For 4 Seconds. Tighten Chuck Retaining Screw To Secure Chuck To Spindle (150 Lb./in.).

MILWAUKEE ELECTRIC TOOL CORPORATION
13135 W. LISBON RD., BROOKFIELD, WI 53005