



# SERVICE PARTS LIST

**BULLETIN NO.**  
**54-06-1952**

SPECIFY CATALOG NO. AND SERIAL NO. WHEN ORDERING PARTS		REVISED BULLETIN	DATE
<b>3/8" KEYLESS CHUCK MAGNUM DRILL</b>		54-06-1951	Dec. '92
CATALOG NO. <b>0225-1</b>	STARTING SERIAL NO. <b>796-2656</b>	WIRING INSTRUCTION <b>58-01-0077</b>	

**EXAMPLE:**



Component Parts ( Small #)  
Are Included When Ordering  
The Assembly (Large #).

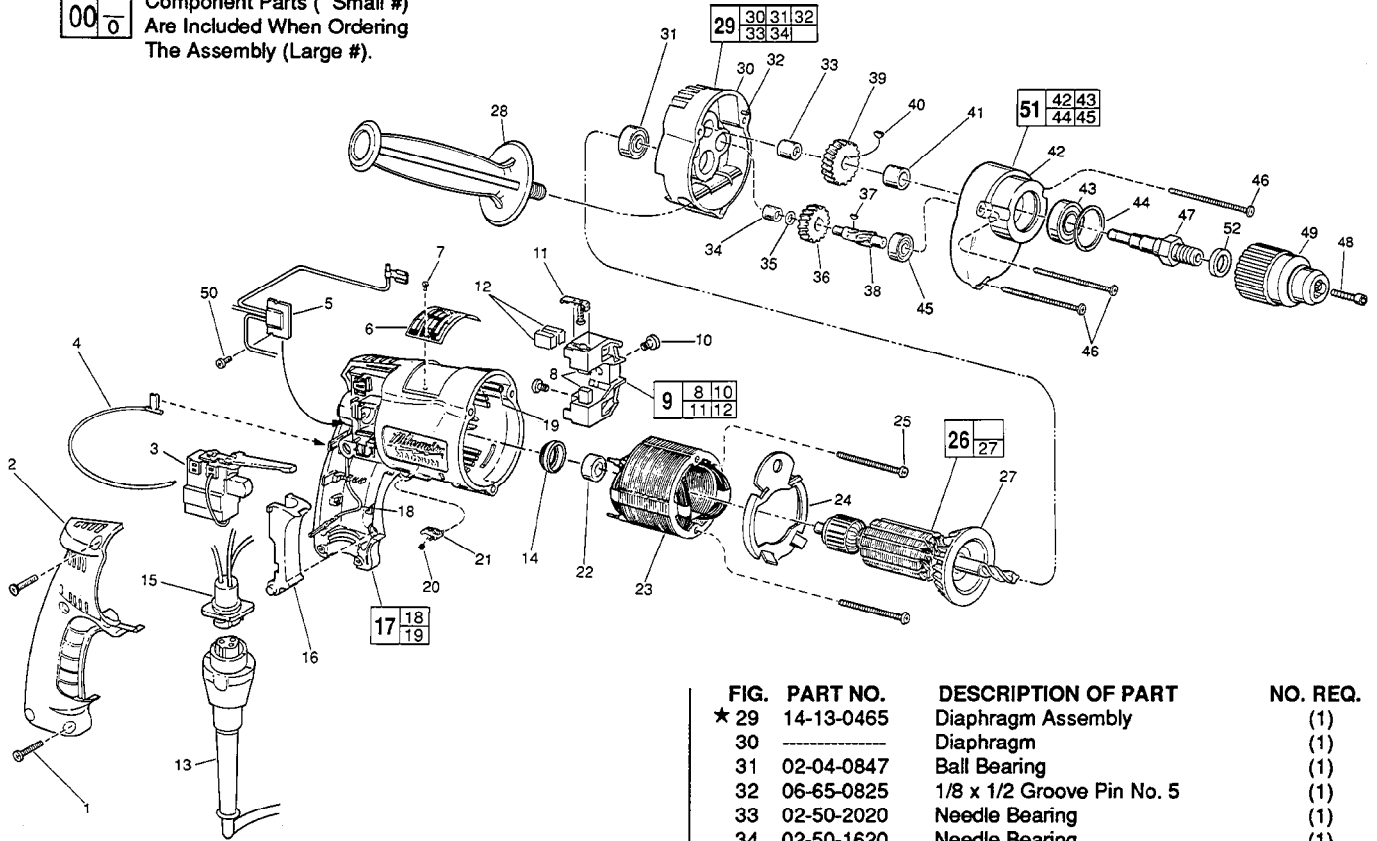

FIG.	PART NO.	DESCRIPTION OF PART	NO. REQ.
1	06-82-7266	7-18x11/16" Pan Hd. Plastite T-20	(5)
2	31-15-0401	Handle Cover	(1)
3	23-66-1665	Trigger Speed Control Switch	(1)
4	23-94-6245	2-1/4" Lead Assembly	(1)
5	14-20-0250	Remote Electronic Assembly	(1)
6	12-99-0071	Nameplate Blank	(1)
7	06-85-0200	Nameplate Screw	(2)
8	22-16-0275	Carbon Brush	(2)
9	22-22-0351	Brush Holder Assembly	(1)
10	31-75-0040	Brush Holder Screw	(2)
11	22-20-0345	Brush Spring Assembly	(2)
12	22-16-0275	Carbon Brush (Spares)	(2)
13	48-76-4008	Cord Set	(1)
14	22-72-0100	Bearing Cup	(1)
15	22-56-0630	Pin Housing Assembly	(1)
16	45-72-0080	Trigger	(1)
17	14-38-0540	Motor Housing Assembly	(1)
18	23-94-9960	Ground Wire Assembly	(1)
19	44-60-1290	Grounding Pin	(1)
20	40-50-0085	Lock Button Spring	(1)
21	42-42-0150	Lock Button	(1)
22	02-04-0645	Ball Bearing	(1)
23	18-11-0075	120 Volt Field	(1)
24	42-14-0345	Baffle	(1)
25	06-82-7393	7-18x2" Pan Hd. Plastite T-20	(2)
26	16-10-0500	120 Volt Armature Assembly	(1)
27	22-84-0650	Fan	(1)
28	43-62-0885	Side Handle	(1)

FIG.	PART NO.	DESCRIPTION OF PART	NO. REQ.
★ 29	14-13-0465	Diaphragm Assembly	(1)
30		Diaphragm	(1)
31	02-04-0847	Ball Bearing	(1)
32	06-65-0825	1/8 x 1/2 Groove Pin No. 5	(1)
33	02-50-2020	Needle Bearing	(1)
34	02-50-1620	Needle Bearing	(1)
35	45-88-7721	Heat Treated Washer	(1)
36	32-40-1815	Intermediate Gear	(1)
37	06-42-0400	Woodruff Key	(1)
38	36-66-4270	Intermediate Pinion	(1)
39	32-75-2950	Spindle Gear	(1)
40	06-42-1200	Woodruff Key	(1)
41	45-36-1100	Spacer	(1)
42	28-14-1800	Gear Case	(1)
43	02-04-1229	Ball Bearing	(1)
44	34-80-2300	Retaining Ring	(1)
45	02-04-0640	Ball Bearing	(1)
46	06-82-7411	7-18x2-3/16" Pan Hd. Plastite T-20	(3)
47	38-50-5266	Spindle - Double Reduction	(1)
48	45-04-0750	Chuck Screw	(1)
49	48-66-2030	Keyless Chuck	(1)
50	06-82-7212	4-20 x 1/4" Pan Hd. Plastite T-10	(1)
51	14-30-0335	Gear Case Assembly	(1)
52	45-88-7940	Chuck Washer	(1)
	10-98-5986	Warning Label	(1)

**FIG. LUBRICATION**

42 1.5 Oz. Type "E" Grease, 49-08-4122. Place Grease Near Intermediate Shaft Ball Bearing In Gear Case.

**FIG. NOTES**

- 47 Apply Blue Loctite To Internal Threads Prior to Chuck Assy.
- 49 Hand Tighten Milwaukee Keyless Chuck Onto Spindle. Insert And Hand Tighten Chuck Retaining Screw. Insert Service Fixture 61-30-0155 Into The Chuck And Hand Tighten The Jaws Onto The Fixture. Place Fwd. / Rev. Switch In The Forward Position And Ratchet Chuck For 4 Seconds. Tighten Chuck Retaining Screw To Secure Chuck To Spindle (150 Lb./In.).

**MILWAUKEE ELECTRIC TOOL CORPORATION**  
13135 W. LISBON RD., BROOKFIELD, WI 53005