



SERVICE PARTS LIST

BULLETIN NO.
54-06-0671

SPECIFY CATALOG NO. AND SERIAL NO. WHEN ORDERING PARTS		REVISED BULLETIN 54-06-0670	DATE Aug. '99
1/4" T.S.C. REV. HOLE-SHOOTER			
CATALOG NO. 0141-1	STARTING SERIAL NO. 708-5701	WIRING INSTRUCTION 58-01-0019	

EXAMPLE:
Component Parts (Small #)
Are Included When Ordering
The Assembly (Large #).

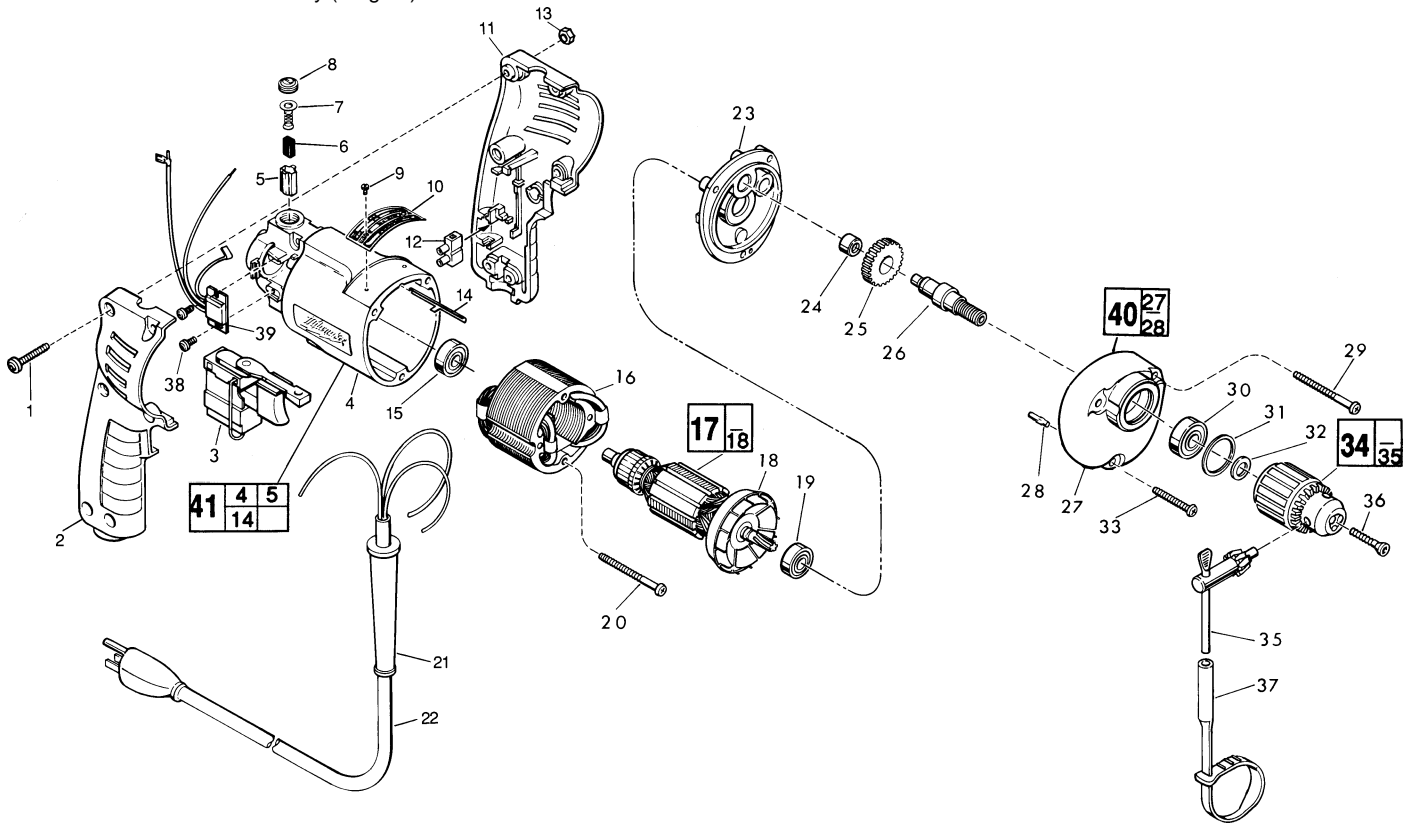

FIG.	PART NO.	DESCRIPTION OF PART	NO. REQ.
★	1	06-82-2361 8-32 x 15/16" Pan Hd. Slit. Plast. T-20	(6)
	2	31-44-1130 Right Handle Half	(1)
★	3	23-66-1655 Speed Control Switch	(1)
★	4	31-50-0346 Motor Housing	(1)
	5	22-20-0530 Brush Tube	(2)
	6	22-16-0275 Carbon Brush	(2)
	7	23-52-0210 Brush Spring Assembly	(2)
	8	23-44-0120 Brush Retaining Screw	(2)
	9	06-85-0200 Nameplate Screw	(2)
	10	12-99-0420 Service Nameplate	(1)
	11	31-44-1140 Left Handle Half	(1)
★	12	22-56-0456 Terminal Block	(1)
	13	06-55-0835 8-32 Hex Nut	(6)
	14	44-60-0530 Ground Pin	(1)
	15	02-04-0645 Ball Bearing	(1)
	16	18-11-0060 120 Volt Field	(1)
	17	16-10-0460 120 Volt Armature	(1)
	18	22-84-0760 Fan Assembly	(1)
	19	02-04-0847 Ball Bearing	(1)
★	20	06-82-7368 7-18 x 1-3/4" Pan Hd. Slit. Plast. T-20	(2)
	21	44-76-0130 Cord Protector	(1)
	22	22-64-1120 Cord Set	(1)
	23	28-28-1780 Diaphragm	(1)
	24	02-50-1620 Needle Bearing	(1)
	25	32-75-3250 Spindle Gear	(1)
	26	38-50-5670 Spindle	(1)
	27	28-14-1830 Gear Case	(1)
	28	06-65-0825 1/8 x 1/2" Groove Pin 5	(1)
★	29	06-82-7344 7-18 x 1-1/2" Pan Hd. Slit. Plast. T-20	(2)

FIG.	PART NO.	DESCRIPTION OF PART	NO. REQ.
	30	02-04-1020 Ball Bearing	(1)
	31	34-80-1400 Retaining Ring	(1)
	32	45-88-7940 Chuck Washer	(1)
★	33	06-82-7308 7-18 x 1-1/8" Pan Hd. Slit. Plast. T-20	(1)
	34	48-66-0070 1/4" Chuck	(1)
	35	48-66-3200 Chuck Key	(1)
	36	45-04-0750 Chuck Screw-L.H. Thread	(1)
	37	48-66-4080 Key Holder	(1)
★	38	06-82-7212 4-20 x 1/4" Pan Hd. Plast. T-10	(1)
★	39	14-20-0240 Remote Electronic Assembly	(1)
★	40	14-30-0610 Gear Case Assembly	(1)
★	41	14-38-0375 Motor Housing Assembly	(1)

FIG. LUBRICATION
27, 40 1-1/8 Oz. Type "E" Grease, No. 49-08-4122.
Place In Center Of Gear Case.

FIG. NOTES
1 Torque to 18- 28 In./Lbs.
20, 29, 33 Torque to 15-20 In./Lbs.
36 Torque to 30-50 In./Lbs.
38 Torque to 3-5 In./Lbs.
24 Press flush to casting surface.
15,19 Seal towards armature.
30 Seal towards chuck.

MILWAUKEE ELECTRIC TOOL CORPORATION
13135 W. LISBON RD., BROOKFIELD, WI 53005
Drwg. 1