



SERVICE PARTS LIST

BULLETIN NO.
54-06-0822

SPECIFY CATALOG NO. AND SERIAL NO. WHEN ORDERING PARTS		REVISED BULLETIN 54-06-0821	DATE May '85
1/4" SINGLE SPEED PISTOL DRILL			
CATALOG NO. 0141	STARTING SERIAL NO. 479-9200	WIRING INSTRUCTION 58-01-0648	
CAT. NO. 0141-6	START SER. NO. 479-9200	BILINGUAL LABEL 10-98-6405	

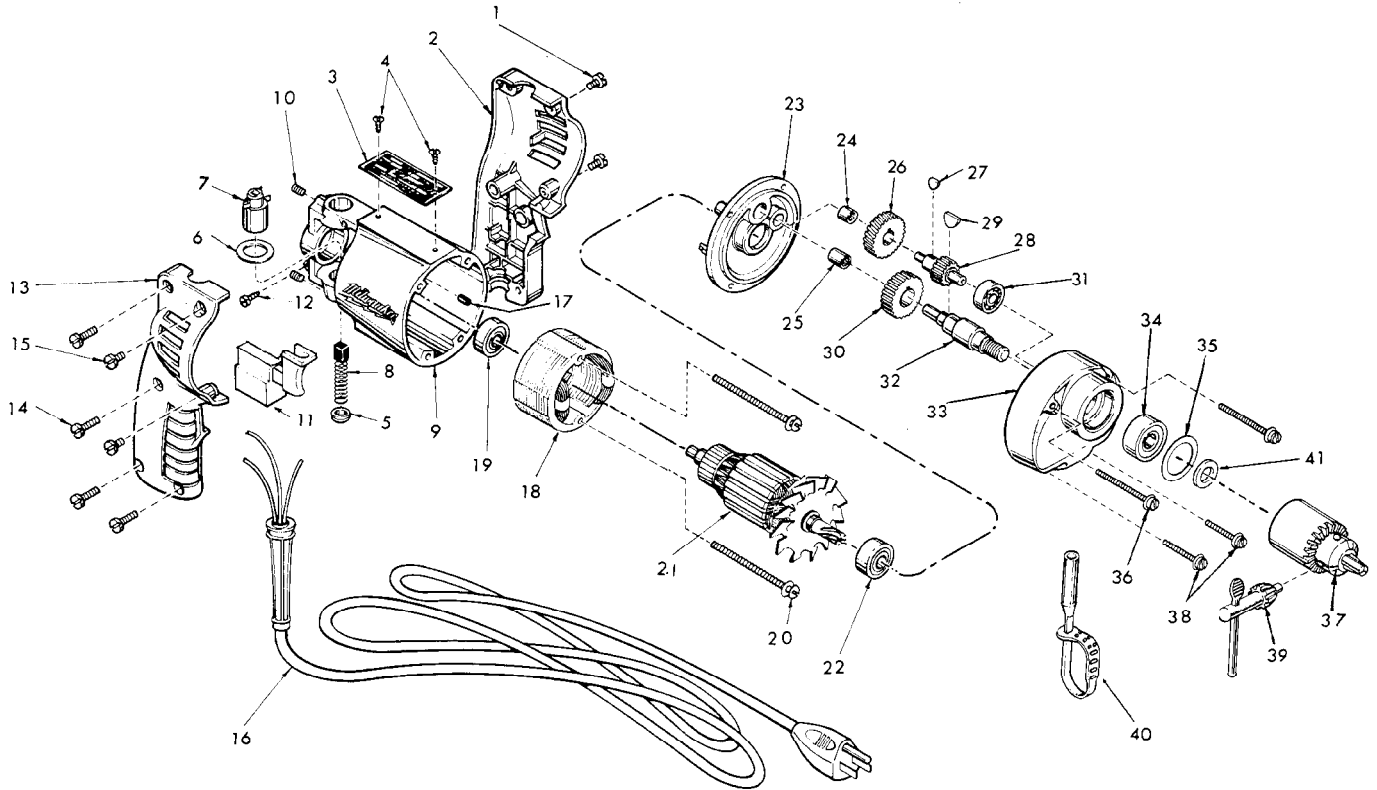

FIG.	PART NO.	DESCRIPTION OF PART	NO. REQ.	FIG.	PART NO.	DESCRIPTION OF PART	NO. REQ.
★ 1	06-95-0209	8-32 x 3/8 Taptite Screw	(2)	22	02-04-0880	Ball Bearing	(1)
★ 2	31-44-1355	L.H. Handle Half	(1)	23	28-28-0221	Diaphragm	(1)
★ 3	12-99-0027	Nameplate Blank	(1)	24	02-50-1210	Needle Bearing	(1)
4	06-85-0200	Nameplate Screw	(2)	25	02-50-1640	Needle Bearing	(1)
5	23-44-0020	Brush Retaining Cap	(2)	26	32-40-1041	Intermediate Gear	(1)
6	23-86-0105	Insulating Washer	(2)	27	06-42-0400	Woodruff Key	(1)
7	22-22-1251	Brush Holder Assy.	(2)	28	36-66-1351	Intermediate Pinion Shaft	(1)
★ 8	22-18-0362	Carbon Brush Assy.	(2)	29	06-42-0800	Woodruff Key	(1)
★ 9	28-50-6096	Motor Housing (Incl. Fig. No. 17)	(1)	30	32-75-1281	Spindle Gear	(1)
10	06-83-2430	10-32x1/4 Soc. Hd. Set Screw	(2)	31	02-04-0640	Ball Bearing	(1)
11	23-66-0515	Switch	(1)	32	38-50-1051	Spindle	(1)
12	06-81-8625	Ground Screw	(1)	33	28-14-0363	Gear Case Assy.	(1)
★ 13	31-44-1360	R.H. Handle Half	(1)	34	02-04-1020	Ball Bearing	(1)
★ 14	06-95-0220	8-18x3/4 Thread Form Screw	(4)	35	34-80-1400	Retaining Ring	(1)
★ 15	06-95-0209	8-32 x 3/8 Taptite Screw	(2)	36	06-81-6575	8-32x1-5/8 Fil. Hd. Sems	(2)
16	22-64-0665	Cord Set	(1)	37	48-66-0260	Chuck	(1)
17	45-30-0120	Ball Bearing Ret. Slug	(1)	38	06-81-6350	8-32x1 Fil. Hd. Sems	(2)
18	18-10-0050	Field	(1)	39	48-66-3200	Chuck Key	(1)
19	02-04-0740	Ball Bearing	(1)	40	48-66-4080	Key Holder	(1)
20	06-81-5935	6-32x1-3/4 Fil. Hd. Screw	(2)	41	45-88-0080	Chuck Washer	(1)
★ 21	16-10-0610	Armature Assy.	(1)	★ 42	10-98-5986	Warning Label (Not Shown) Omit For Canadian Tools	(1)