



SERVICE PARTS LIST

BULLETIN NO.
54-06-2826

SPECIFY CATALOG NO. AND SERIAL NO. WHEN ORDERING PARTS			REVISED BULLETIN 54-06-2825	DATE Mar. 2008
1/4 INCH DRILL				
CATALOG NO.	0101-20	STARTING SERIAL NO.	064B	
			WIRING INSTRUCTION 58-01-1800	

★ = Part number change from previous service parts list.

EXAMPLE:
Component Parts (Small #) Are Included When Ordering The Assembly (Large #).

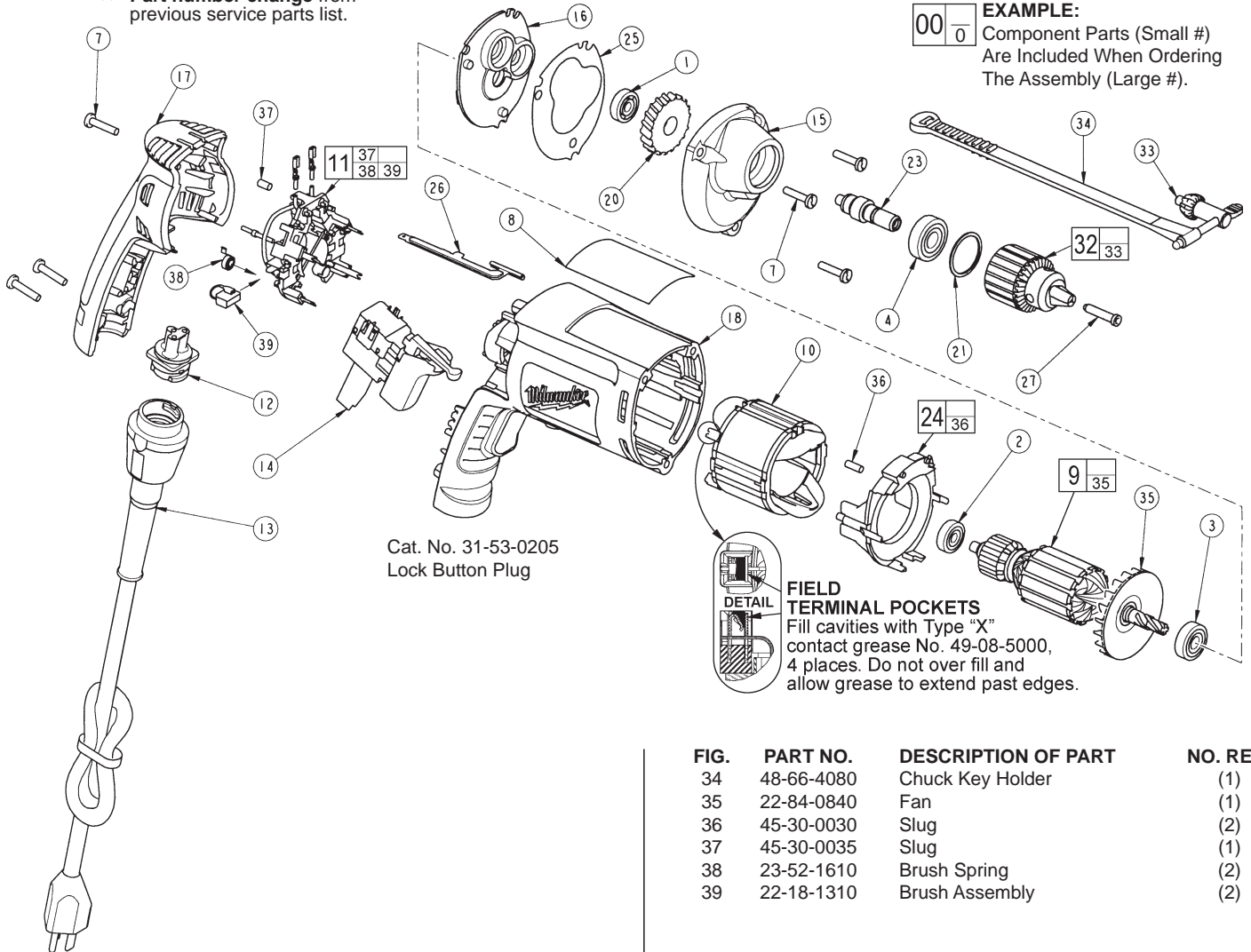

Cat. No. 31-53-0205
Lock Button Plug

FIG.	PART NO.	DESCRIPTION OF PART	NO. REQ.
	34	48-66-4080 Chuck Key Holder	(1)
	35	22-84-0840 Fan	(1)
	36	45-30-0030 Slug	(2)
	37	45-30-0035 Slug	(1)
	38	23-52-1610 Brush Spring	(2)
	39	22-18-1310 Brush Assembly	(2)

LUBRICATION (Type "Y" Grease, No. 49-08-5270)

Place 6.8 gm. (.24 oz.) of grease at the armature pinion location in the gearcase pocket (15) and fill to next higher gearcase level.

Before assembly, lightly coat all press fit areas with lightweight spindle oil.

FIG.	PART NO.	DESCRIPTION OF PART	NO. REQ.
	1	02-04-0640 Ball Bearing	(1)
	2	02-04-0645 Ball Bearing	(1)
	3	02-04-0852 Ball Bearing	(1)
★	4	02-04-1019 Ball Bearing	(1)
	7	06-82-7275 7-18 x 3/4 Slotted Plastite T-20	(6)
	8	12-99-2565 Service Nameplate	(1)
★	9	16-10-2201 Armature	(1)
	10	18-07-2200 Field	(1)
	11	22-18-1210 Brush Card Assembly	(1)
	12	22-56-1010 Pin Housing Assembly	(1)
	13	48-76-4008 Quik-Lok Cord Set	(1)
	14	23-66-2585 Switch	(1)
	15	28-14-2385 Gearcase	(1)
	16	28-28-2315 Diaphragm	(1)
	17	31-15-2030 Handle Halve	(1)
★	18	31-50-2040 Motor Housing	(1)
★	20	32-75-0121 Spindle Gear	(1)
	21	34-80-1400 Retaining Ring	(1)
	23	38-50-5745 Spindle	(1)
	24	42-14-0460 Baffle Assembly	(1)
	25	43-44-0985 Gasket	(1)
	26	44-60-1700 Ground Pin	(1)
	27	45-04-0750 Chuck Screw	(1)
	32	48-66-0070 1/4 Chuck	(1)
	33	48-66-3200 Chuck Key	(1)