

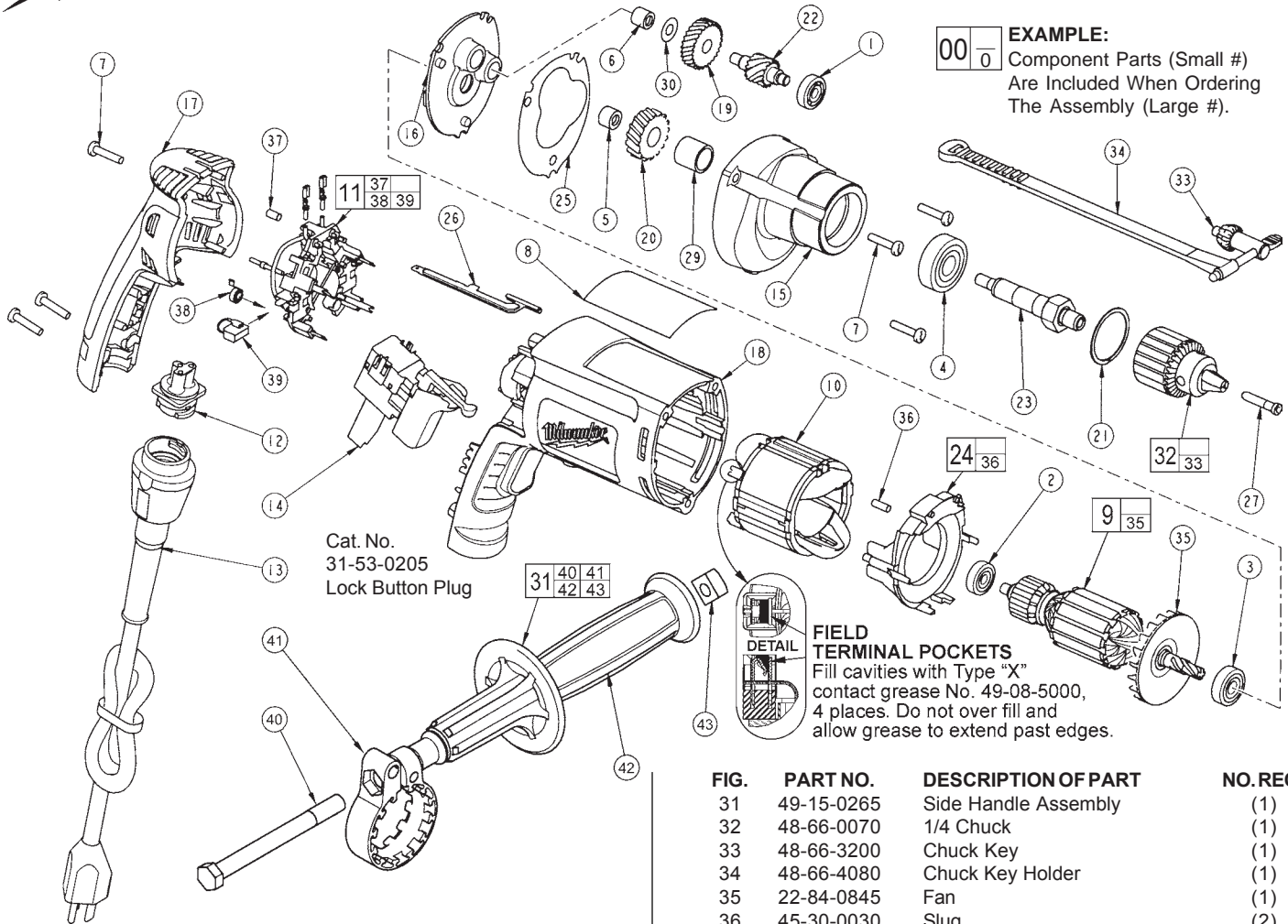

SERVICE PARTS LIST

BULLETIN NO.
54-06-2800

SPECIFY CATALOG NO. AND SERIAL NO. WHEN ORDERING PARTS		REVISED BULLETIN	DATE
1/4 INCH DRILL			Jan. 2003
CATALOG NO. 0100-20	STARTING SERIAL NO. 058A	WIRING INSTRUCTION 58-01-1805	



EXAMPLE:

00	0
----	---

 Component Parts (Small #)
 Are Included When Ordering
 The Assembly (Large #).

Cat. No.
31-53-0205
Lock Button Plug

FIELD TERMINAL POCKETS
 Fill cavities with Type "X"
 contact grease No. 49-08-5000,
 4 places. Do not over fill and
 allow grease to extend past edges.

FIG.	PART NO.	DESCRIPTION OF PART	NO. REQ.
1	02-04-0640	Ball Bearing	(1)
2	02-04-0645	Ball Bearing	(1)
3	02-04-0852	Ball Bearing	(1)
4	02-04-1229	Ball Bearing	(1)
5	02-50-1611	Needle Bearing	(1)
6	02-50-2400	Needle Bearing	(1)
7	06-82-7275	7-18 x 3/4 Slotted Plastite T-20	(6)
8	12-99-2565	Service Nameplate	(1)
9	16-10-2215	Armature	(1)
10	18-07-2200	Field	(1)
11	22-18-1210	Brush Card Assembly	(1)
12	22-56-1010	Pin Housing Assembly	(1)
13	48-76-4008	Quik-Lok Cord Set	(1)
14	23-66-2585	Switch	(1)
15	28-14-2390	Gearcase	(1)
16	28-28-2320	Diaphragm	(1)
17	31-15-2030	Handle Halve	(1)
18	31-50-2040	Motor Housing	(1)
19	32-40-0100	Intermediate Gear	(1)
20	32-75-0115	Spindle Gear	(1)
21	34-80-2300	Retaining Ring	(1)
22	36-66-0125	Intermediate Shaft	(1)
23	38-50-5750	Spindle	(1)
24	42-14-0460	Baffle Assembly	(1)
25	43-44-0985	Gasket	(1)
26	44-60-1700	Ground Pin	(1)
27	45-04-0750	Chuck Screw	(1)
29	45-36-1095	Spindle Spacer	(1)
30	45-88-7990	Thrust Washer	(1)

FIG.	PART NO.	DESCRIPTION OF PART	NO. REQ.
31	49-15-0265	Side Handle Assembly	(1)
32	48-66-0070	1/4 Chuck	(1)
33	48-66-3200	Chuck Key	(1)
34	48-66-4080	Chuck Key Holder	(1)
35	22-84-0845	Fan	(1)
36	45-30-0030	Slug	(2)
37	45-30-0035	Slug	(1)
38	23-52-1610	Brush Spring	(2)
39	22-18-1310	Brush Assembly	(2)
40	06-75-2850	3/8-16 x 5-1/2 Hex Cap screw	(1)
41	42-68-0800	Side Handle Clamp	(1)
42	43-62-0845	Side Handle	(1)
43	06-54-0325	3/8-16 Square Nut	(1)

LUBRICATION (Type "Y" Grease, No. 49-08-5270)

- Place 5 gm. (.02 oz.) of grease on top of the inserted intermediate ball bearing (1) and on the intermediate pinion (22).
- After inserting all gearing, place 13 gm. (.46 oz.) of grease at the armature pinion location in the gearcase (15) and fill to the top of the intermediate gear (19). Grease must contact at least 25% of the intermediate gear teeth.

Before assembly, lightly coat all press fit areas with lightweight spindle oil.

FIG. NOTES:

- 4,20 Support the output ball bearing inside the gearcase before pressing off the spindle gear.
- 5,6 Needle bearings to be pressed flush to .010 under flush from the end which has the vendors identification.

MILWAUKEE ELECTRIC TOOL CORPORATION
 13135 W. LISBON RD., BROOKFIELD, WI 53005